



FLECK 3150 NXT/NXT2



INSTALLER MANUAL

Table of Contents

1	Generalities	7
1.1	Scope of the documentation	7
1.2	Release management	7
1.3	Manufacturer identifier, product	7
1.4	Intended use	7
1.5	Abbreviations used	7
1.6	Norms	8
1.6.1	Applicable norms	8
1.6.2	Available certificates	9
1.7	Procedure for technical support	9
1.8	Copyright	9
1.9	Limitation of liability	9
1.10	Scan & Service application	10
2	Safety	11
2.1	Safety pictograms definition	11
2.2	Serial label location	11
2.3	Hazards	11
2.3.1	Personnel	12
2.3.2	Material	12
2.4	Hygiene and sanitization	12
2.4.1	Sanitary issues	12
2.4.2	Hygiene measures	13
3	Description	14
3.1	Technical specifications	14
3.2	Performance flow rate characteristics	16
3.3	Outline drawing	16
3.4	Components description and location	17
3.4.1	With NXT controller and AC motor	17
3.4.2	With NXT controller and DC motor	18
3.4.3	With NXT2 controller and DC motor	19
3.5	System regeneration cycle	20
3.5.1	DF regeneration cycle (5-cycles operation)	20
3.5.2	UF regeneration cycle (5-cycles operation)	22
3.5.3	Filter cycle (3-cycles operation)	24
3.6	Injector block position for DF and UF configurations	26
4	System sizing	27
4.1	Recommendations	27

4.1.1	Injector/DLFC/BLFC-Valve configuration.....	27
4.2	Sizing a softener (single unit)	27
4.2.1	Parameters to be considered	27
4.2.2	Determining the required volume of resin	28
4.2.3	Resin exchange capacity and capacity of the unit	29
4.2.4	Valve configuration.....	31
4.2.5	Cycle time calculation	31
4.3	Salt amount definition	34
4.4	1800 Injector flow rates.....	34
5	Installation	37
5.1	Warnings.....	37
5.2	Safety notices for installation	37
5.3	Installation environment	38
5.3.1	General	38
5.3.2	Water	38
5.3.3	Electrical	38
5.3.4	Mechanical	39
5.4	Integration constraints.....	39
5.5	Valve connection to piping.....	40
5.5.1	Top-mounted valve installation	40
5.5.2	Side-mounted valve installation	42
5.6	Block diagram and configuration example.....	43
5.7	System types	44
5.7.1	Single valve (System #4).....	45
5.7.2	Multiple valves, parallel interlock system (System #5)	45
5.7.3	Multiple valves, parallel series regeneration system (System #6).....	46
5.7.4	Duplex alternating immediate system (System #7).....	46
5.7.5	Duplex alternating delayed system (System #8) (NXT2 only)	47
5.7.6	Multiple valves, parallel system with standby unit (System #9).....	47
5.7.7	Multiple valves, system on-demand (System #14).....	48
5.8	Electrical connections.....	52
5.8.1	NXT controller connections	53
5.8.2	NXT2 controller connections	54
5.8.3	NXT controller connections for multiple valves	55
5.8.4	NXT2 controller connections for multiple valves	56
5.9	Bypassing	57
5.10	Drain line connection	57
5.11	Overflow line connection.....	58
5.12	Brine line connection	59
6	Programming	60
6.1	NXT controller	60
6.1.1	Display.....	60

6.1.2	Commands	61
6.1.3	Setting the time of the day	61
6.1.4	Basic programming.....	61
6.1.5	Master programming mode	64
6.1.6	Diagnostic.....	78
6.1.7	Resetting the controller	80
6.2	NXT2 Controller.....	81
6.2.1	Display	81
6.2.2	Commands	83
6.2.3	Time of day menu	84
6.2.4	Basic programming.....	85
6.2.5	Master programming mode	87
6.2.6	Diagnostic.....	115
6.2.7	Resetting the controller	121
7	Commissioning	123
7.1	Water filling, draining and waterproofness inspection	123
7.1.1	Activating a single valve system (System #4).....	123
7.1.2	Activating a multiple valves system (Systems #5, #6, #7, #8, #9 and #14)	124
7.2	Sanitization	124
7.2.1	Disinfection of water softeners.....	124
7.2.2	Sodium or calcium hypochlorite	125
7.2.3	Electro chlorination.....	125
8	Operation.....	126
8.1	Display	126
8.1.1	NXT controller	126
8.1.2	NXT2 controller	126
8.1.3	LED status	128
8.2	Recommendations	128
8.3	Manual regeneration.....	128
8.3.1	Manual delayed regeneration	128
8.3.2	Immediate regeneration	129
8.3.3	To advance regeneration cycles	129
8.3.4	To stop a regeneration (NXT2 only)	129
8.4	Operation during a power failure.....	129
9	Maintenance	130
9.1	General system inspection.....	130
9.1.1	Water quality	130
9.1.2	Mechanical Checks	130
9.1.3	Regeneration test.....	131
9.2	Recommended maintenance plan	132
9.2.1	Valve used for softening.....	132
9.2.2	Valve used for filtration.....	134
9.3	Recommendations	135
9.3.1	Use original spare parts.....	135

9.3.2	Use original approved lubricants.....	135
9.3.3	Maintenance instructions	135
9.4	Cleaning and maintenance.....	135
9.4.1	First steps.....	135
9.4.2	Power head motor replacement.....	136
9.4.3	NXT to NXT2 controller upgrade.....	140
9.4.4	NXT2 controller replacement	142
9.4.5	Power head, piston and/or seal and spacer kit disassembly/replacement	143
9.4.6	Micro-switches replacement	145
9.4.7	Cams replacement	146
9.4.8	Injector throat and washer cleaning.....	147
9.4.9	BLFC cleaning	149
9.4.10	DLFC cleaning	150
9.4.11	Valve on tank assembly.....	151
10	Troubleshooting	152
10.1	Error detection	152
10.2	Programming error.....	154
10.3	Examples of error displayed	155
10.3.1	NXT controller	155
10.3.2	NXT2 controller	156
11	Spare parts and options.....	157
11.1	Valve parts list.....	157
11.2	Power head 3150 parts list.....	159
11.3	1800 injector parts list.....	161
11.4	BLFC parts list.....	162
11.5	DLFC parts list.....	164
11.6	Safety brine valves list	165
11.7	Distribution systems parts list.....	165
11.7.1	Thread 4", tank 21" to 36", TM, slots 0.2 mm	166
11.7.2	Flanged 6", tank 21" to 36", TM, slots 0.2 mm	167
11.7.3	Flanged 6", tank 42", TM, slots 0.2 mm	168
11.7.4	Threaded 4", tank 21" to 36", SM, top distribution, elbow 63 mm, external glue connection	169
11.7.5	Threaded 4", tank 21" to 36", SM, bottom distribution, elbow 63 mm, external glue connection	170
11.7.6	Threaded 4", tank 21" to 36", SM, top distribution, straight 63 mm, external glue connection	171
11.7.7	Threaded 4", tank 21" to 36", SM, bottom distribution, straight 63 mm, external glue connection.....	172
11.7.8	Flanged 6", tank 21" to 36", SM, top distribution, external flange 65 mm connection.....	173
11.7.9	Flanged 6", tank 21" to 36", SM, bottom distribution, external flange 65 mm connection	174

11.7.10	Hot water, flanged 6", tank 42" to 63", SM, top and bottom distribution, external flange 80 mm connection, slots 0.2 mm	175
11.7.11	Hot water, flanged 6", tank 21" to 36", SM, top and bottom distribution, external flange 65 mm connection, slots 0.2 mm	176
11.8	Air checks list	176
11.9	Meters parts list	177
11.9.1	Brass meters parts list	177
11.9.2	Stainless steel meters parts list.....	178
11.10	Kit meter & Meter cables list.....	178
11.10.1	Mechanical cable meter.....	178
11.10.2	Brass kit meter & Meter cables list.....	178
11.10.3	Stainless steel kit meter & Meter cables list	179
11.11	Kits.....	179
11.12	Other components list.....	180
12	Disposal.....	181

1 Generalities

1.1 Scope of the documentation

The documentation provides the necessary information for appropriate use of the product. It informs the user to ensure efficient execution of the installation, operation or maintenance procedures.

The content of this document is based on the information available at the time of publication. The original version of the document was written in English.

For safety and environmental protection reasons, the safety instructions given in this documentation must be strictly followed.

This manual is a reference and will not include every system installation situation. The person installing this equipment should have:

- training in the Fleck series, NXT/NXT2 controllers and water softener installation;
- knowledge of water conditioning and how to determine proper controller settings;
- basic plumbing skills.

This document is available in other languages on <https://www.pentairaquaeurope.com/product-finder/product-type/control-valves>.

1.2 Release management

Revision	Date	Authors	Description
A	09.12.2016	BRY/PBO	First edition.
B	28.05.2018	BRY/FIM	Address change, Bleam information and valve on tank assembly.
C	18.10.2019	BRY/FLA	NXT2 controller.

1.3 Manufacturer identifier, product

Manufacturer: Pentair International LLC
 Avenue de Sevelin 18
 1004 Lausanne
 Switzerland

Product: Fleck 3150 NXT/NXT2

1.4 Intended use

The device is intended for industry environment use only and it is purpose-built for water treatment.

1.5 Abbreviations used

Assy	Assembly
BLFC	Brine Line Flow Control
BV	Brine Valve

DF	Down Flow
DLFC	Drain Line Flow Control
HW	Hot Water
Inj	Injector
NBP	No By Pass
PH	Power Head
QC	Quick Connect
Regen	Regeneration
S&S	Seals & Spacers
SBV	Safety Brine Valve
SM	Side Mounted
TC	Time Clock
TM	Top Mounted
UF	Up Flow

1.6 Norms

1.6.1 Applicable norms

Comply with the following guidelines:

- 2006/42/EC: Machinery Directive;
- 2014/35/UE: Low Voltage Directive;
- 2014/30/UE: Electromagnetic compatibility;
- 2011/65/UE: Restriction of use of certain hazardous substances in electrical and electronic equipment (RoHS);
- UNI EN ISO9001.

Meets the following technical standards:

- EN 55014-1;
- EN 55014-2;
- EN 61000-6-1;
- EN 61000-6-2;
- EN 61000-6-3;
- EN 61000-6-4;
- EN 61010-1;
- EN 61000-3-2;
- EN 61000-3-3.

1.6.2 Available certificates

- CE; Please find beside the certifications for some of our product families. Please note that this list is not an exhaustive list of all our certifications. In case of need for more information please contact us.
- DM174;
- ACS.



1.7 Procedure for technical support

- ✓ Procedure to follow for any technical support request:
 - a) Collect the required information for a technical assistance request.
 - ⇒ Product identification (see Serial label location [▶Page 11] and Recommendations [▶Page 135]);
 - ⇒ Description of the device problem.
 - b) Please refer to the Troubleshooting [▶Page 152]. If the problem persists contact your supplier.

1.8 Copyright

© 2019 Pentair International Sàrl. All rights reserved.

1.9 Limitation of liability

Pentair Quality System EMEA products benefit, under specific conditions, from a manufacturer warranty that may be invoked by Pentair's direct customers. Users should contact the vendor of this product for applicable conditions and in case of a potential warranty claim.

Any warranty provided by Pentair regarding the product will become invalid in case of:



- improper installation, improper programming, improper use, improper operation and/or maintenance leading to any kind of product damages;
- improper or unauthorized intervention on the controller or components;
- incorrect, improper or wrong connection/assembly of systems or products with this product and vice versa;
- use of a non-compatible lubricant, grease or chemicals of any type and not listed by the manufacturer as compatible for the product;
- failure due to wrong configuration and/or sizing.

Pentair accepts no liability for equipment installed by the user upstream or downstream of Pentair products, as well as for process/production processes which are installed and connected around or even related to the installation. Disturbances, failures, direct or indirect damages that are caused by such equipment or processes are also excluded from the warranty. Pentair shall not accept any liability for any loss or damage to profits, revenues, use, production, or contracts, or for any indirect, special or consequential loss or damage whatsoever. Please refer to the Pentair List Price for more information about terms and conditions applicable to this product.

1.10 Scan & Service application

Scan & Service mobile application is the ideal support for the maintenance person in his daily business. A simple scan of an identification (ID) label (1) present on the valve with a smartphone gives an instantaneously access to all updated information related to the product, such as:

- valve's and tanks detailed configuration;
- manuals;
- spare parts lists;
- troubleshooting recommendations;
- multi-lingual videos, detailing how to best service a part;
- informations about new products, latest technologies, novelties about the Blue Network program, etc.

- Download the application "Scan & Service" from  or  in a smartphone (4).
- Open the application "Scan & Service".
- Scan the bleam (3) stuck on the valve (2).
- Navigate to find information.

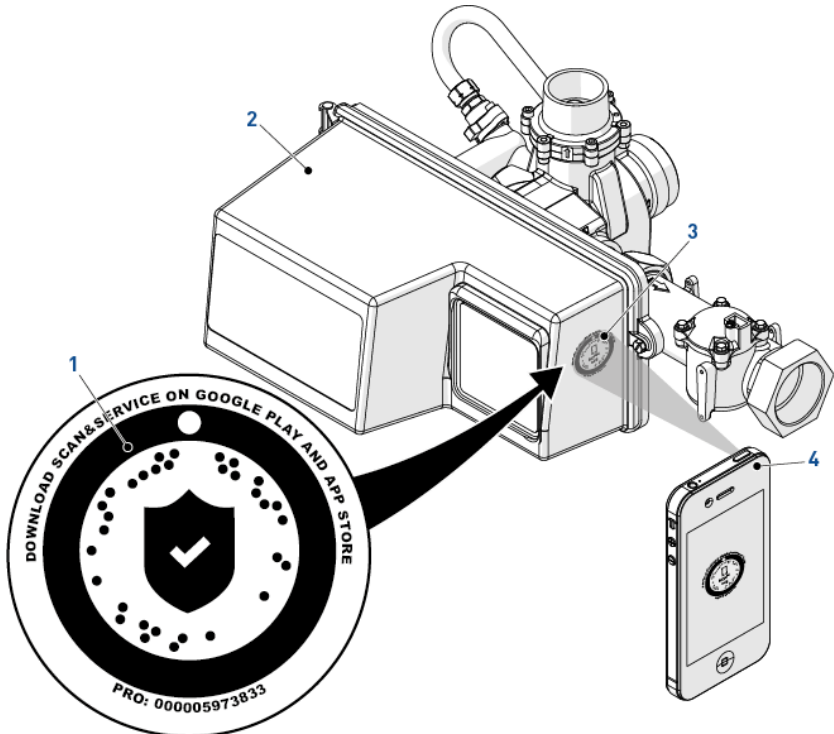

2 Safety

2.1 Safety pictograms definition



CAUTION

Warns of a risk of minor injury or major material damage to the device or environment.



WARNING

Warns against serious personal injury and damage to health.



DANGER

Warns against serious personal injury or death.



Mandatory

Standard or measure to apply.



Info

Comment.



Prohibition

Restriction to be observed.

2.2 Serial label location

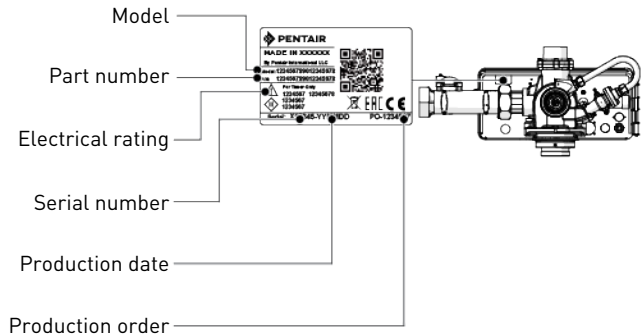

Info

Ensure that the serial label and the safety labels on the device are completely legible and clean. If necessary, replace them with new labels in the same positions.

2.3 Hazards

All the safety and protection instructions contained in this document must be observed in order to avoid temporary or permanent injury, damage to property or environmental pollution.

At the same time, any other legal regulations, accident prevention and environmental protection measures, as well as any recognized technical regulations relating to appropriate and risk-free methods of working which apply in the country and place of use of the device must be adhered to.

Any non-observation of the safety and protection rules, as well as any existing legal and technical regulations, will result in a risk of temporary or permanent injury, damage to property or environmental pollution.

2.3.1 Personnel



CAUTION

Only qualified and professional personnel, based on their training, experience and instruction as well as their knowledge of the regulations, safety rules and operations performed, are authorized to carry out necessary work.

2.3.2 Material

The following points must be observed to ensure proper operation of the system and the safety of user:

- be careful of high voltages present on the transformer (100 - 240V);
- do not put your fingers in the system (risk of injuries with moving parts and shock due to electric voltage).

2.4 Hygiene and sanitization

2.4.1 Sanitary issues

Preliminary checks and storage

- Check the integrity of the packaging. Check that there is no damage and no signs of contact with liquid to make sure that no external contamination occurred;
- the packaging has a protective function and must be removed just before installation. For transportation and storage, appropriate measures should be adopted to prevent the contamination of materials or the objects themselves.

Assembly

- Assemble only with components which are in accordance with drinking water standards;
- after installation and before use, perform one or more manual regenerations in order to clean the media bed. During such operations, do not use the water for human consumption. Perform a disinfection of the system in the case of installations for treatment of drinking water for human use.



Info

This operation must be repeated in the case of ordinary and extraordinary maintenance. It should also be repeated whenever the system remains idle for a significant time.



Info

Valid only for Italy: In case of equipment used in accordance with the DM25, apply all the signs and obligations arising from the DM25.

2.4.2 Hygiene measures

Disinfection

- The materials used for the construction of our products meet the standards for use with potable water; the manufacturing processes are also geared to preserving these criteria. However, the process of production, distribution, assembly and installation, may create conditions of bacterial proliferation, which may lead to odor problems and water contamination;
- it is therefore strongly recommended to sanitize the products. See Sanitization [[▶ Page 124](#)] ;
- maximum cleanliness is recommended during the assembly and installation;
- for disinfection, use Sodium or Calcium Hypochlorite and perform a manual regeneration.

3 Description

3.1 Technical specifications

Design specifications/ratings

Valve body	Brass
Rubber components	EP or EPDM
Weight (valve with controller)	22.8 kg (max)
Recommended operating pressure	1.8 - 8.6 bar
Maximum inlet pressure	8.6 bar
Hydrostatic test pressure	20 bar
Water temperature std	1 - 43°C
Water temperature for HW volumetric	1 - 65°C
Water temperature for HW time clock	1 - 82°C
Ambient temperature	5 - 40°C
Regeneration flow	DF or UF
Bypass of raw water during regeneration:	
Standard	Yes
NBP version	No

Flow rates (3.5 bar inlet - 16°C - valve only)

Continuous service flow ($\Delta p = 1$ bar)	Top Mount 22.0 m ³ /h; Side Mount 23.0 m ³ /h
Peak service flow ($\Delta p = 1.8$ bar)	Top Mount 28.0 m ³ /h; Side Mount 29.0 m ³ /h
Cv*	24.8
Kv*	21.5
Maximum backwash flow ($\Delta p = 1.8$ bar)	Top Mount 24.0 m ³ /h; Side Mount 25.0 m ³ /h

*Cv: Flow rate in gpm across the valve at a pressure drop of 1 psi at 60°F.

*Kv: Flow rate in m³/h across the valve at a pressure drop of 1 bar at 16°C.

Valve connections

Tank adapter thread	4" – 8 UN thread
Side mount adapter	2" BSP female
Inlet/Outlet	2" BSP female
Distributor pilot	63 mm [DN50]
Drain line	2" BSP
Brine line (1800)	1" NPT male

Electrical

Controller operating voltage	24 VAC for NXT / 24 VDC for NXT2
Input supply frequency	50 or 60 Hz (controller configuration dependent)
Transformer voltage	24 VAC for NXT / 24 VDC for NXT2
Motor input voltage until March 2019	24 VAC
Motor input voltage April 2019 onwards	24 VDC with AC-DC inverter
Controller power consumption	60 W
Controller protection rating	IP 22
Valve protection rating	IP 44
Power supply	230 VAC, 50/60 Hz, 60 VA, Class II
Transient overvoltages	within the limits of category II
Pollution Degree	3

Temporary overvoltages must be limited in duration and in frequency.

Model without transformer



CAUTION

A switch or circuit-breaker must be included in the installation, it must be suitably located and easily reached, it must be marked as the disconnecting device for the equipment.



CAUTION

The power must be achieved by a transformer in which the primary windings are separated from the secondary windings by REINFORCED INSULATION, DOUBLE INSULATION, or a screen connected to the PROTECTIVE CONDUCTOR TERMINAL.



CAUTION

It is required the installation of a fuse as overcurrent protection, it has to be positioned between the system and the secondary of the transformer in the installation with the following characteristics: $V \geq 30$ VDC or VAC, $I_{max} = 5.0A$ (ES. 5x20 5.0A)

Environmental conditions

- Indoor use only;
- temperature from 5°C to 40°C;
- maximum relative humidity 80% for temperatures up to 31°C decreasing linearly to 50% relative humidity at 40°C;
- mains supply voltage fluctuations up to $\pm 10\%$ of the nominal voltage.

3.2 Performance flow rate characteristics

The graph shows the pressure drop created by the valve itself at different flow rates. It allows predetermining the maximum flow rate going through the valve depending on the system settings (inlet pressure etc). It also allows to determine the valve pressure drop at a given flow rate, and therefore to evaluate the system pressure drop vs flow rate.

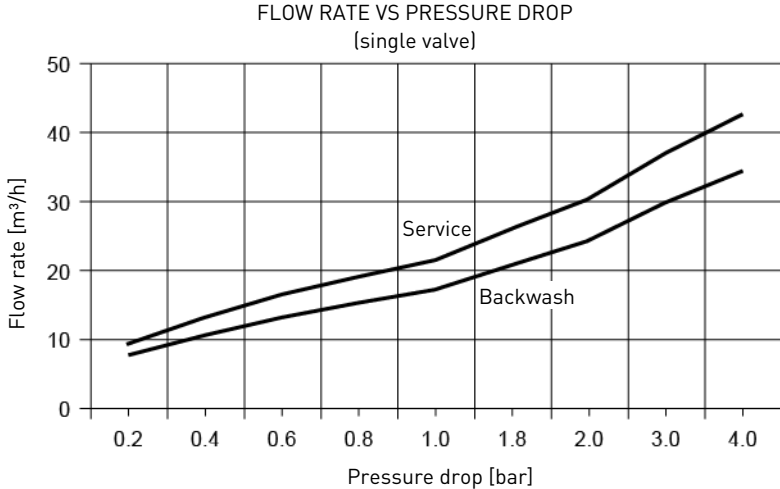

3.3 Outline drawing

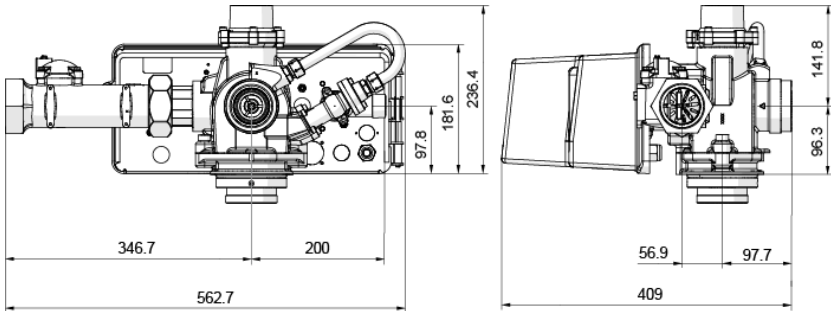

3.4 Components description and location

3.4.1 With NXT controller and AC motor

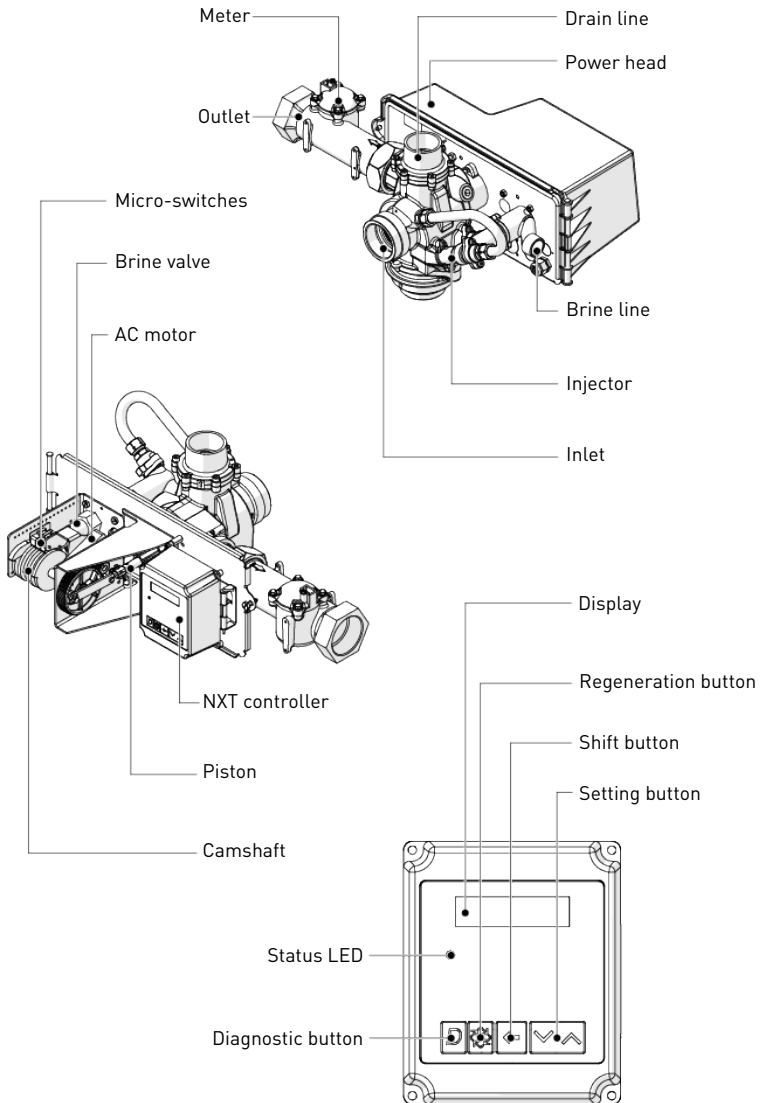

3.4.2 With NXT controller and DC motor



Info

As of April 2019, NXT valves are supplied with 24 VDC motor. This motor is equipped with an AC-DC converter allowing it to be powered with 24 VAC or 24 VDC. Therefore, when used with NXT boards which require 24 VAC power supply and therefore send 24 VAC to the motor, the inverter will convert it into 24 VDC.

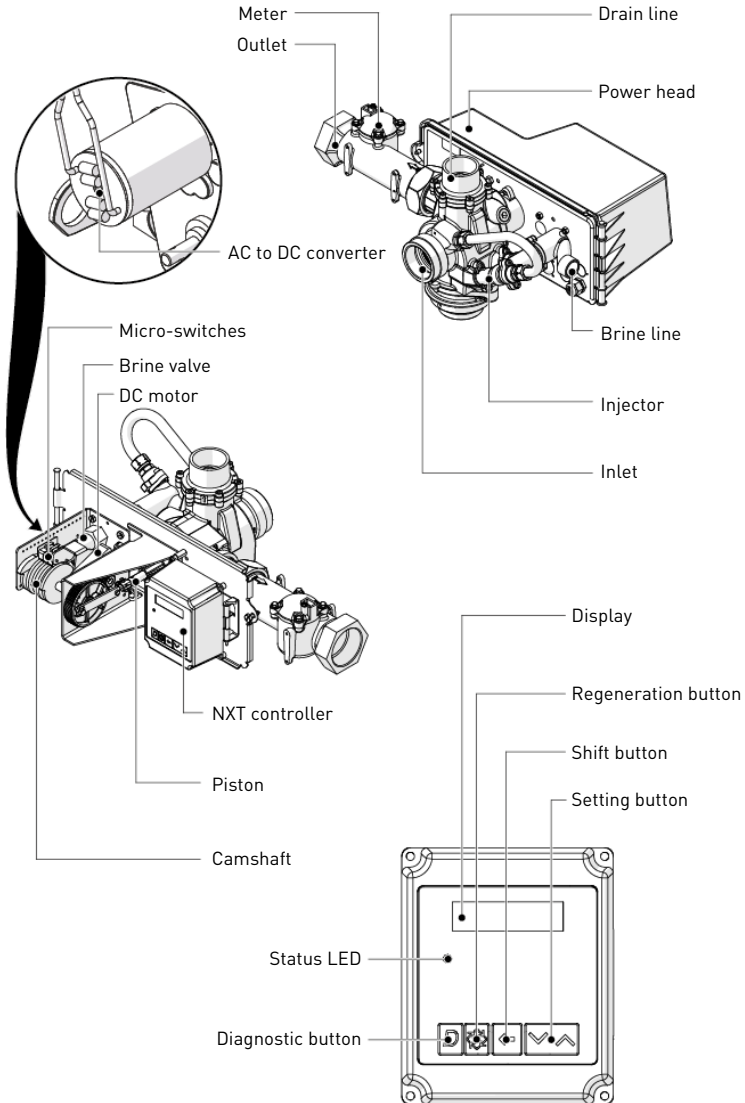

3.4.3 With NXT2 controller and DC motor

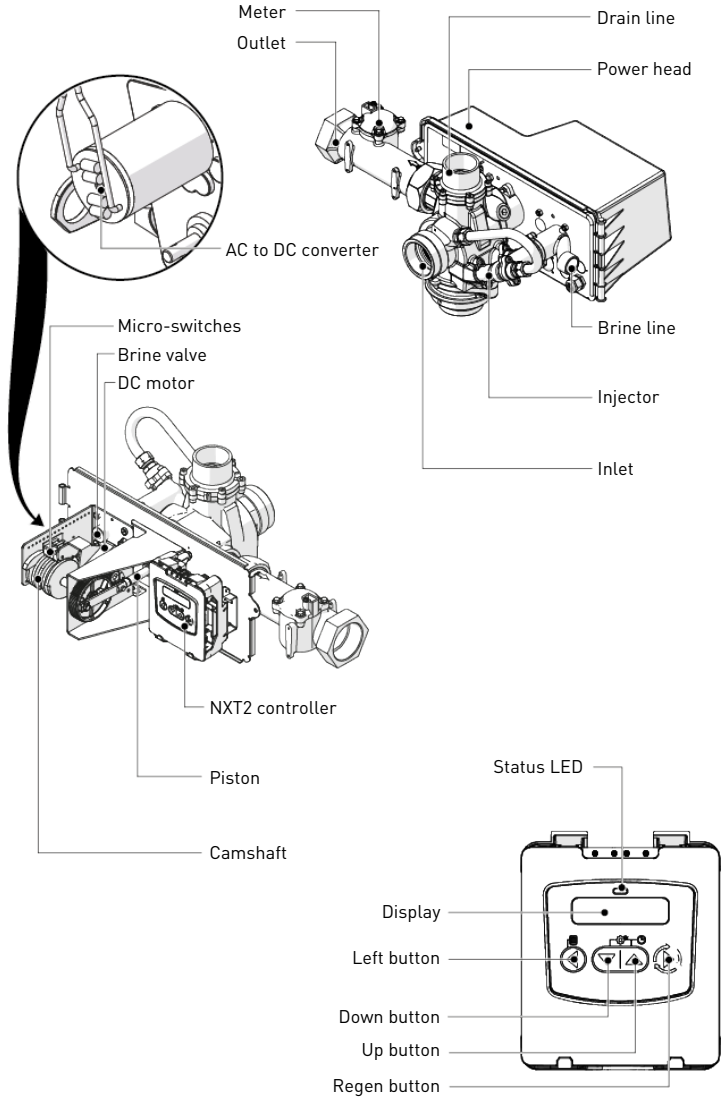

3.5 System regeneration cycle



Info

This valve allows to do filtration, down flow and up flow regenerations.

3.5.1 DF regeneration cycle (5-cycles operation)

Service — normal use

Untreated water is directed down through the resin bed and up through the riser tube. The hardness ions attach themselves to the resin and are removed from the raw water being exchanged on the resin beads by sodium ions. The water is conditioned as it passes through the resin bed.

Backwash — cycle C1

The flow of water is reversed by the valve and directed down the riser tube and up through the resin bed. During the backwash cycle, the bed is expanded and debris is flushed to the drain, while the media bed is remixed.

Brine draw & slow rinse — cycles C2

The valve directs water through the brine injector and brine is drawn from the brine tank. The brine is then directed down through the resin bed and up through the riser tube to the drain. The hardness ions on the resin beads are replaced by sodium ions and are sent to the drain. The resin is regenerated during the brine cycle. When the air check valve closes brine drawing finishes, and then the slow rinse phase starts.

Rapid rinse — cycle C3

The valve directs water down through the resin bed and up through the riser tube to the drain. Any residual brine is rinsed from the resin bed, while the media bed is re-compacted.

Brine tank refill — cycle C4

Water is directed to the brine tank, at a rate controlled by the refill controller, to create brine for the next regeneration. During brine refill, treated water is already available at the valve outlet.

Pause & Delay — cycle C5

The valve is in stand-by until the end of the cycle. In multiplex, if the brine tank is shared, allows to leave a brine preparation time.



Info

The cycle Pause & Delay is optional with NXT controller. The factory value is set to 0 minute.



Info

For illustration purpose only. Always verify inlet and outlet marking on the valve.

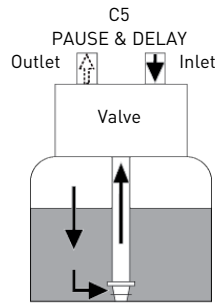
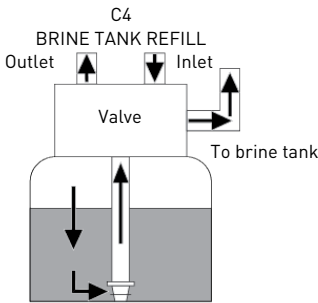
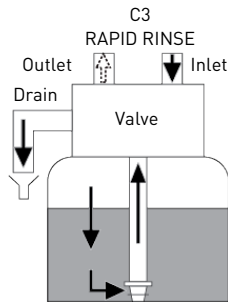
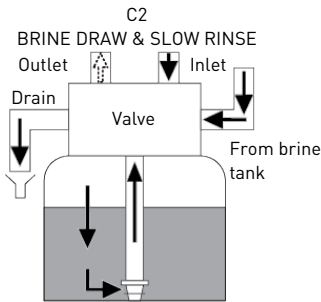
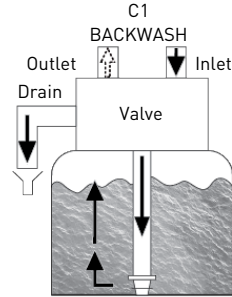
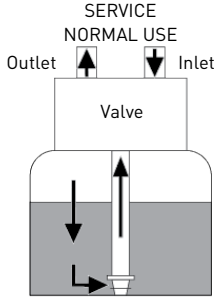

☞ Untreated water, with WBP piston only

3.5.2 UF regeneration cycle (5-cycles operation)

Service — normal use

Untreated water is directed down through the resin bed and up through the riser tube. The hardness ions attach themselves to the resin and are removed from the raw water being exchanged on the resin beads by sodium ions. The water is conditioned as it passes through the resin bed.

Pause & Delay — cycle C1

The valve is in stand-by until the end of the cycle. In multiplex, if the brine tank is shared, allows to leave a brine preparation time.



Info

The cycle Pause & Delay is optional with NXT controller. The factory value is set to 0 minute.

Brine draw & slow rinse — cycles C2

The valve directs water through the brine injector and brine is drawn from the brine tank. The brine is then directed down through the riser tube and up through the resin bed to the drain. The hardness ions are replaced by sodium ions and are sent to the drain. The resin is regenerated during the brine cycle. Then the slow rinse phase starts.

Backwash — cycle C3

The flow of water is reversed by the valve and directed down the riser tube and up through the resin bed. During the backwash cycle, the bed is expanded and debris is flushed to the drain, while the media bed is remixed.

Rapid rinse — cycle C4

The valve directs water down through the resin bed and up through the riser tube to the drain. Any residual brine is rinsed from the resin bed, while the media bed is re-compacted.

Brine tank refill — cycle C5

Water is directed to the brine tank, at a rate controlled by the refill controller, to create brine for the next regeneration. During brine refill, treated water is already available at the valve outlet.



Info

For illustration purpose only. Always verify inlet and outlet marking on the valve.

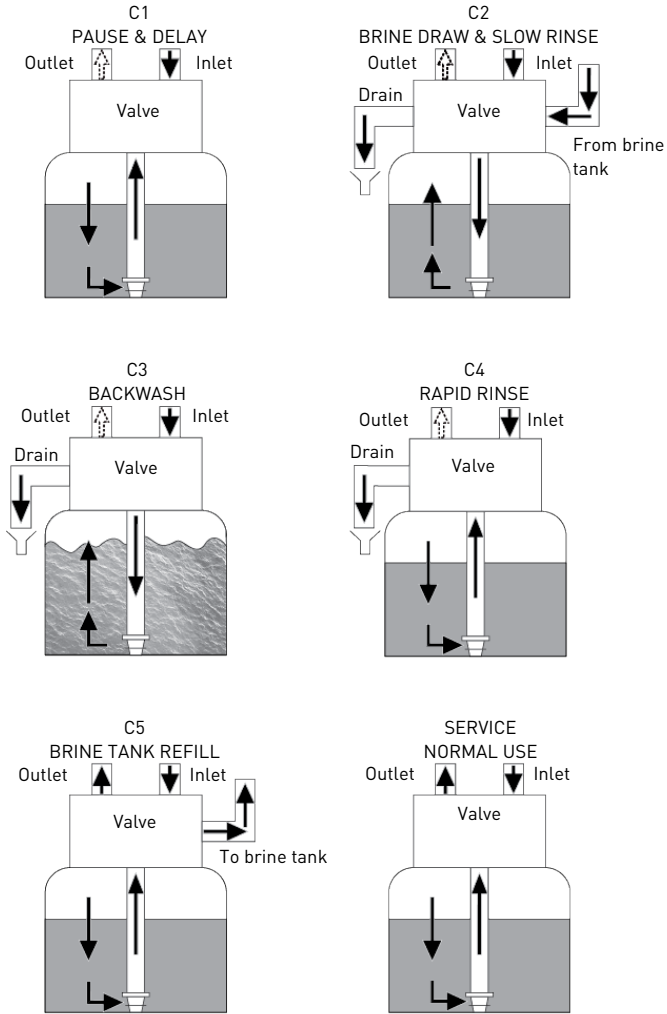

➡ Untreated water, with WBP piston only

3.5.3 Filter cycle (3-cycles operation)

Service — normal use

Untreated water is directed down through the filter media and up through the riser tube. The impurities are retained by the media. The water is filtered as it passes through the media.

Backwash — cycle C1 for DF configuration, C2 for UF configuration

The flow of water is reversed by the valve and directed down through the riser tube and up through the filter media. During the backwash cycle, the filter bed is expanded and debris is flushed to the drain, while the media bed is remixed.

Rapid rinse — cycle C3 for DF configuration, C4 for UF configuration

The valve directs water down through the filter media and up through the riser tube to the drain. The media bed is getting re-compacted.



Info

For illustration purpose only. Always verify inlet and outlet marking on the valve.

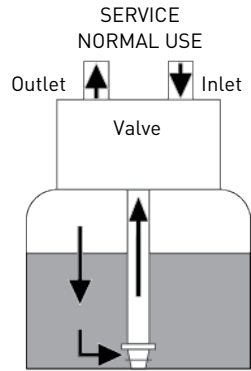
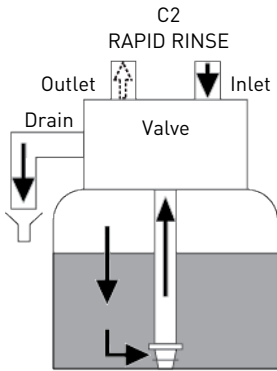
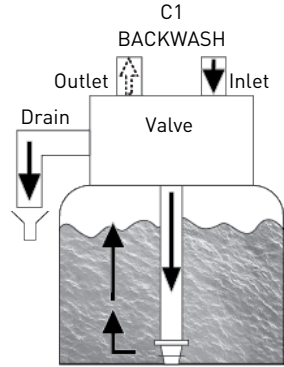
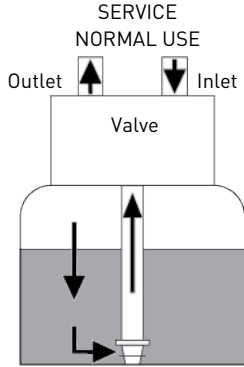

➡ Untreated water, with WBP piston only

3.6 Injector block position for DF and UF configurations

DF

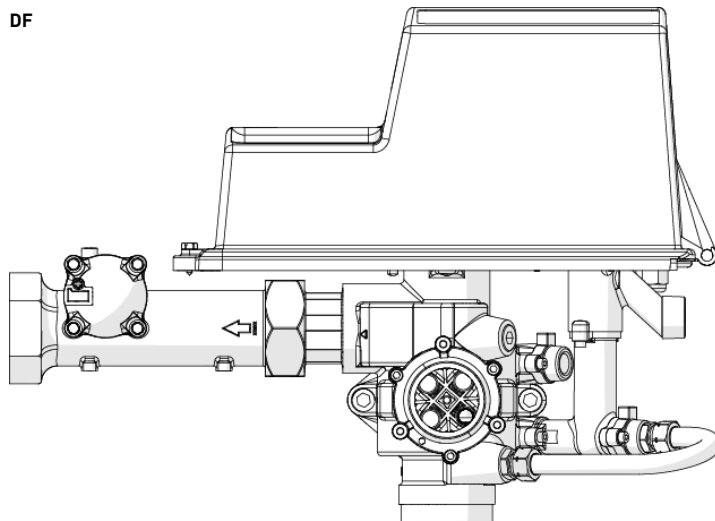

UF

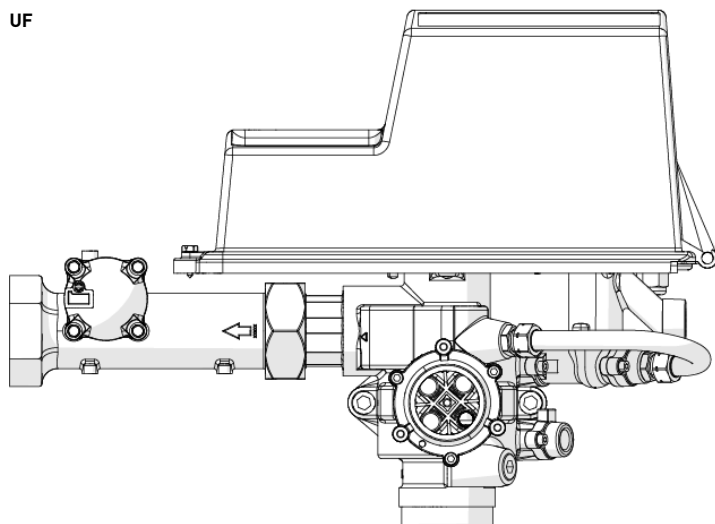

4 System sizing

4.1 Recommendations

4.1.1 Injector/DLFC/BLFC-Valve configuration

Brine syst.	Tank Diameter	Resin volume	Injector				DLFC	BLFC	
	[in]	L	DF	Color	UF	Color	[gpm]	DF [gpm]	UF [gpm]
3150/ 1800	24	283 - 424	4	Green	4	Green	20.0	5.0	5.0
	30	284 - 425	5	Red		25.0			
	36	426 - 605	6	White	5	Red	35.0		
	42	566 - 850	7	Blue	6	White	50.0	10.0	10.0
	48	851 - 1200	8	Yellow	7	Blue	70.0		
	54	1201 - 1550	9	Purple	8	Yellow	80.0		
	60	1551 - 2000	10	Black			100.0		

4.2 Sizing a softener (single unit)

4.2.1 Parameters to be considered

Whenever installing a softener, it is preferable to have full water analysis to ensure the inlet water content will not affect the resin bed.



Info

Please consult your resin manufacturer specifications to ensure that no additional pretreatment prior to softening is required.

The below sizing method can be applied for both residential and industrial softeners.

The sizing of a softener must be based upon certain parameters:

- inlet water hardness;
- peak flow rate and nominal flow rate;
- service velocity;
- salt dosage.

The softening and regeneration reactions are driven under certain conditions. To allow these reactions to take place, make sure that the velocity is convenient during the different phases for proper ion exchange. This velocity is given in the resin manufacturer specifications sheet.

Depending on the inlet water hardness, the service velocity for standard softening must be between:

Service velocity [bed volume per hour]	Inlet water hardness [mg/l as CaCO ₃]	°f °TH	°dH
8 - 40	<350	<35	<19.6
8 - 30	350 to 450	35 - 45	19.6 - 25.2
8 - 20	>450	>45	>25.2



Info

Failure to respect the service velocity will lead to hardness leakage or even total softener inefficiency.

Note that the water supply piping size may also be useful when estimating the nominal flow rate, since the size of the piping allows a maximum flow rate to pass. Assuming the maximum velocity of water in pipes is about 3 m/s, a good estimation for most common pressure [3 bar] and temperature [16°C] is:

Piping size (internal diameter)		Max. flow rate
[in]	[mm]	[m ³ /h at 3 m/s]
0.5	12	1.22
0.75	20	3.39
1	25	5.73
1.25	32	8.69
1.5	40	13.57
2.0	50	21.20
2.5	63	34.2
3.0	75	49.2

4.2.2 Determining the required volume of resin

When sizing a softener, make sure that the volume of resin in the tank (bed volume) will be sufficient so that even when the peak flow rate is reached, the velocity is still between the above values depending on the hardness. When sizing a softener, always choose the resin volume and tank size based on the peak flow rate but not on the nominal flow rate.



Info

Sizing on the nominal flow rate without taking the peak flow rate into account would result in choosing smaller tank size and resin volume, and may lead in severe hardness leakage during the service cycle when the peak flow is reached.

The maximum softened water flow rate that a softener can produce is given by the following formula:

$$Q_{\text{service max}} = F_{\text{service}} \times BV$$

with:

$Q_{\text{service max}}$: service flow rate [m^3/h]

F_{service} : service velocity [BV/h]

BV: bed volume of resin [m^3]

Knowing this required volume of resin, it is possible now to determine the needed tank. Note that at least a third of the total volume of the tank must be kept as free space so that the bed expansion during backwash is sufficient to ensure correct cleaning of the resin.

4.2.3 Resin exchange capacity and capacity of the unit

The resin exchange capacity and capacity of the unit are two different things that should not be confused. The resin exchange capacity is the amount of Ca^{2+} and Mg^{2+} that can be retained by 1 liter of resin, which will depend on the resin type and salt dosage, whereas the capacity of the unit is the capacity of the system, which will depend on the volume of resin and resin exchange capacity.

Knowing the required volume of resin, it is possible to determine the exchange capacity of the unit. The capacity of the unit can be expressed in different ways:

- the mass capacity, which corresponds to the weight in equivalent CaCO_3 that can be fixed on the resin, expressed in kg as CaCO_3 ;
- the volume capacity, which represents the maximum amount of water that can be treated between 2 regenerations. This last capacity takes into account the hardness of the water to be treated and is expressed in m^3 or liter;
- the combined capacity, which represents the volume of water that could be treated between 2 regenerations if the inlet hardness is 1 °f or °dH. This capacity is expressed in °f.m³ or °dH.m³.

The resin exchange capacity will depend on the amount of salt to be injected into the resin bed during the regeneration. This amount of salt is given in grams per liter of resin. The next table is showing the resin exchange capacity in function of the amount of salt for a system with standard efficiency regeneration.

Resin exchange capacity as a function of the salt dosage:

Salt amount [g/L _{resin}]	Corresponding resin exchange capacity in [g/ L _{resin}] as CaCO_3	°f.m ³ [per L _{resin}]	°dH.m ³ [per L _{resin}]
50	29.9	2.99	1.67
60	34	3.4	1.9
70	37.5	3.75	2.09
80	40.6	4.06	2.27
90	43.4	4.34	2.42
100	45.9	4.59	2.56
110	48.2	4.82	2.69
120	50.2	5.02	2.8
130	52.1	5.21	2.91

140	53.8	5.38	3.01
150	55.5	5.55	3.1
170	58.5	5.85	3.27
200	62.7	6.27	3.5
230	66.9	6.69	3.74
260	71	7.1	3.97
290	75.3	7.53	4.21

To calculate the system mass capacity:

$$M_{\text{capacity}} = V_{\text{resin}} \times C_{\text{resin ex}}$$

with:

M_{capacity} : system mass capacity [g as CaCO_3]

V_{resin} : volume of resin [L]

$C_{\text{resin ex}}$: resin exchange capacity [g/L_{resin} as CaCO_3]

To calculate the system combined capacity:

$$C_{\text{capacity}} = V_{\text{resin}} \times C_{\text{cor resin ex}}$$

with:

C_{capacity} : system combined capacity [$^{\circ}\text{f.m}^3$ or $^{\circ}\text{dH.m}^3$]

V_{resin} : volume of resin [L]

$C_{\text{cor resin ex}}$: corresponding resin exchange capacity [$^{\circ}\text{f.m}^3/\text{l}$ or $^{\circ}\text{dH.m}^3/\text{l}$]

To calculate the system volume capacity:

$$V_{\text{capacity}} = M_{\text{capacity}} / \text{TH}_{\text{inlet}}$$

with:

V_{capacity} : system volume capacity [m^3]

Or

M_{capacity} : system mass capacity [g as CaCO_3]

C_{capacity} : system combined capacity [$^{\circ}\text{f.m}^3$ or $^{\circ}\text{dH.m}^3$]

$$V_{\text{capacity}} = C_{\text{capacity}} / \text{TH}_{\text{inlet}}$$

TH_{inlet} : inlet water hardness [mg/L as CaCO_3 or $^{\circ}\text{f}$ or $^{\circ}\text{dH}$]



CAUTION

If a mixing device is set on the valve before meter, $\text{TH} = \text{TH}_{\text{INLET}} - \text{TH}_{\text{OUTLET}}$.

Having determined the previous capacity allows the operator to know the service cycle duration.

4.2.4 Valve configuration

Knowing the volume of resin, tank size and specifications of the resin, it is possible to determine the required valve configuration. The resin specification will give the backwash velocity, as well as the brine draw and slow rinse velocity that must be respected in order to ensure a proper regeneration of the unit. From this data, determine the required backwash flow rate as well as the brine draw and slow rinse flow rate. In most cases, the fast rinse flow rate will be the same as the backwash flow rate, however for certain valve types the fast rinse flow rate will be the same as the service flow rate.

To determine the backwash flow rate:

$$Q_{\text{backwash}} = F_{\text{S}_{\text{backwash}}} \times S$$

with:

Q_{backwash} : backwash flow rate [m³/h]

$F_{\text{S}_{\text{backwash}}}$: backwash velocity [m/h]

S: Tank cross section area [m²]

The DLFC installed on the valve has to limit the backwash flow rate to the above calculated flow rate.

To determine the injector size:

The velocities to be respected for brine draw and slow rinse are given on the resin manufacturer specifications. Generally speaking, the injector has to allow a flow rate of about 4BV / h (corresponding to the flow rate of brine being drawn added to the flow rate of raw water passing through the injector nozzle to create the suction effect).

$$Q_{\text{inj}} = 4 \times \text{BV} / \text{h}$$

with:

Q_{inj} : total flow rate passing through the injector [L/h]

BV: bed volume of resin [L]



Info

This value does not correspond to the brine draw flow rate but to the total flow rate passing through the injector. Then refer to the injector diagrams at the inlet pressure in order to check if the injector will give a correct flow rate. See chapters Salt amount definition [► Page 34] and 1800 Injector flow rates [► Page 34].

4.2.5 Cycle time calculation

From this point, the volume of resin, the tank size, the capacity of the softener and the valve configuration are determined. Next step is to calculate the regeneration cycle duration, which depends on the valve configuration and once again on the resin specifications.



Info

Preprogrammed cycle times are only factory default programming that need to be adjusted to fit the system requirements.

For cycle time calculation the valve configuration must be known, which depends on:

- the tank size;
- the resin specifications for the velocity for backwashing the resin bed;
- the velocity of water for brine draw, slow rinse and fast rinse.

Further information needed for cycle time calculation are:

- the resin volume previously determined;
- the salt amount used per regeneration;
- the volume of water to use for backwash, brine draw, slow rinse and fast rinse.

To calculate the backwash duration:

$$T_{\text{backwash}} = (N_{\text{BVbw}} \times \text{BV}) / Q_{\text{DLFC}}$$

with:

T_{backwash} : backwash duration [min]

N_{BVbw} : number of bed volume for backwash

BV: bed volume [L]

Q_{DLFC} : drain line flow controller size [L/min]



Info

The typical value of the volume of water to be used for backwash is between 1.5 and 4 times the bed volume, depending on the inlet water quality.

To calculate the brine draw duration:

Knowing the injector draw flow rate at the working pressure:

$$T_{\text{brine draw}} = V_{\text{brine}} / Q_{\text{draw}}$$

with:

$T_{\text{brine draw}}$: brine draw duration [min]

V_{brine} : brine volume to be drawn [L], see Refill calculation

Q_{draw} : injection draw flow rate [L/min]



Info

Multiply the amount of salt in kg by 3 to get a approximation of the brine volume to draw.

To calculate slow rinse duration:

The volume of water to be used for slow rinse is given in the resin manufacturers specifications. Generally speaking, it is advised that between 2 and 4 BV of water is used to perform the slow rinse after brine draw. The slow rinse cycle allows brine to be pushed slowly through the resin bed, allowing the resin to be in contact with brine for sufficient time and therefore to be regenerated.

Refer to the injector curve at the common working pressure to determine the slow rinse duration.

$$T_{\text{slow rinse}} = (N_{\text{BVsr}} \times \text{BV}) / Q_{\text{SR}}$$

with:

$T_{\text{slow rinse}}$: slow rinse duration [min]

N_{BVsr} : number of bed volume for slow rinse

BV: bed volume [L]

Q_{SR} : injector slow rinse flow rate [L/min]

To calculate fast rinse duration:

The fast rinse is aimed at eliminating an excess of salt in the resin bed and also recompacting the resin in the tank.

Depending on the valve type, the fast rinse flow rate is controlled by the DLFC or it has about the same flow rate as in service. The fast rinse velocity can be the same as the service velocity, and the volume of water to be used for the fast rinse is generally between 1 and 10 BV depending on the salt dosage.

$$T_{\text{fast rinse}} = (N_{\text{BVfr}} \times \text{BV}) / Q_{\text{DLFC}}$$

with:

$T_{\text{fast rinse}}$: fast rinse duration [min]

N_{BVfr} : number of bed volume for fast rinse

BV: bed volume [L]

Q_{DLFC} : drain line flow controller size [L/min]

To calculate the refill duration:

The refill flow rate is controlled by the refill controller (BLFC). The relation between the BLFC size, the tank size and the resin volume is given in the valve specifications.

To calculate the refill duration:

$$T_{\text{refill}} = V_{\text{WB}} / Q_{\text{BLFC}}$$

with:

T_{refill} : refill duration [min]

V_{WB} : Volume of water to be refill to prepare the brine [L]

Q_{BLFC} : BLFC size [L/min]

$$V_{WB} = D_{Salt} \times BV / S_{sol}$$

with:

V_{WB} : Volume of water to be refill to prepare the brine [L]

D_{Salt} : Salt dosage per liter of resin [g/L]

BV: Bed volume [L]

S_{sol} : 360g/L - Solubility of salt per liter of water



Info

When calculating the time required to draw the brine, take into account that the volume of brine [V_{brine}] will be 1.125 bigger than the volume of water refilled.

4.3 Salt amount definition

The salt settings are controlled through the controller programming. See Resin exchange capacity and capacity of the unit [► Page 29].

4.4 1800 Injector flow rates

The following tables and graphics represent the injectors flow rate as a function of the inlet pressure for the different injector sizes.

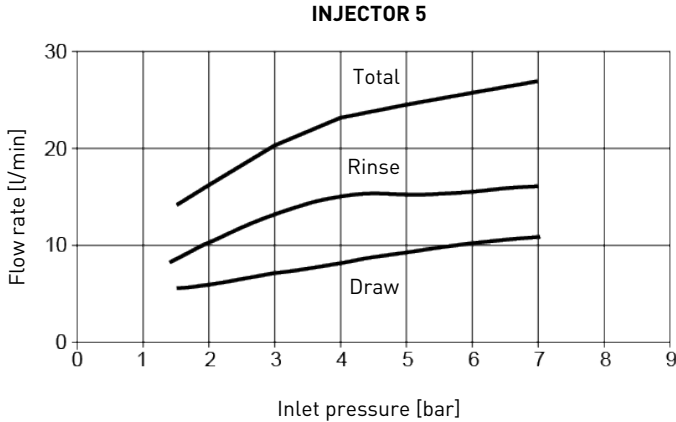

INJECTOR 6

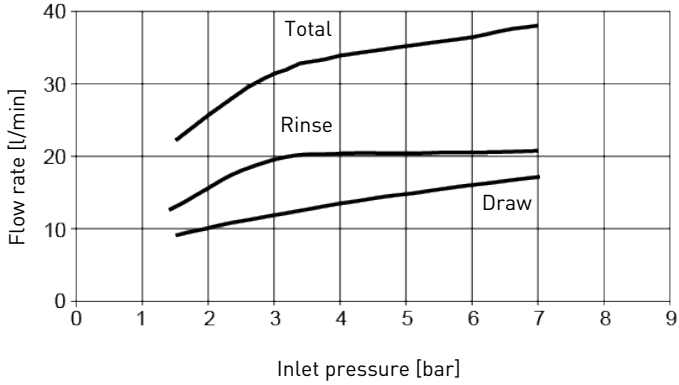

INJECTOR 7

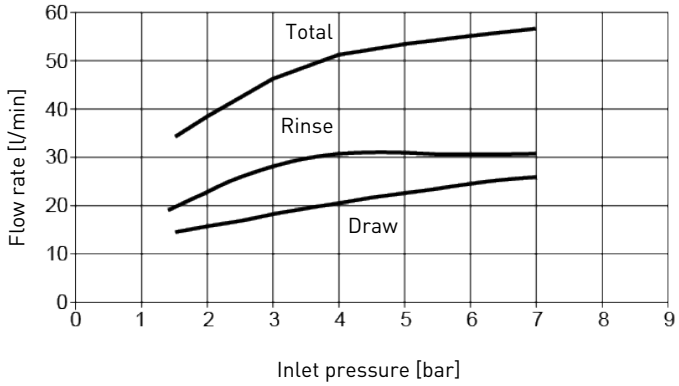

INJECTOR 8

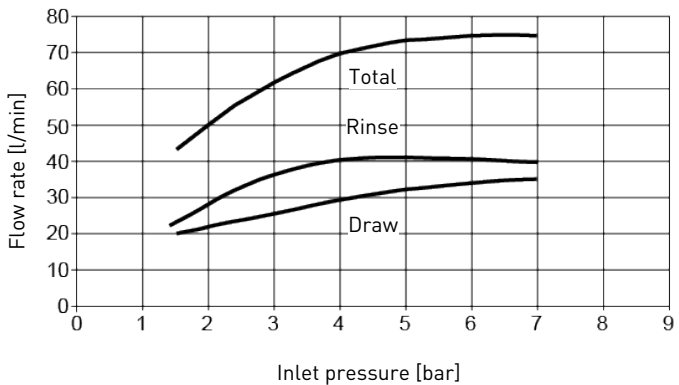

INJECTOR 9

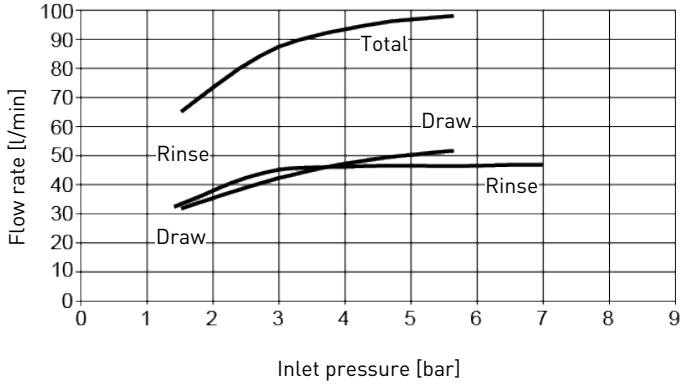

INJECTOR 10

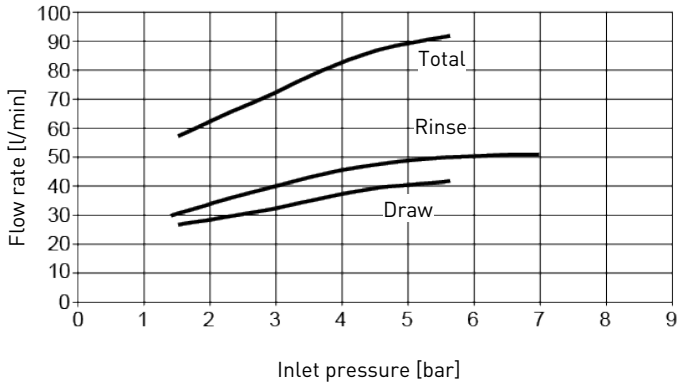

5 Installation



Mandatory

It is strictly forbidden for not qualified personal, to accede to system's internal parts to perform any kind of technical action. Be sure to disconnect the electrical power, close the water inlet and depressurize the system before opening the front cover to access internal parts.

5.1 Warnings

The manufacturer will not be held liable for any damages to people or properties resulting from an improper use of the device not compliant with the following instructions.

Whenever this guide doesn't clarify all doubts about installation, service or maintenance, please contact the technical support of the company that has installed the device.

Device installation must be done by a qualified technician according to the current standards and regulations, using tools compliant with a device for a safety use and referring to that technician also for device maintenance.

In case of out of order or malfunction, before performing any kind of action on the device, please ensure to have disconnected the transformer from the power source, to shut off inlet water supply to the valve and to drain water pressure opening a tap down-line of the valve.

1. Be careful when removing the valve from the box and during subsequent handling, weight is liable to cause damage to property and persons in case of accidental impact.
2. Before sending the water on the valve, make sure that all plumbing connections are tight and properly implemented in order to avoid dangerous leaks of pressurized water.
3. Use caution when installing welded metal piping near the valve, the heat may damage the plastic body of the valve and the bypass.
4. Be careful not to let the full weight of the valve on fittings, pipes or bypass.
5. Make sure that the environment in which the valve is installed does not reach freezing temperatures of the water, the valve may be damaged.
6. Make sure that the tank containing the resin is vertical; otherwise the resin could enter in the valve and damage it.

5.2 Safety notices for installation

- Observe all warnings that appear in this manual;
- only qualified and professional personnel are authorized to carry out installation work.

5.3 Installation environment

5.3.1 General

- Use only brine salts designed for water softening. Do not use ice melt, block, or rock salts;
- keep the media tank in an upright position. Do not turn on its side, upside down, or drop it. Turning the tank upside down may cause media to enter the valve or might clog the upper screen;
- follow state and local codes for water testing. Do not use water that is micro-biologically unsafe or of unknown quality;
- when filling the media tank, first place the valve in the backwash position, then partly open the valve. Fill the tank slowly to prevent media from exiting the tank;
- when installing the water connection (bypass or manifold), first connect to the plumbing system. Allow heated parts to cool and cemented parts to set before installing any plastic parts. Do not get primer or solvent on O-rings, nuts, or the valve.

5.3.2 Water

- Water temperature must not exceed 43°C for standard version, 65°C for volumetric hot water version and 82°C for time clock hot water version;
- a minimum of 1.8 bar of water pressure is required for the regeneration valve to operate effectively.



Mandatory

Do not exceed a maximum of 8.6 bar inlet pressure. In such cases, it is necessary to install a pressure regulator upstream the system.

5.3.3 Electrical

There are no user-serviceable parts in the AC/AC or AC/DC transformer, motor, or controller. In the event of a failure, these should be replaced.

- All electrical connections must be completed according to local codes;
- use only the power AC/AC or AC/DC transformer that is supplied;



Mandatory

The use of any other power transformer than the one supplied void the warranty of all electronic parts of the valve.

- the power outlet must be grounded;
- to disconnect power, unplug the AC/AC or AC/DC transformer from its power source;
- an uninterrupted current supply is required. Please make sure that the voltage supply is compatible with the unit before installation;

- make sure the controller power source is plugged in;
- if the electrical cable is damaged, it is imperative that it is replaced by a qualified personnel.

5.3.4 Mechanical

- Do not use petroleum-based lubricants such as vaseline, oils, or hydrocarbon-based lubricants. Use only 100% silicone lubricants;
- all plastic connections should be hand-tightened. PTFE (plumber's tape) may be used on connections that do not use an O-ring seal. Do not use pliers or pipe wrenches;
- existing plumbing should be in a good shape and free from limescale. In case of doubt, it is preferable to replace it;
- all plumbing must be completed according to local codes and installed without tension or bending stresses;
- soldering near the drain line should be done before connecting the drain line to the valve. Excessive heat will cause interior damage to the valve;
- do not use lead-based solder for sweat solder connections;
- the riser tube should be cut 0 to 3 mm below the top of the tank. Slightly bevel the ridge in order to avoid deterioration of the seal whilst fitting the valve;
- the drain line must be a minimum of 25.4 mm (1") in diameter;
- do not support the weight of the system on the valve fittings, plumbing, or the bypass;
- it is not recommended to use sealants on the threads. Use PTFE (plumber's tape) on the threads of the drain elbow, and other NPT/BSP threads;
- the installation of a pre filter is always recommended (100 μ nominal);
- valve inlet/outlet must be connected to main piping via flexible.

5.4 Integration constraints

Location of a water treatment system is important. The following conditions are required:

- flat and firm level platform or floor;
- room to access equipment for maintenance and adding brine (salt) to tank;
- constant electrical supply to operate the controller;
- total minimum pipe run to water heater of 3 m (10 ft) to prevent backup of HW into system;
- always install check valve before water heater to protect the softener from HW return;
- local drain for discharge as close as possible;
- water line connections with shut off or bypass valves;
- must meet any local and state codes for site of installation;

- valve is designed for minor plumbing misalignments. Do not support weight of system on the plumbing;
- be sure all soldered pipes are fully cooled before attaching plastic valve to the plumbing.

5.5 Valve connection to piping

The connections should be hand tightened using PTFE (plumber's tape) on the threads if using the threaded connection type.

In case of heat welding (metal type connection), the connections should not be made to the valve when soldering.



Info

See chapter Components description and location [▶ Page 17] to identify the connections.

When pressurized, any composite tank will expand both vertically and circumferential. In order to compensate the vertical expansion, the piping connections to the valve must be flexible enough to avoid overstress on the valve and tank.

5.5.1 Top-mounted valve installation

The valve and tank should not be supporting any part of the piping weight. This is hence compulsory to have the piping fixed to a rigid structure (e.g. frame, skid, wall...) so that the weight of it is not applying any stress on the valve and tank.

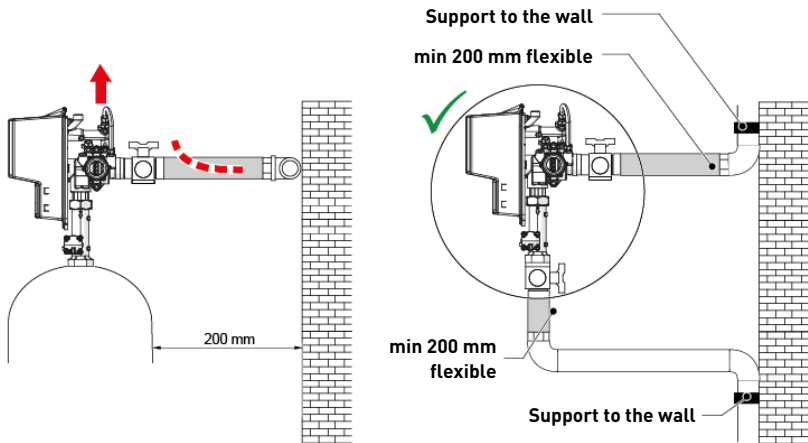

- The diagrams above illustrate how the flexible piping connection should be mounted;
- in order to adequately compensate the tank elongation the flexible tubes must be installed horizontally;

- should the flexible piping connection be installed in vertical position, instead of compensating the elongation, it will create additional stresses on the valve & tank assembly. Therefore this is to be avoided;
- the flexible piping connection must be also being installed stretched, avoiding excessive length. For instance 20 – 40 cm is enough;
- excessively long and non-stretched flexible piping connection will create stresses on the valve and tank assembly when the system is pressurized, as illustrated in the below picture: on the left the assembly when the system is unpressurized, on the right the flexible piping connection when put under pressure tends to lift up the valve when stretching up. This configuration is even more dramatic when using semi-flexible piping;
- failure to provide enough vertical compensation may lead to different kinds of damage, either on the valve thread which connect to the tank, or on the female thread connection of the tank that connect to the valve. In some cases, damage may also be seen on the valve inlet and outlet connections;

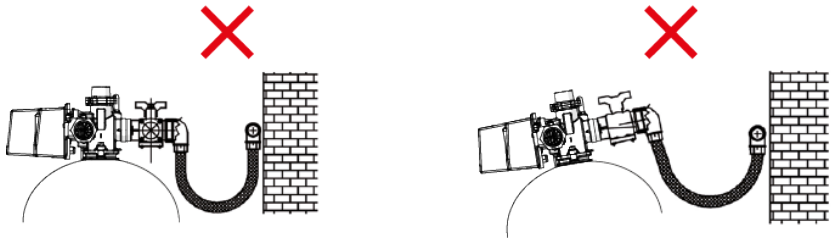

- in any case, any failure caused by improper installations and/or piping connections may void the warranty of Pentair products;
- in the same way, using lubricant* [[Page 41](#)] on the valve thread is not allowed and will void the warranty for the valve and tank. Indeed using lubricant there will cause the valve to be over-torqued, which may lead to valve thread or tank thread damage even if the connection to piping has been done following the above procedure.

*Note: Use of petroleum-based grease and mineral based lubricant is totally forbidden, not only on the valve thread, since plastics (especially Noryl) will highly suffer from contact with this type of grease, leading into structural damage hence to potential failures.

5.5.2 Side-mounted valve installation

Valid for location having a reduced height.

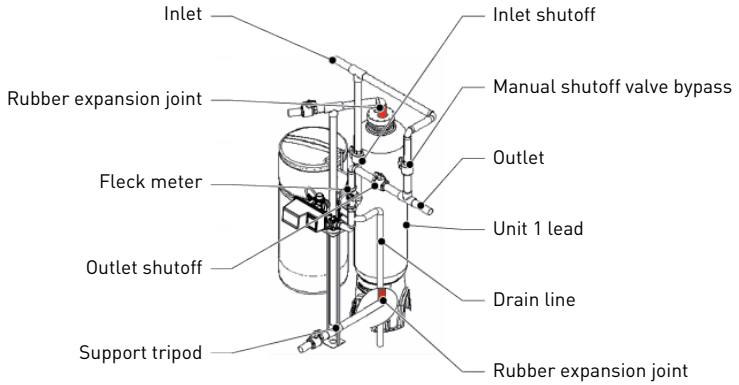

- To avoid the piping supporting the valve and side adapter weight, they must be fixed on a tripod or any other appropriate support;
- in order to adequately compensate the tank elongation, the rubber expansion joints must be mounted on the top and bottom of the tank. In red on the diagram above.

5.6 Block diagram and configuration example

Block diagram

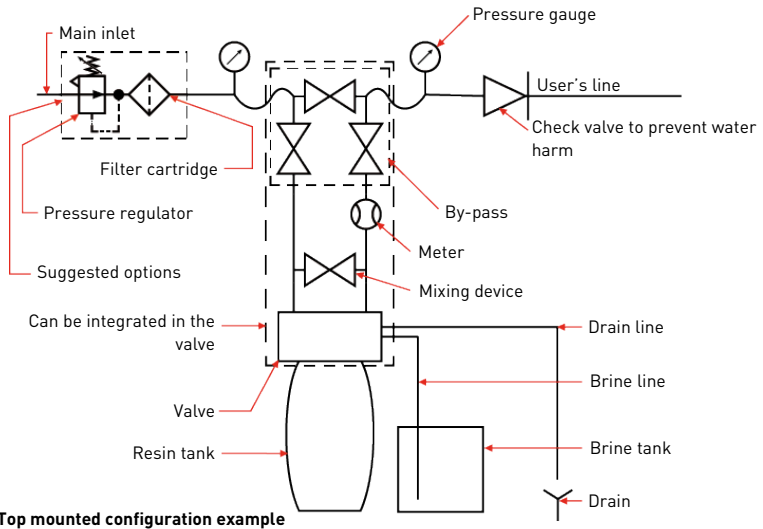

Top mounted configuration example

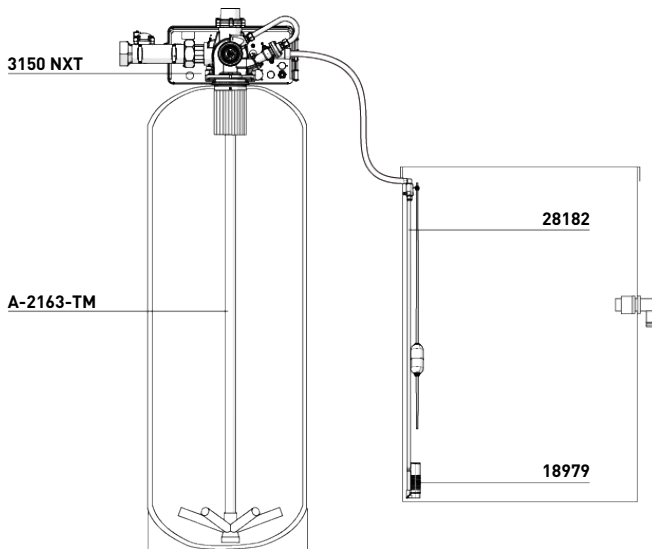

Side mounted configuration example

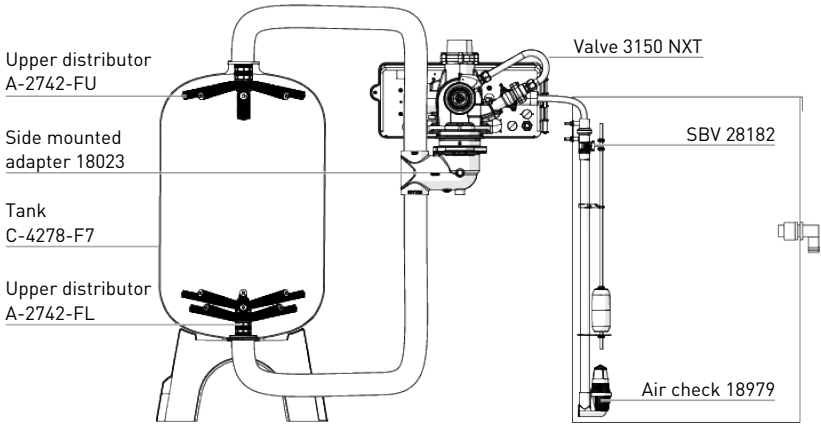

5.7 System types



Info

For all multiple tank systems #5 and #6, NBP version valves must be used.
 For all multiple tank systems #7, #8 (for NXT2 only), #9 and #14, WBP version valves must be used in combination with solenoid valve in the outlet.
 The solenoid valve needs to be connected to (P6 (for NXT) and P18 (for NXT2) OUTPUT – 24 VAC 50/60Hz, 0.25 A, MAX)



Info

In this chapter, systems up to four valves are used to describe and illustrate the different multiple valves systems, even if the described system may control more than four valves.

Metered immediate:

The controller monitors the volume of water used. As soon as the capacity is exhausted, the controller starts the regeneration process.

Metered delayed:

The controller monitors the volume of water used. When the remaining capacity is less than the programmed reserve, the controller queues a regeneration that will start at the programmed regeneration time.

Time clock:

The controller initiates the regeneration at regular preset time interval at the programmed regeneration time.

Remote regen start:

The controller initiates the regeneration when an external dry signal is acquired on the S2 terminal (see Electrical connections [▶ Page 52], signal must last at least the programmed signal duration).

For NXT2 controller only

Day of the week

The controller initiates the regeneration at the programmed regeneration time on preset day(s) of the week.

5.7.1 Single valve (System #4)

As named, this system works with only one valve. The regen can be initiated upon the treated volume (delayed or immediate), time clock mode or an external remote regen signal or day of week (NXT2 controller only).

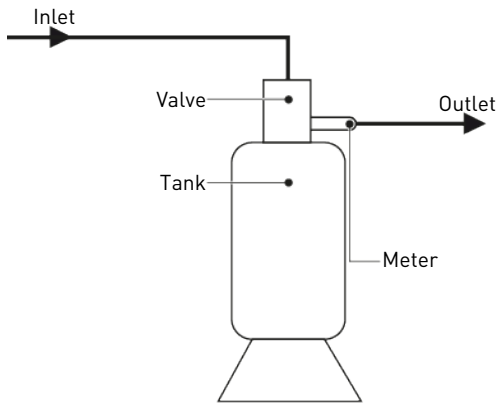

5.7.2 Multiple valves, parallel interlock system (System #5)

This system type may be used to build systems from 2 to 4 valves for NXT controller, 2 to 8 valves for NXT2. Each valve must be equipped with a water meter.

All tanks in parallel are supplying treated water. Each unit in the system has its own flow meter. The controller will delay the start of regeneration if another unit is already regenerating. Once that unit has completed a regeneration cycle and returned to service, the unit with longest regeneration queue time will begin regeneration. Only one unit regenerates at the time. Automatic regeneration may be triggered by either volumetric mean or external dry contact.

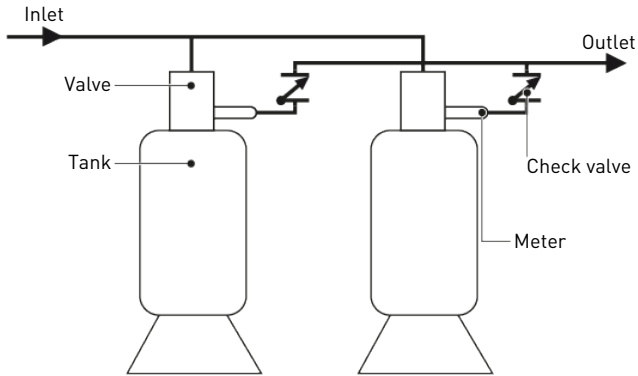

5.7.3 Multiple valves, parallel series regeneration system (System #6)

This system type may be used to build systems from 2 to 4 valves for NXT controller, 2 to 8 valves for NXT2. Only One water meter is required for the whole system.

During normal operation, the controllers of each valve display the time of day and the volume of water remaining. The remaining volume is the total volume of the system. The remaining volume displayed drops with water consumption to reach zero. When this happens, if no other valve is regenerating, the lead valve starts regeneration while sending out a regeneration lock out signal to all other valves of the system. If another valve is regenerating, the valve will stay in service until the other goes back in service. As soon as the lead valve finishes its regeneration cycle, the second valve starts regenerating, then the third, etc. The regenerating valve keeps on sending a regeneration lock out signal to all other valves of the system. A manual regeneration can only be done on the lead valve and only if the others are not regenerating. Automatic regeneration may be triggered by either volumetric mean or external dry contact.

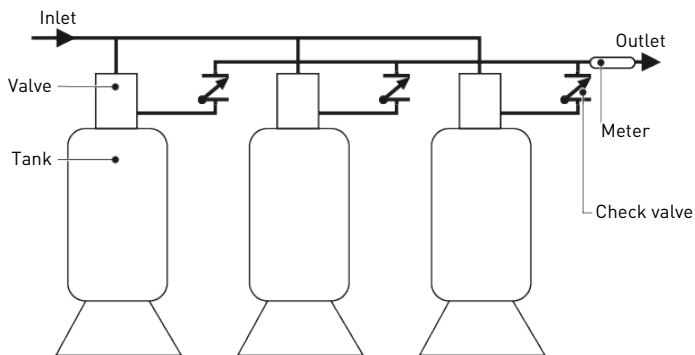

5.7.4 Duplex alternating immediate system (System #7)

This system works with 2 valves and a meter.

During normal operation, the controller of each valve displays the time of day and the remaining volume. The remaining volume displayed drops with water consumption to reach zero. When this happens, the regeneration starts immediately. The valve in service sends a signal to the valve in standby that goes in service. Once this occurs, the valve with exhausted capacity starts its regeneration process.

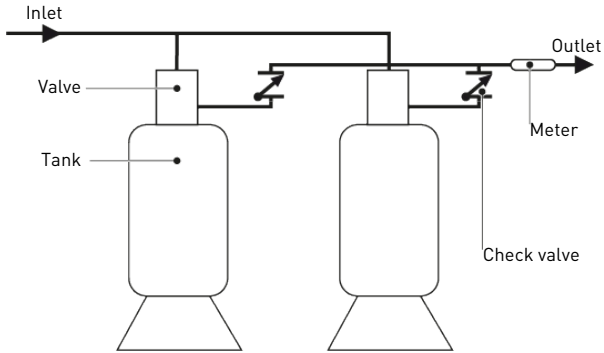

5.7.5 Duplex alternating delayed system (System #8) (NXT2 only)

This system works with 2 valves and a meter.

During normal operation, the controller of each valve displays the time of day and the volume of water remaining. The remaining volume displayed drops with water consumption to reach zero. When this happens, the valve in service books a regeneration that will start at the programmed regeneration time. When the programmed regeneration time is reached, the valve in service sends a signal to the valve in standby that moves into service position. Once the 2nd valve is in service, regeneration of the exhausted valve starts.

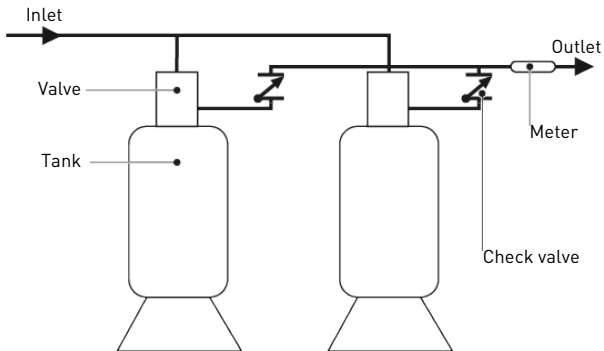

5.7.6 Multiple valves, parallel system with standby unit (System #9)

This system type may be used to build systems from 2 to 4 valves for NXT controller, 2 to 8 valves for NXT2. Each valve must be equipped with a water meter.

One to three tanks in service (NXT) or one to seven tanks in service (NXT2) supplying treated water, one tank in standby. The regeneration of an exhausted unit can start only after the unit in standby has returned to service position. When the regeneration cycle

is complete, the regenerated unit will enter in standby. Standby on each tank is controlled by the drive output terminals [24 VAC or 24 VDC, see UDM on Electrical connections [Page 52]] on the NXT/NXT2 circuit board.

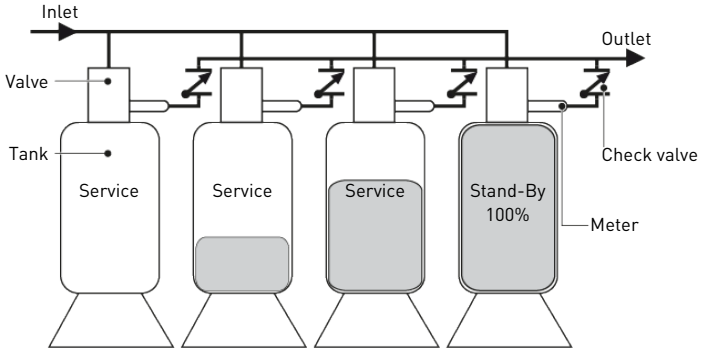

5.7.7 Multiple valves, system on-demand (System #14)

This system type may be used to build systems from 2 to 4 valves for NXT controller, 2 to 8 valves for NXT2. Each valve must be equipped with a water meter.

The number of tanks in service depends on the flow rate and on programmed settings.

5.7.7.1 Examples of a four units system

1. One tank is in service at all time (the "primary tank").

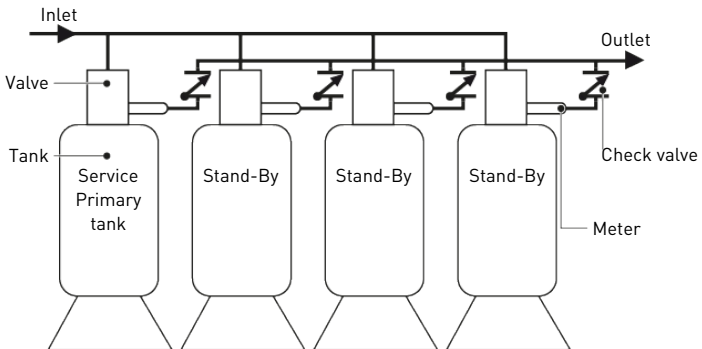

2. The total flow rate to the primary tank increases and exceeds the first programmed trip point. The flow rate demand stays above the trip point for the preset delay time. The next tank (with the least remaining volume) changes from standby into service. This then splits the total flow between two meters.

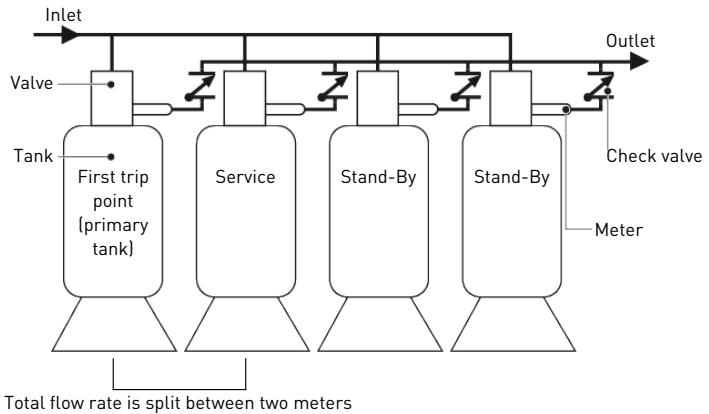

3. The flow rate demand decreases below the first trip point. The tank returns to standby.

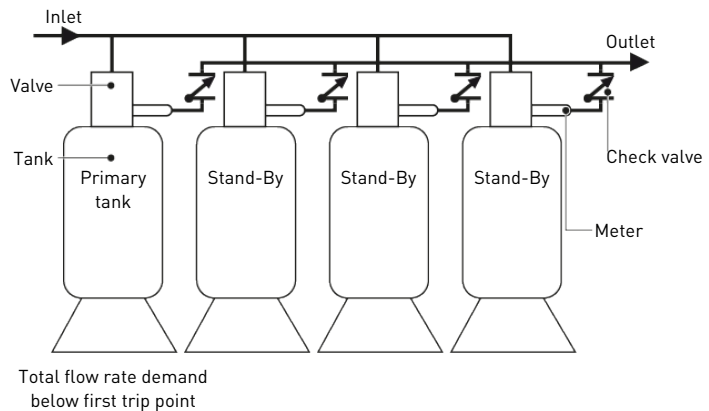

4. Total flow rate demand increases and exceeds the second trip point for a longer period than the programmed delay time. The second and third tank (with the least remaining volumes) change from standby to service. The total flow is split between three meters.

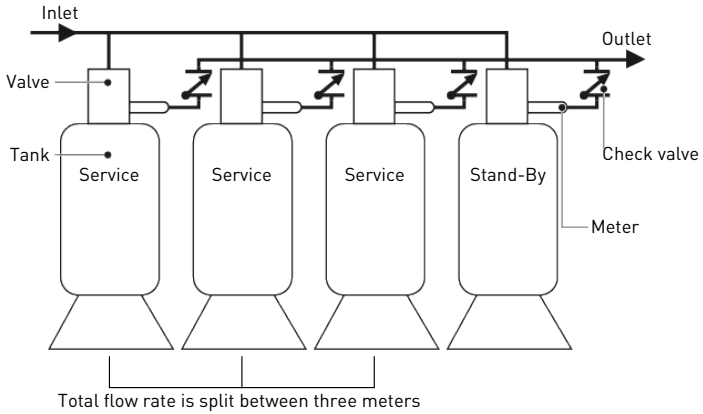

- The third tank returns to standby as demand decreases and returns below the second trip point.

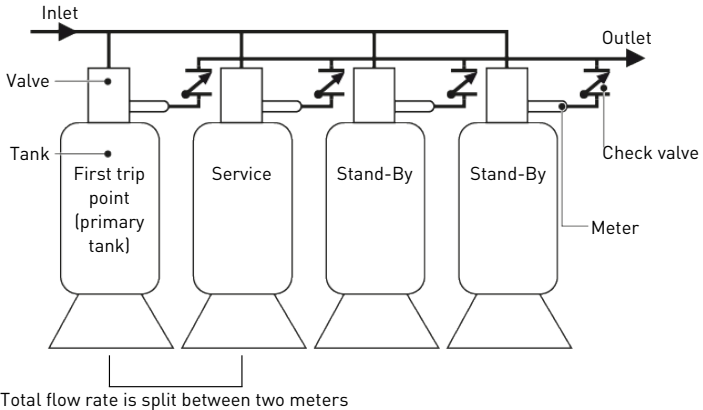

- Tanks return to standby due to decreased total flow rate and programmed trip points. The tank with the most remaining volume will be the first to go into standby.

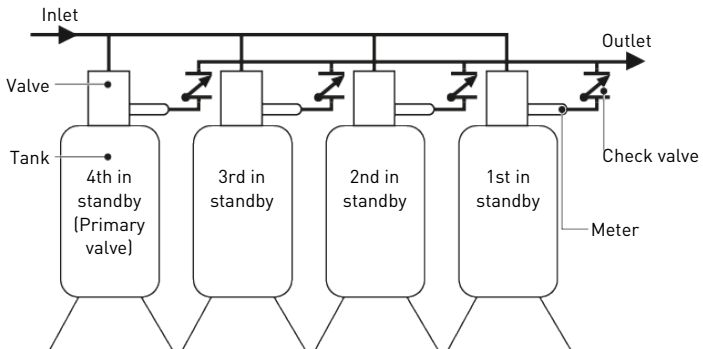

5.7.7.2 System operation in regeneration

The primary tank regenerates when its remaining volume becomes zero. The next tank with the least remaining volume becomes the new primary tank. The tank with the next least volume remaining will be the first to be activated when the flow rate reach the programmed trip point. Tanks continue operating in this order.

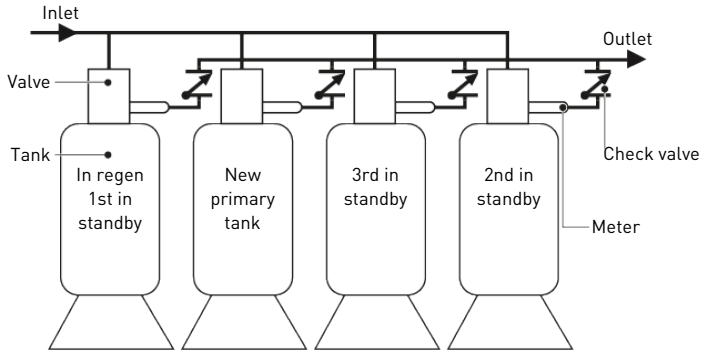

If two tanks are in service and both becomes exhausted at the same time, the other two tanks will shift from standby into service. The lead tank with exhausted capacity will start regeneration. The second tank with exhausted capacity will enter into standby. If the flow increases and exceed the trip point, a third tank must move into service position. The tank in standby with exhausted capacity will shift into service to maintain a steady flow. Operating for extended periods in this mode may degrade the water quality.

5.8 Electrical connections

CMN:	Common	STRT:	Remote regen start
FM:	Flow meter	SV:	Solenoid valve
GND:	Ground	Sw1:	Upper piston switch
HCAM:	Upper piston cam	Sw2:	Brine valve switch
LCK:	Remote regen lock	Sw3:	Lower piston switch
LDCAM:	Lower piston cam	UDM:	Upper power head motor
LDM:	Lower power head motor	W1:	Black wire
NC:	Normally closed	W2:	Red wire
NO:	Normally open	W3:	Brown wire
RST:	Reset button	W4:	Yellow wire
S1:	Inhibition signal (when contact is closed)	W5:	White wire
S2:	Remote regen signal start (when contact is closed)	W6:	Blue wire
S3:	External signal during service or regeneration	W7:	Orange wire
S4:	Dry contact switch function	W8:	Violet wire
S5:	Relay (5A 30 VDC - 10A 250 VAC)	W9:	Green wire
SCAM:	Brine valve cam	W10:	Black and white wire

5.8.1 NXT controller connections

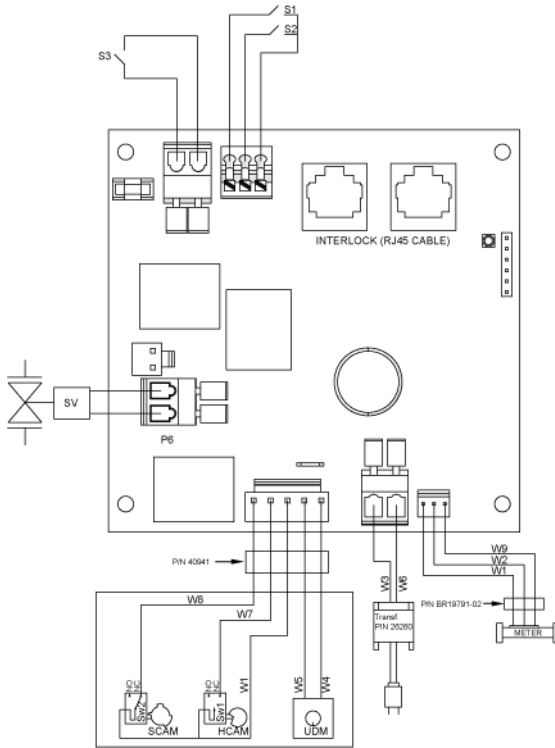

5.8.2 NXT2 controller connections



CAUTION

Do not connect 24V (AC or DC) power supply on the Lower piston switch connector P17, as this would immediately and irreversibly damage the electronic board.

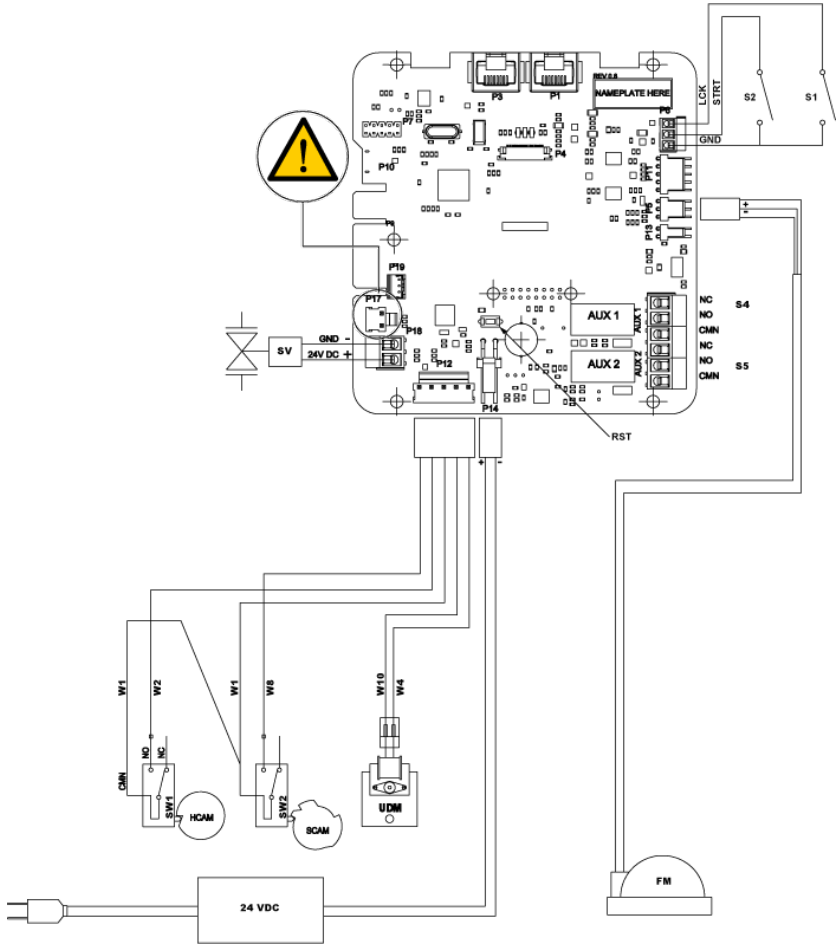

5.8.3 NXT controller connections for multiple valves

2 controllers NXT

Duplex system #5, #6, #7, #9 & #14

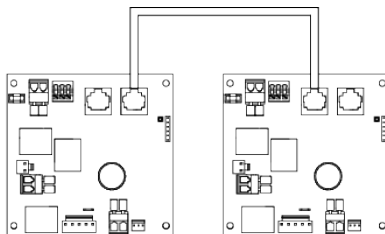

3 controllers NXT

Triplex system #5, #6, #9 & #14

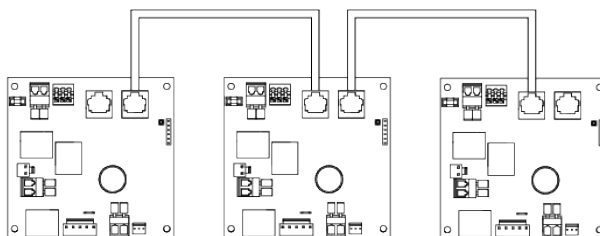

4 controllers NXT

Quadriplex system #5, #6, #9 & #14

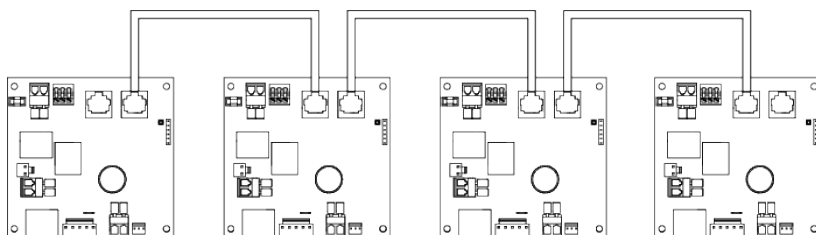

Info

The valve with address#1 must not be at the left or right extremity of the system in order to ensure proper information communication in between the 4 valves of the system.

5.8.4 NXT2 controller connections for multiple valves



Mandatory

Use CAT5 (with RJ45 connector) or better twisted pair cables with a maximum length of 30 meters.

2 controllers NXT2

Duplex system #5, #6, #7, #8, #9 & #14

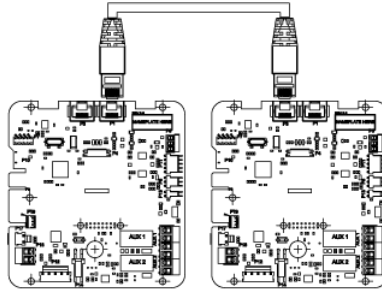

3 controllers NXT2

Triplex system #5, #6, #9 & #14

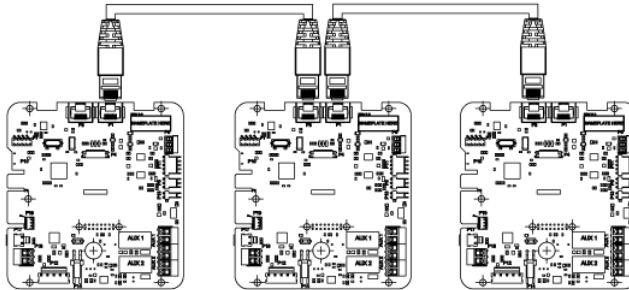

4 to 8 controllers NXT2

Multiplex system #5, #6, #9 & #14

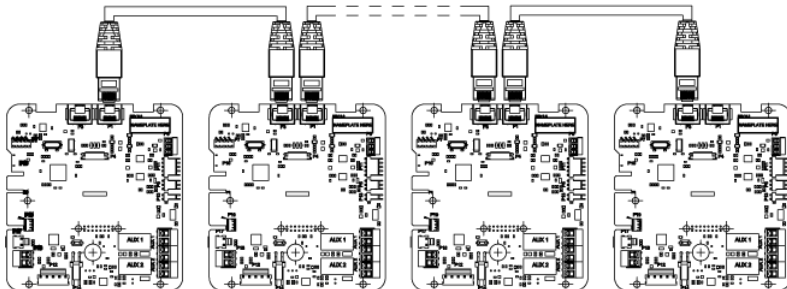

5.9 Bypassing

A bypass valve system should be installed on all water conditioning systems. Bypass valves isolate the softener from the water system and allow unconditioned water to be used. Service or routine maintenance procedures may also require that the system is bypassed.

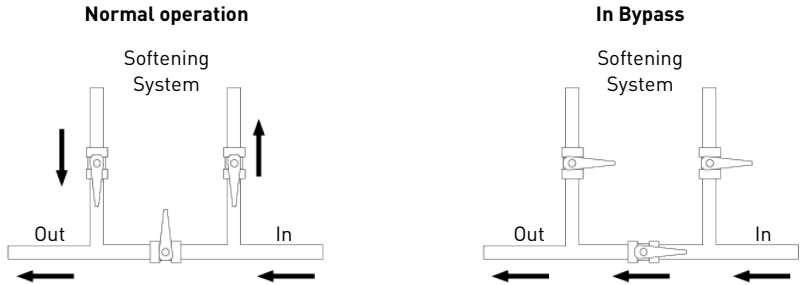

CAUTION

Do not solder pipes with lead-based solder.



CAUTION

Do not use tools to tighten plastic fittings. Over time, stress may break the connections.



CAUTION

Do not use petroleum grease on gaskets when connecting bypass plumbing. Use only 100% silicone grease products when installing any plastic valve. Non-silicone grease may cause plastic components to fail over time.

5.10 Drain line connection



Info

Standard commercial practices are expressed here. Local codes may require changes to the following suggestions. Check with local authorities before installing a system.



Mandatory

The drain line must be build with 2" PVC rigid tube. An air gap must be present at the drain.



CAUTION

Flexible and semi-flexible hoses may bend and whip during draining.

The drain line may be elevated up to 1.8 m provided the run does not exceed 4.6 m and water pressure at the softener is not less than 2.76 bar. Elevation can increase by 61 cm for each additional 0.69 bar of water pressure at the drain connector.

Where the drain empties into an overhead sewer line, a sink-type trap must be used.

Secure the end of the drain line to prevent it from moving.



Info

Waste connections or the drain outlet shall be designed and constructed to provide connection to the sanitary waste system through an air-gap of 2 pipe diameters or 100.6 mm (4"), whichever is larger.



CAUTION

Never insert the drain line directly into a drain, sewer line or trap. Always allow an air gap between the drain line and the waste water to prevent the possibility of sewage being back-siphoned into the softener.

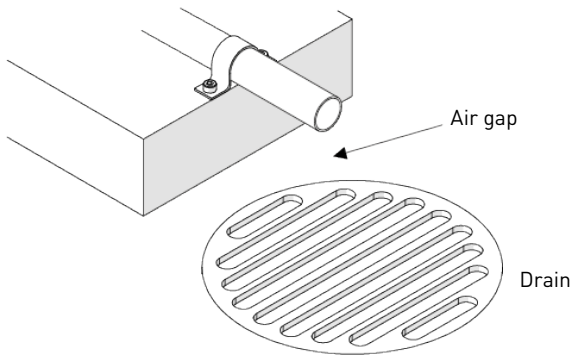

5.11 Overflow line connection

In the event of a malfunction, the brine tank overflow fitting will direct "overflow" to the drain instead of spilling on the floor. This fitting should be on the side of the brine tank. Most brine tank manufacturers features a pre-drilled hole for the tank overflow connector.

To connect the overflow line, locate the hole on the side of the tank. Insert the overflow fitting into the tank and tighten with plastic thumb nut and gasket as shown below. Attach a 25.4 mm (1") I.D. tubing (not supplied) to fitting and run to drain.

Do not elevate overflow higher than overflow fitting.

Do not tie into the drain line of the controller unit. The overflow line must be a direct, separate line from overflow fitting to drain, sewer or tub. Allow an air gap as per drain line instructions.

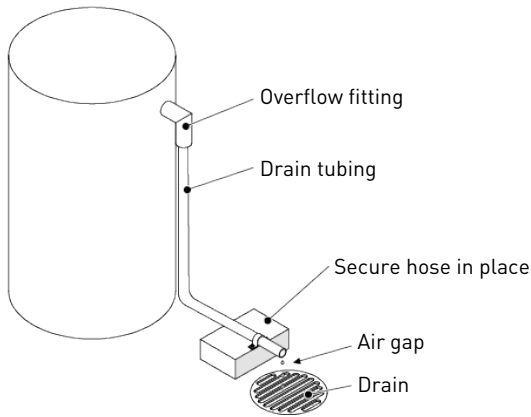

CAUTION

Floor drain is always recommended to avoid flooding in case of overflow.

5.12 Brine line connection



Mandatory

Brine line with 1600/1650 brine valve: 3/8" semi rigid piping.

Brine line with 1700/1710 brine valve: 1/2" semi rigid or rigid piping.



CAUTION

Flexible and semi-flexible hoses may shrink because of the vacuum during brine draw.

The brine line from the tank connects to the valve. Make the connections and hand tighten. Be sure that the brine line is secure and free from air leaks. Even a small leak may cause the brine line to drain out, and the softener will not draw brine from the tank. This may also introduce air into the valve, causing problems with the valve operation.

Brine line must be equipped with brine tank air check in the brine tank.

6 Programming

6.1 NXT controller

6.1.1 Display

6.1.1.1 During service

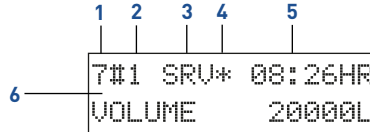

1. System type
 - #4: single valve;
 - #5: Multiple valves, parallel interlock system, 2 to 4 valves;
 - #6: Multiple valves, parallel series regeneration system, 2 to 4 valves;
 - #7: duplex alternating immediate system, 2 valves;
 - #9: Multiple valves, parallel system with standby unit, 2 to 4 valves;
 - #14: Multiple valves, system on-demand, 2 to 4 valves.
2. Valve address
 - #-: single valve;
 - #1: address 1, lead valve;
 - #2: address 2;
 - #3: address 3;
 - #4: address 4.
3. Valve status
 - CHG (change of state): lower drive changes position on double piston valve;
 - INI (initializing): after a power failure or a change in the programming, the controllers initializes for approximately 30 seconds;
 - RGQ (regeneration queued): in a meter delayed system, the reserve capacity has been entered or a manual regeneration has been registered;
 - LCK (lock): the controller has acquired the lockout signal;
 - SRV (service): valve in service;
 - SBY (standby): valve in standby.
4. Flow indicator
 - rotates when flow is going through the meter.
5. Time of the day

- 6. Operating mode
 - remaining volume in volumetric mode;
 - remaining days before regeneration in timeclock mode.

6.1.2 Commands







Info

At any time, press **D** to return to the home screen without saving.



Info

Menus are displayed in a defined and incremental order.

- a) Press  to pass to the next step.
- b) Use  to move the cursor to the next digit.
- c) Use  and  adjust the values.
- d) Press **D** at any time to exit programming mode without saving.

6.1.3 Setting the time of the day

Set the time in the system.



Mandatory

In multiple valve systems, set the time of day on the lead valve (#1).









Info

The time of day will be automatically updated on the other valves in the system within 10 seconds.



Info

If, during time setting, no buttons are pushed for 5 seconds, the system leaves setting.

- a) Press  or  for 2 seconds.
- b) Set the controller with ,  and .
- c) Press  to validate the selection and return to the service mode.

SET TIME OF DAY:
08:43HR

6.1.4 Basic programming



Info

Menus are displayed in a defined and incremental order.

6.1.4.1 Basic programming mode chart

Parameter	Options	Definition	Note
LANGUAGE	ENGLISH	English	
	FRANCAIS	French	
	DEUTSCH	German	
	ITALIANO	Italian	
	ESPANOL	Spanish	
FEED WATER HARDNESS	1 to 1'999	Milligram CaCO ₃ /L	This screen will only display on the lead unit for system types 6 & 7. For all other system types, it will display for all units.
REGENERATION DAY OVERRIDE	OFF to 99	Day.	Use the SHIFT button to move to the left.
REGENERATION TIME	00:00:00 to 23:59:59	Hour	Regeneration time will not appear unless regeneration day override or timeclock is on.

6.1.4.2 Language setting

Select the displayed language.

Options:

- English;
- French;
- German;
- Italian;
- Spanish.

a) Press and simultaneously for 5 seconds to enter the menus sequence.

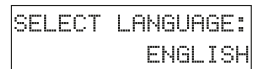

b) Select the language to be displayed with and .

c) Press to validate the selection and advance to the next parameter.

6.1.4.3 Inlet water hardness

Set the inlet water hardness in the unit defined on chapter Units [▶ Page 101]

a) Set the inlet water hardness with , and .

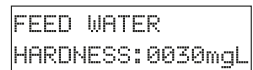

b) Press to validate the selection and advance to the next parameter.





6.1.4.4 Regeneration days override

Set the maximum number of days that the valve is in service without regenerating, regardless from the volume of water used.



Info

For a timeclock valve, this value must be set. For metered valves, calendar override parameter would trigger a regeneration only if the volumetric control did not start a regeneration before calendar override period elapsed. Each volumetric regeneration happening reset the calendar override delay.

- a) Adjust the number of days with ,  and .
- b) Press  to validate the selection and advance to the next parameter.
 - ⇒ Can be adjusted from:
 - 1 to 99 days for timeclock regeneration;
 - OFF to 99 days for metered regeneration.

Without calendar override.

```
REGENERATION DAY
OVERRIDE: OFF
```

override every 3 days.

```
REGENERATION DAY
OVERRIDE: 03DAYS
```





6.1.4.5 Regeneration start time

Set the time for regeneration start.



Info

It must be set when the regeneration mode programmed is timeclock or with a metered calendar override.

- a) Adjust the time of regeneration with ,  and .
- b) Press  to validate the selection and return to service.

Regeneration at 2:00 am.

```
REGENERATION
TIME      02:00HR
```

6.1.5 Master programming mode



Info

As soon as programming mode is entered, all parameters can be displayed or set to suit the needs. Depending on the current programming, some functions will not be displayed or will not be changeable.



Info

If none of the buttons are pushed for 5 minutes in the Programming mode, or if there is a power failure, the controller returns to Service mode without saving.



Mandatory

In order to store the new settings in the programming mode, it is necessary to go through all the parameters.

6.1.5.1 Master programming mode chart



Parameter	Options	Definition	Note
LANGUAGE	ENGLISH	English	
	FRANCAIS	French	
	DEUTSCH	German	
	ITALIANO	Italian	
	ESPANOL	Spanish	
SYSTEM TYPE	4	Single unit	1 unit.
	5	Parallel interlock	2 to 4 units.
	6	Parallel series regeneration	
	7	Alternating immediate	2 units.
	9	Parallel with standby unit	2 to 4 units.
	14	On-demand	
VALVE ADDRESS	#1	First control valve	This screen will not be displayed for system type 4.
	#2	Second control valve (default)	
	#3	Third control valve	
	#4	Fourth control valve	
SYSTEM SIZE	2	2 valves in the system	This screen will not be displayed for system type 4.
	3	3 valves in the system	
	4	4 valves in the system	

Parameter	Options	Definition	Note
REGEN TYPE	TIME CLK DELAYED	Time clock delayed (default)	System 4 only.
	METER IMMEDIATE	-	All system types.
	MTR DLY FIX RSV	Metered delayed fixed reserve	Systems 4 & 6 only.
VALVE TYPE	2750	-	
	2850	-	
	2900/2910	-	
	3150	-	
	3900	-	
	STAGER-NOTCH CAM	-	
REGENERANT FLOW	DOWN FLOW	-	
	UP FLOW	-	
REMOTE SIGNAL START	OFF to 99 minutes	-	This screen will not be displayed for system type 14.
DISPLAY FORMAT	US-GALLONS	US units (default)	
	EU-METRIC-LITERS	Metric units	
UNIT CAPACITY	1 to 198'000	Gram CaCO ₃	Use the SHIFT button to move to the left.
CAPACITY SAFETY FACTOR	0 to 50	%	
FEED WATER HARDNESS	1 to 1'999	Milligram CaCO ₃ /L	This screen will only display on the lead unit for system types 6 & 7. For all other system types, it will display for all units. Use the SHIFT button to move to the left.
TRIP POINT 1	1 to 3997	L/m	This screen will only display for system 14 and will only appear on the master controller (Valve address #1). Use the SHIFT button to move to the left.
TRIP DELAY 1	30 to 99	Second (30 seconds default)	

Parameter	Options	Definition	Note
TRIP POINT 2	1 to 3997	L/m	This screen will only display for system 14 and will only appear with the system sized to 3 or 4 on the master controller (Valve address #1). Use the SHIFT button to move to the left.
TRIP DELAY 2	30 to 99	Second (30 seconds default)	
TRIP POINT 3	1 to 3997	L/m	This screen will only display for system 14 and will only appear with the system sized to 4 on the master controller (Valve address #1). Use the SHIFT button to move to the left.
TRIP DELAY 3	30 to 99	Second (30 seconds default)	
REGENERATION DAY OVERRIDE	OFF to 99	Day	Days between regenerations for timeclock mode.
REGENERATION TIME	00:00:00 to 23:59:59	Hour	Regeneration time will not appear unless regeneration day override or timeclock is on.
CYCLE 1	OFF to 04:00:00		
CYCLE 2	OFF to 04:00:00		
CYCLE 3	OFF to 04:00:00		
CYCLE 4	OFF to 04:00:00		
CYCLE 5	OFF to 04:00:00		
			This screen will only display when cycle 4 is not OFF.
AUXILIARY RELAY	Enabled	-	Not compatible with CPO AUX activation.
	Disabled	(Default)	
AUX RELAY OUTPUT START	00:00:00 to 18:00:00	Hour	Only displayed if auxiliary relay is enabled in previous screen.
AUX RELAY OUTPUT END	00:00:00 to 18:00:00		Auxiliary relay will only display if chemical pump is OFF for system types 6 & 7.
CHEMICAL PUMP	Enabled	-	This screen will only display on the lead (#1) unit for system types 6 & 7. For all other system types, it will display for all units.
	Disabled	(Default)	

Parameter	Options	Definition	Note
CPO AUX RELAY VOLUME	1 to 9'999	L	Activate the relay output during a service based upon the volume of treated water. Relay is activated for a set time after every set volume is treated. Not compatible with aux. relay activation.
CPO AUX RELAY TIME	00:00:00 to 02:00:00	Hour	
FLOW METER	1.0" PADDLE	-	Default flow meter type is based on the valve type. This screen will only display on the lead (#1) unit for system types 6 & 7. All other system types it will display for all units.
	1.0" TURBINE	-	
	1.5" PADDLE	-	
	1.5" TURBINE	-	
	2.0" PADDLE	-	
	3.0" PADDLE	-	
	GENERIC	-	
PEAK FLOW RATE	20 to 2'000	l/min	Only displayed if "Generic" is chosen for the flow meter.
ADD XXX LITERS EVERY YYY PULSES	1 to 255	XXX: number of liter YYY: number of pulses	

6.1.5.2 Entering master programming mode

- a) Press  and  simultaneously for 5 seconds to enter the master programming mode.



```
7#1 SRU* 08:26HR
VOLUME 20000L
```

6.1.5.3 Language setting

Select the displayed language.

Options:

- English;
- French;
- German;
- Italian;
- Spanish.

- a) Select the language to be displayed with  and .
- b) Press  to validate the selection and advance to the next parameter.

```
SELECT LANGUAGE:
ENGLISH
```

6.1.5.4 System type

Select the system in which the valve(s) operate(s).

Options:

- 4: single valve;
- 5: multiple valves, parallel interlock system;
- 6: multiple valves, parallel series regeneration system;
- 7: duplex alternating immediate system;
- 9: multiple valves, parallel system with standby unit;
- 14: multiple valves, system on-demand.

a) Set the system type with and .

b) Press to validate the selection and advance to the next parameter.

Example: 4 Single valve.

SYSTEM TYPE	:4
SIMPLEX	

Example: 5 multiple valves.

5#1 RQG*	10:15HR
VOLUME	3000L

6.1.5.5 Valve address in the system

Set the valve position in the system.



Info

Only visible in systems 5, 6, 7, 9 and 14.





Info

The number #1 is the lead valve (master) and contains the programmed parameters used by the other controllers in the system in order to control the regeneration and service or standby positions.

Options:

- address #1: valve 1, lead (master);
- address #2: valve 2;
- address #3: valve 3;
- address #4: valve 4.

- a) Set the valve position with  and .
 ⇨ Default setting: valve 2 address #2.
- b) Press  to validate the selection and advance to the next parameter.

Example: Valve #1 (master).

VALVE	ADDRESS
	#1

Example: Valve #2.

VALVE	ADDRESS
	#2

6.1.5.6 System size

Set the number of valves to be connected (2 to 4 valves) in the system.





Info

Only visible in multiple valve systems and only present on the master #1 valve.

Options:

- 2 valves in the system;
- 3 valves in the system;
- 4 valves in the system.

- a) Adjust the system size with  and .
 ⇨ Default setting: 2 valves.
- b) Press  to validate the selection and advance to the next parameter.



SYSTEM SIZE	:
	2 VALVES

6.1.5.7 Regeneration type

Select the regeneration type.

Options:

- time clock delayed: regeneration will take place, at the programmed regeneration time, after the set amount of days has been reached (available only for system type 4);
- volume delayed: regeneration is requested when the volume of treated water reaches the reserve capacity and will take place, at the programmed regeneration time (available only for system type 4);
- volume immediate: regeneration is requested when the capacity is fully depleted. The regeneration starts immediately (available for all system types).

- a) Set regeneration type with  and .
 ⇨ Default setting: time clock delayed.
- b) Press  to validate the selection and advance to the next parameter.

REGEN TYPE
TIME CLK DELAYED

6.1.5.8 Valve type

Select which valve is being used with the NXT.

Options:

- 2750;
- 2850;
- 2900/2910;
- 3150;
- 3900.

a) Set valve type at 3150 with and .

⇒ Default setting: 2750

VALUE TYPE: 3150

b) Press to validate the selection and advance to the next parameter.

6.1.5.9 Regeneration flow

Set the direction of flow during the brine draw cycle.



Info

The availability depends on the valve type programmed in the previous step.

Options:

- down flow;
- up flow (not for 2850 valve type);
- up flow fill first (only for 2750 and 2900/2910 types).

a) Set regeneration flow with and .

⇒ Default setting: down flow

REGENERANT FLOW DOWN FLOW

b) Press to validate the selection and advance to the next parameter.

6.1.5.10 Remote started regeneration

Start regeneration from an external signal (see chapter Electrical connections [▶Page 52]).



Info

The contact will close after a preset duration. When the contact closes, the regeneration starts.



Info

This mode can be combined with the other methods of regeneration; it has priority once it is activated.

- a) Set the remote controller with \swarrow , \searrow and \leftarrow .
 ⇒ Can be adjusted from OFF to 01:39:00.
- b) Press  to validate the selection and advance to the next parameter.

Without remote controller.

```
REMOTE SIGNAL
START:OFF
```

With remote controller and 1 minute contact programmed.

```
REMOTE SIGNAL
START: 00:01:00
```

6.1.5.11 Display format

Set the unit system to be used.

Options:

- US GALLONS: volume in gallons, time display 2 x 12 hours, hardness in grains;
- EU-METRIC-LITERS: volume in liter, time display 24 hours and hardness depends on the language:

EN: mg/L as CaCO₃ FR: °F GE: °dH IT: °TH SP: °TH

- a) Set the display format with \swarrow and \searrow .
- b) Press  to validate the selection and advance to the next parameter.

```
DISPLAY FORMAT
EU-METRIC-LITER
```

6.1.5.12 System capacity

Set the capacity of the tank where the valve is installed.



Info

Based on system capacity, safety coefficient and inlet water hardness, the controller calculates the volume of water that the system can treat between 2 regenerations.

- a) Set the unit capacity with \swarrow , \searrow and \leftarrow .
- b) Press  to validate the selection and advance to the next parameter.

Example: 3000 g of CaCO₃ of capacity.

```
UNIT CAPACITY
003000 gCaCO3
```

This volume corresponds to the volume the tank could treat if the inlet water hardness is 1°F, 1°TH or 1°dH.

6.1.5.13 Safety coefficient

Set the percentage value by which the total capacity is reduced as a safety coefficient.

- a) Set the safety coefficient with \swarrow , \searrow and \leftarrow .
 ⇒ Can be adjusted from 0 to 50%.

No safety factor programmed.

- b) Press to validate the selection and advance to the next parameter.

```
CAPACITY SAFETY
FACTOR 00%
```

6.1.5.14 Inlet water hardness

Set the inlet water hardness in the unit set on chapter Units [▶Page 101]

- a) Set the inlet water hardness with \swarrow , \searrow and \leftarrow .
- b) Press to validate the selection and advance to the next parameter.

```
FEED WATER
HARDNESS:0030mgL
```

6.1.5.15 Trip points setting

Set the flow rate and switching delay when another tank is switched to service.



Info

Only visible in system 14.

Trip point 1



Info

Only visible if controller programmed as valve position #1.

- a) Set the trip point 1 flow rate with \swarrow , \searrow and \leftarrow .
 ⇒ Can be adjusted from 0 to 3997 l/min.

```
TRIP POINT 1:
0000Lpm
```

- b) Press to validate the selection and advance to the next parameter.

```
TRIP DELAY 1
30 SECONDS
```

- c) Set the trip point 1 delay with \swarrow , \searrow and \leftarrow .
 ⇒ Can be adjusted from 30 to 99 seconds.









- d) Press to validate the selection and advance to the next parameter.

Trip point 2



Info

Only visible if controller programmed as valve position #1 and system size to 3 or 4.

- a) Set the trip point 2 flow rate with ,  and .
 - ⇒ Can be adjusted from trip point 1+1 to 3998 l/min.
- b) Press  to validate the selection and advance to the next parameter.
- c) Set the trip point 2 delay with ,  and .
 - ⇒ Can be adjusted from 30 to 99 seconds.
- d) Press  to validate the selection and advance to the next parameter.

```
TRIP POINT 2:
0000Lpm
```









```
TRIP DELAY 2
30 SECONDS
```

Trip point 3



Info

Only visible if controller programmed as valve position #1 and system size to 4.

- a) Set the trip point 3 flow rate with ,  and .
 - ⇒ Can be adjusted from trip point 2+1 to 3999 l/min.
- b) Press  to validate the selection and advance to the next parameter.
- c) Set the trip point 3 delay with ,  and .
 - ⇒ Can be adjusted from 30 to 99 seconds.
- d) Press  to validate the selection and advance to the next parameter.

```
TRIP POINT 3:
0000Lpm
```

```
TRIP DELAY 3
30 SECONDS
```





6.1.5.16 Regeneration days override

Set the maximum number of days that the valve is in service without regenerating, regardless from the volume of water used.



Info

For a timeclock valve, this value must be set as regeneration period in days. For metered valves, it is regenerated once the amount of days is reached at a preset time unless the meter triggers regeneration before. Calendar override initiate regeneration only if no regeneration has been initiated within the delay programmed in calendar override parameter.

- a) Adjust the number of days with ,  and .
- b) Press  to validate the selection and advance to the next parameter.
 - ⇒ Can be adjusted from:
 - 1 to 99 days for timeclock regeneration;
 - OFF to 99 days for metered regeneration.

Without calendar forcing.

```
REGENERATION DAY
OVERRIDE: OFF
```

Forcing every 3 days.

```
REGENERATION DAY
OVERRIDE: 03DAYS
```

6.1.5.17 Regeneration start time

Set the time for regeneration start.



Info

It must be set when the valve is in timeclock mode or with a calendar override.

- a) Adjust the time of regeneration with , and . Regeneration at 2:00 am.
- b) Press to validate the selection and advance to the next parameter.

```

REGENERATION
TIME          02:00HR
    
```

6.1.5.18 Programming regeneration cycle times

Set the cycle times of the regeneration.



Info

Five cycles can be set. The system displays the programming cycles. The display allows setting of a specific time for each cycle. If a cycle is set to NO, the next cycles is not activated.



Info

The sequence of the regeneration cycles depends upon regenerant flow, see System regeneration cycle [▶ Page 20].

- a) Adjust the cycle time with , and .
- b) Press to validate the selection and advance to the next parameter.
- c) Repeat for each cycle.

1. Backwash: 10 min.

```

CYCLE 1 00:10:00
          BACKWASH
    
```

2. Draw/Slow rinse:
1 h 10 min.

```

CYCLE 2 01:10:00
          BRINE&SLOW RINSE
    
```

3. Fast rinse: 10 min.

```

CYCLE 3 00:10:00
          RAPID RINSE
    
```

4. Refill: 10 min.

```

CYCLE 4 00:10:00
          BRINE TANK FILL
    
```

5. Pause: not used.

```

CYCLE 5 NO
          PAUSE & DELAY
    
```

6.1.5.19 Auxiliary relay/Chemical pump



Mandatory

The system can't be set with auxiliary relay and chemical pump at the same time. Only one option can be used.











Auxiliary relay

Set the relay output during regeneration.



Info

This parameter has two steps of settings. The first one activates the output, and the second one deactivates the output. The time 00:00:00 correspond to the beginning of regeneration time.

- a) Activate the relay with  and .
- b) Default setting: disabled.
- c) Press  to validate the selection and advance to the next parameter.
- d) Set the relay activation time with ,  and .
- e) Press  to validate the selection and advance to the next parameter.
- f) Set the relay deactivation time with ,  and .
- g) Press  to validate the selection and advance to the next parameter.

Disabled.

```
AUXILIARY RELAY:
DISABLED
```

Relay enabled at the beginning of regeneration.

```
AUX RELAY OUTPUT
START: 00:00:00
```

Relay disabled 10 min. after the start of regeneration.

```
AUX RELAY OUTPUT
END: 00:10:00
```

Relay enabled during cycle 2 as in chapter Programming regeneration cycles time [▶Page 108].

```
AUX RELAY OUTPUT
START: 00:10:00
```

```
AUX RELAY OUTPUT
END: 01:20:00
```

Chemical pump

Activate the relay output during the service based upon the volume of treated water.



Info

Only visible in metered systems.



Info

This parameter has two steps. The first one determines the volume which activates the relay. The second one determines how long the relay has to be activated once the volume has passed.

- a) Activate the relay with and .
- b) Default setting: disabled.
- c) Press to validate the selection and advance to the next parameter.
- d) Set the relay activating time with , and .
- e) Press to validate the selection and advance to the next parameter.
- f) Set the relay deactivating time with , and .
- g) Press to validate the selection and advance to the next parameter.

Disabled.

```
CHEMICAL PUMP:
DISABLED
```

Relay enabled every
20 liter.

```
CPO AUX RELAY
VOLUME: 0020 L
```

Relay enabled for 1 min.

```
CPO AUX RELAY
TIME : 00:01:00
```

6.1.5.20 Flow meter selection

Select the size of the flow meter.

Options:

- 1.0" paddle (standard for 2750 valve series);
- 1.0" turbine;
- 1.5" paddle (standard for 2815 and 2850 valve series);
- 1.5" turbine;
- 2.0" paddle (standard for 2900 and 3150 valve series);
- 3.0" paddle (standard for 3900 valve series);
- generic meter.

- a) Select the flow meter with and .
- b) Press to validate the selection and advance to the next parameter.

```
FLOW METER
2.0" PADDLE
```

Generic meter



Info

Only visible if "generic" was selected in flow meter selection.

Set the generic meter.





Info

This parameter has two settings. The first display is to enter the maximum flow rate of the water meter. The second display is to enter the values for the flow meter (pulses and volume).

- a) Set the maximum flow rate with \swarrow , \searrow and \leftarrow . Example: 290 L/min.

PEAK FLOW
0290 lpm
- b) Press  to validate the selection and advance to the next parameter.
- c) Set the number of liters per pulse(s) with \swarrow , \searrow and \leftarrow . Example: 1 liter for 1 pulse.

ADD 001 LITER
EVERY 001 PULSES
- d) Press  to validate the selection and advance to the next parameter.
- e) Set the number of pulses for the programmed number of liters with \swarrow , \searrow and \leftarrow . Example: 5 liter for 1 pulse.

ADD 005 LITERS
EVERY 001 PULSES
- f) Press  to validate the selection and advance to the next parameter.

ADD 002 LITERS
EVERY 010 PULSES

6.1.5.21 Parameters saving



Info

When the last parameter is set and the button  pressed, the controller updates the database based on the new programming. Wait until programming is finished, this may take a few seconds.

PROGRAMMING UNIT
PLEASE WAIT...

6.1.6 Diagnostic



Info

Depending on current settings, some displays cannot be viewed.



Info

There is no time limit on the displays in the Diagnostic mode.

6.1.6.1 Commands

- a) Press **D** to enter the Diagnostic mode.
- b) Press  to pass at the next step.
- c) Press **D** to exit the Diagnostic mode at any time.

6.1.6.2 Current flow rate



Info

The display is updated every second.

```
CURRENT FLOW RAT
L/min           0Lpm
```

6.1.6.3 Peak flow rate



Info

The controller registers the highest flow rate since the last regeneration.



```
PEAK FLOW RATE
                0Lpm
```

6.1.6.4 Totalizer



Info

The controller registers the total volume of treated water that passes through the meter since start-up (or last hard reset).

- a) To reset, press and hold the buttons  and  for 5 seconds until the display shows zero.

```
TOTALIZER      :
                0 L
```

6.1.6.5 Hours between last two regenerations



Info

Shows the number of hours between the last two regenerations, which indicates the duration of the last service cycle.

```

2 LAST      REGEN
              0 HOUR
    
```

6.1.6.6 Hours since last regeneration



Info

Shows the number of hours since the last regeneration, indicating the duration of the current service cycle.

```

LAST      REGEN.
              0 HOUR
    
```

6.1.6.7 Volume remaining



Info

Shows the volume remaining for the valve where controller is installed, excepted for system #6 where it shows the volume remaining of the complete system.

In system #4, #5, #7, #9 and #14.

```

VOL REMAINING
              100000L
    
```

In system #6 (complete system).

```

VOL REMAIN SYST
              0100000L
    
```

6.1.6.8 Valve position



Info

Shows the position of the valve in a multiple valve system, also called the valve address.

```

VALVE POSITION:
              #2
    
```

6.1.6.9 Software version



Info

Shows the version of the software used by the controllers.



Mandatory

In case of use of multiple valves system, verify the controller's software compatibility.

```
3200NXT:
VERSION 2.04
```

6.1.7 Resetting the controller



Mandatory

Once this operation completed, it is necessary to check all programming steps.



Info

There are two methods to reset.

6.1.7.1 Partial reset



CAUTION

All the parameters are set to default values, except flow meter totalizer volume in diagnostic mode.

- a) Press and hold and for 25 seconds until the display shows time of day.

```
12:00
```

6.1.7.2 Hard reset



CAUTION

All the parameters are set to default values.

- a) Disconnect the power supply from the valve, press and hold the button while reconnecting the power supply.

6.2 NXT2 Controller

6.2.1 Display

6.2.1.1 During service

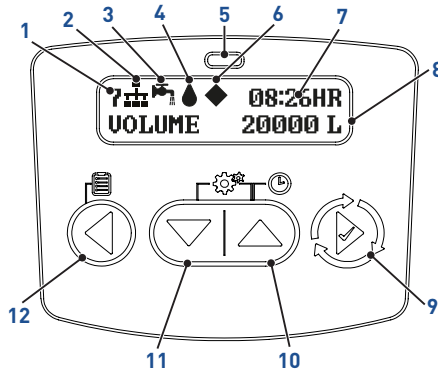











1. System type

- #4: Single valve;
- #5: Multiple valves, parallel interlock system, 2 to 8 valves;
- #6: Multiple valves, parallel series regeneration system, 2 to 8 valves;
- #7: Duplex alternating immediate system, 2 valves;
- #8: Duplex alternating delayed system, 2 valves;
- #9: Multiple valves, parallel system with standby unit, 2 to 8 valves;
- #14: Multiple valves, system on-demand, 2 to 8 valves.

2. Network Indicator

- Connected;
- Disconnected;
- Unit missing;
- USB Connected.

- 3. Valve status
 -  Initializing: after a power failure or a change in the programming, the controllers initializes for approximately 30 seconds;
 -  Lock windows: the controller has acquired the lockout windows;
 -  Lock remote: the controller has acquired the lockout remote;
 -  Regeneration Inhibition indicator: In a multi-valves system, a valves is in regeneration while another valve is waiting for regeneration;
 -  Valve in service;
 -  Flashing: Regeneration queued;
 -  Valve in standby;
 -  Remote Regeneration.
- 4. Flow indicator
 -  Flashing when flow is going through the meter.
- 5. LED Status Indicator
 - Blue: In Service
 - Flashing blue: Regeneration Queued
 - Green: Regeneration
 - Flashing green: Standby
 - Red: Error condition present
 - All LED flashing: Delayed unlock
- 6.
 -  Master unit (auto-assigned) for multi-unit system;
 - Empty for single unit.
- 7. Time of the day
 - 24h mode or 12h am/pm depending on units type selected
- 8. Operating mode
 - Remaining volume in volumetric mode;
 - Remaining days before regeneration in timeclock mode.
- 9. Regen. button
 - Navigate to next menu option
 - Display time of programmed regeneration
- 10. Up button
 - Adjust menu value up
- 11. Down button
 - Adjust menu value down
- 12. Left button
 - Navigate to previous menu option

6.2.2 Commands

6.2.2.1 Menu commands



Info

At any time, press ◀ to return to previous screen without saving.



Info

Menus are displayed in a defined and incremental order.



Info

Editable digit is marked by two triangles (Cursor).

- a) Press ▶ to pass to the next step and save programming.
- b) Use ▶ to move the cursor to the next digit, or use ◀ to move the cursor to the previous digit.
- c) Use ▼ and ▲ to adjust the values.
- d) Press ◀ at any time to return to previous step without saving the current parameters changes.

6.2.2.2 Access commands



Info

Hold pressed 2 seconds the following buttons.

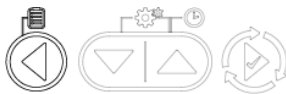

- Enter diagnostic menu

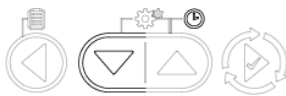

- Enter time of day menu



- Enter time of day menu

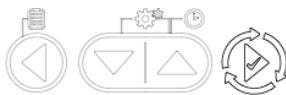

- Initiate an immediate regeneration



- Access to user programming menu

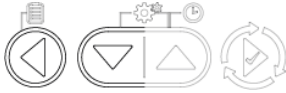

- Access to master programming menu

6.2.3 Time of day menu



Mandatory

In multiple valve systems, set the time of day on the lead valve (#1).



Info

The time of day will be automatically updated on the other valves in the system within 10 seconds.



Info

If, during time setting, no buttons are pushed for 5 minutes, the system leaves the setting menu.

6.2.3.1 Time of day

Set the time in the system.

- Press ▼ or ▲ for 2 seconds.
- Adjust as desired the time with ▼, ▲ and ▶.
- Press ▶ to validate the selection and advance to the next parameter.

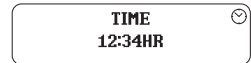

6.2.3.2 Year

Set the year.

- Set the year with ▼ and ▲:
- Press ▶ to validate the selection and advance to the next parameter.

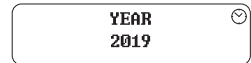

6.2.3.3 Month

Set the month.

- Set the month with ▼ and ▲:
- Press ▶ to validate the selection and advance to the next parameter.



6.2.3.4 Calendar day

Set the day of the month.

- a) Set the day of the month with ▼ and ▲:
- b) Press to validate the selection and advance to the next parameter.



6.2.4 Basic programming



Info

Menus are displayed in a defined and incremental order. Depending of selected system or regeneration type, some of this parameters may not be visible. Editable or selected value or digit is marked by one or two triangles.

6.2.4.1 Basic programming mode chart

Parameter	Options	Definition	Note
DAY OVERRIDE / TIME DRIVEN	OFF to 99	Day	Days between regenerations only for metered regeneration types.
	4, 8, 12, 16, 20	Hour	Hours or days between regenerations only for time clock regeneration type.
	1 to 1999	Day	
REGENERATIO N TIME	00:00 to 23:59	Hour	Regeneration time will not appear when day override/time driver is by hours for time clock or OFF for meter immediate regeneration type.
HARDNESS	1 to 1999	Gram as CaCO ₃ equivalent if hardness unit is mg/L °FTH if hardness unit is °FTH °dH if hardness unit is °dH °eH if hardness unit is °eH	Those screens will only display when regeneration type selected is softener meter immediate or delayed.
VOLUME REMAINING	0 to 4820	Liter	
PUSH SETTINGS	ON	(default)	Only displayed for multi unit systems.
	OFF	-	

6.2.4.2 Day Override / Time-driven

Set the maximum number of days between two regenerations, regardless from the volume of water treated.



Info

For a timeclock valve, this value must be set. For metered valves, calendar override parameter would trigger a regeneration only if the volumetric control did not start a regeneration before calendar override period elapsed. Each volumetric regeneration happening reset the calendar override delay. Calendar override is not visible in «Day of the week» mode.

- a) Press and hold ▼ and ▲ simultaneously to enter user programming mode.
- b) Select the number of days or hours with ▼ and ▲.
- c) Press ▶ to validate the selection and advance to the next parameter.
 - ⇒ Can be adjusted with 4H, 8H, 12H, 16H, 20H or from 1 to 99 days for timeclock regeneration and from OFF to 99 days for metered regeneration.

Without calendar override.

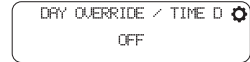

Override every 3 days.

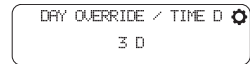

6.2.4.3 Regeneration time

Set the time for regeneration start.



Mandatory

It must be set when the regeneration mode programmed is timeclock, day of week mode, volumetric delayed mode and any time a calendar override period is set.

- a) Adjust the time with ▼ and ▲.
- b) Press ▶ to validate the selection and advance to the next parameter.

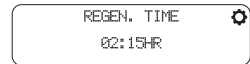

6.2.4.4 Hardness

Set the inlet water hardness in the unit defined on chapter Units [▶ Page 101].



Info

This parameter is not visible in "Filter " mode.

- a) Adjust the hardness with ▼, ▲ and ▶.
- b) Press ▶ to validate the selection and advance to the next parameter.



6.2.4.5 Volume remaining

Display the remaining volume before the system's capacity is exhausted. This parameter can be adjust if necessary, and will be reset to the programmed capacity after next regeneration.



Info

This parameter is visible only in "Softener meter immediate/delayed " mode

- a) Adjust the volume with ▼, ▲ and ▶.
- b) Press ▶ to validate the selection and advance to the next parameter.

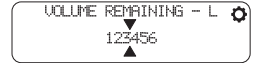

6.2.4.6 Push settings

This parameter allows to push and copy settings from the master unit to all other connected units.



Info

This parameter is visible only in multi-units systems.

- a) Select OFF or ON with ▼ and ▲.
- b) Press ▶ to validate the selection.

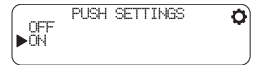

6.2.5 Master programming mode



Info

As soon as programming mode is entered, all parameters can be displayed or set to suit the needs. Depending on the current programming, some functions will not be displayed or will not be changeable.



Info

If none of the buttons are pushed for 5 minutes in the Programming mode, or if there is a power failure, the controller returns to Service mode without saving.



Mandatory

In order to store the new settings in the programming mode, it is necessary to go through all the parameters.

6.2.5.1 Master programming mode chart

Parameter	Options	Definition	Note
SETTINGS REVIEW	ON	-	When settings review mode is on, no programming changes can be done.
	OFF (Default)	-	

Parameter	Options	Definition	Note
LANGUAGE	ENGLISH	English (default)	
	FRANCAIS	French	
	DEUTSCH	German	
	ITALIANO	Italian	
	ESPANOL	Spanish	
	NEDERLANDS	Dutch	
	PORTUGUESES	Portuguese	
ASSISTANCE NAME 1		-	12 characters maximum.
ASSISTANCE NAME 2		-	
ASSISTANCE PHONE		-	14 characters maximum.
SYSTEM TYPE	4	Single unit (default)	1 unit.
	5	Parallel interlock	2 to 8 units.
	6	Parallel series regeneration	
	7	Alternating immediate	2 units.
	8	Alternating delayed	
	9	Parallel with standby unit	2 to 8 units.
	14	On-demand	
NUMBER OF TANKS	2 to 8	Valves in the system	This screen will not be displayed for system type 4, 7 and 8.
TRIP POINT #X - LPM	1 to 7563	l/min	System 14 only.
TRIP POINT #X - SERVICE DURATION	1 to 90	Second	System 14 only; Duration for which the service flow rate must be greater than the above trip point flow rate to cause the next tank to move into service position.
TRIP POINT #X - STANDBY DURATION	60 to 300	Second	System 14 only; Duration for which the service flow rate must become lower than the above trip point flow rate to cause one of the tank of the system to move back into stand-by position.

Parameter	Options	Definition	Note
VALVE	2510	-	Valve type.
	2750	(default)	
	2850	-	
	2900	-	
	3150	-	
	3900	-	
	2815	-	
REGEN. FLOW	DOWN FLOW	Down flow softener (default)	
	UP FLOW	Up flow softener	
	FILTER	Filter	
REGEN. TYPE	TIME CLOCK	Time clock (default)	System 4 and 6 only.
	DAY OF THE WEEK	Regeneration on selected days	System 4 and 6 only.
	METER IMMEDIATE	Metered immediate	All system unless system 8.
	METER DELAYED	Metered delayed	Systems 4, 6 and 8 only.
UNITS	US	US units (default)	
	METRIC	Metric units	
VOL. OVERRIDE/ VOLUMETRIC	0 to 9999999	Liter	This screen will only display when regeneration type selected is filter meter immediate or Delayed.
HARDNESS UNITS	mg/L	mg/L as CaCO ₃ equivalent (default)	This screen will only display when regeneration type selected is softener meter immediate or delayed with metric units.
	*DH	-	
	*FTH	-	
	*EH	-	
CAPACITY	0 to 9999999	Gram as CaCO ₃ equivalent if hardness unit is mg/L L x °FTH if hardness unit is °FTH L x °dH if hardness unit is °dH L x °eH if hardness unit is °eH	Those screens will only display when regeneration type selected is softener meter immediate or delayed.

Parameter	Options	Definition	Note
HARDNESS	1 to 1999	Gram as CaCO ₃ equivalent if hardness unit is mg/L °FTH if hardness unit is °FTH °dH if hardness unit is °dH °eH if hardness unit is °eH	Those screens will only display when regeneration type selected is softener meter immediate or delayed.
RESERVE	WEEKLY RESERVE	(default)	This screen will only display when regeneration type selected is softener meter delayed.
	VARIABLE RESERVE	-	
	FIXED%	-	
	FIXED VOLUME	-	
FIXED%	0 to 50	%	This screen will only display when regeneration type selected is softener meter delayed with fixed% reserve; Any value set above 50% will be discard and 50% will be considered as % reserve.
FIXED VOLUME	0 up to the half of the total capacity	Liter	This screen will only display when regeneration type selected is softener meter delayed with fixed volume reserve; Range depend on capacity value. Any value set above the half of the capacity will be discarded and considered as the half of the capacity.
REMOTE REGENERATION	OFF	(default)	
	IMMEDIATE	-	
	DELAYED	-	
REMOTE SIGNAL DURATION	1 to 5940	Second	Only displayed if immediate or delayed is chosen for remote regeneration.

Parameter	Options	Definition	Note
DAY OF WEEK	SU	Sunday (default)	This screen will only display when regeneration type selected is day of week; Activate or de-activate for each position (X = deactivated; ✓ = activated).
	MO	Monday	
	TU	Tuesday	
	WE	Wednesday	
	TH	Thursday	
	FR	Friday	
	SA	Saturday	
DAY OVERRIDE / TIME DRIVEN	OFF to 99	Day	Days between regenerations only for metered regeneration types.
	4, 8, 12, 16, 20	Hours	Hours or days between regenerations only for time clock regeneration type.
	1 to 99	Day	
REGENERATION TIME	00:00 to 23:59	Hour	Regeneration time will not appear when day override/time driver is by hours for time clock or OFF for meter immediate regeneration type.
LOCK WINDOW #1	ON	-	Period during which no regeneration can start. Maximum 2 lock windows programmable.
	OFF	(default)	
LOCK START #1	00:00 to 23:59	Hour	This screen will only display when lock windows #1 is on.
LOCK END #1	00:00 to 23:59	Hour	This screen will only display when lock windows #1 is on.
LOCK WINDOW #2	ON	-	This screen will only display when lock windows #1 is on.
	OFF	(default)	
LOCK START #2	00:00 to 23:59	Hour	This screen will only display when lock windows #1 and 2 are ON.
LOCK END #2	00:00 to 23:59	Hour	This screen will only display when lock windows #1 and 2 are ON.
BACKWASH	0 to 240	Minute	
DRAW	0 to 240	Minute	Brine draw and slow rinse. This screen will not be displayed for filter systems.
RAPID RINSE	0 to 240	Minute	

Parameter	Options	Definition	Note	
TANK REFILL	0 to 240	Minute	Regenerant tank refill. This screen will not be displayed for filter systems.	
PAUSE	0 to 240	Minute	This screen will not be displayed for filter systems.	
METER TYPE	GENERIC	- (default for 2510)	Default flow meter type is based on the valve type; This screen will only display on the lead (#1) unit for system types 6, 7 & 8.	
	0.75" PADDLE			
	0.75" TURBINE	-	All other system types it will display for all units; This screen will only display when regeneration type selected is softener meter immediate or delayed.	
	1.0" PADDLE	(default for 2750)		
	1.0" TURBINE	-		
	1.25" TURBINE	-		
	1.5" PADDLE	(default for 2815 and 2850)		
	1.5" TURBINE	-		
	2.0" PADDLE	(default for 2910 and 3150)		
	3.0" PADDLE	(default for 3900)		
PULSES/L	0 to 1500	PULSES/L		Only displayed if "Generic" is chosen for the meter type.
MAXIMUM FLOW - LPM	76 to 7570	l/min		
CONTINUOUS FLOW DETECT	ON	-	This screen will only display when regeneration type selected is softener meter immediate or delayed.	
	OFF	(default)		
CONTINUOUS FLOW DETECT - FLOW RATE- LPM	0.1 to 227.1	l/min	Only displayed if continuous flow detect is ON. Even if maximum theoretical programmable value is 999.9 l/min, the controller will consider only up to 227.1 l/min.	
CONTINUOUS FLOW DETECT - DURATION	1 to 255	Hour	Only displayed if continuous flow detect is ON.	

Parameter	Options	Definition	Note
AUXILIARY 1	STANDBY		Activates relay from beginning of regeneration and during standby phase.
	OFF	(default)	
	ALARM BASED	-	Any alarm or error detected by the controller will start signal output from Auxiliary relay#1.
	CYCLE BASED	-	
	TIME BASED	-	
	VOLUME BASED	-	This choice will only available when metered regeneration type.
AUX. 1: CYCLE BASED	SP	Service position	Only displayed if "Cycle based" is chosen for auxiliary 1; Activate or de-activate for each position (X = deactivated; ✓ = activated).
	BW	Backwash position	
	BD	Draw and slow rinse position	
	RR	Rapid rinse position	
	RF	Refill position	
	SB	Pause position	
AUX. 1: TIME BASED - START TIME #1	0 to total regeneration time minus 1 minute	Minute	Only displayed if "Time based" is chosen for auxiliary 1.
AUX. 1: TIME BASED - END TIME #1	from start time#1 plus 1 minute until total regeneration duration	Minute	
AUX. 1: TIME BASED - START TIME #2	OFF End time #1 to total regeneration duration minus 1 minute	Minute	Only displayed if "Time based" is chosen for auxiliary 1 and END TIME #1 < total regeneration duration minus 1 minute; Range depend on Start and end time #1 values.

Parameter	Options	Definition	Note
AUX. 1: TIME BASED - END TIME #2	OFF From start time #2 + 1 minute until the total regeneration duration	Minute	Only displayed if "Time based" is chosen for auxiliary 1 and START TIME #2 ON; Range depends on Start and end time #1 values.
AUX. 1: VOLUME BASED - VOLUME - L	0 to MAX	Liter	Only displayed if "volume based" is chosen for auxiliary 1; Volume range depend on capacity; Even if maximum theoretical programmable value is 999999 the controller will take the unit capacity as maximum volume.
AUX. 1: VOLUME BASED - DURATION	1 to 7200	Second	Only displayed if "volume based" is chosen for auxiliary 1; Volume range depend on capacity; Even if maximum theoretical programmable value is 9999 the controller will take 7200 as duration.
AUXILIARY 2	STANDBY		Activates relay from beginning of regeneration and during standby phase.
	OFF	(default)	
	ALARM BASED	-	Any alarm or error detected by the controller will start signal output from Auxiliary relay#2.
	CYCLE BASED	-	
	TIME BASED	-	
	VOLUME BASED	-	This choice will only available when metered regeneration type.

Parameter	Options	Definition	Note
AUX. 2: CYCLE BASED	SP	Service position	Only displayed if "Cycle based" is chosen for auxiliary 2; Activate or de-activate for each position (✗ = deactivated; ✓ = activated).
	BW	Backwash position	
	BD	Draw and slow rinse position	
	RR	Rapid rinse position	
	RF	Refill position	
	SB	Pause position	
AUX. 2: TIME BASED - START TIME #1	0 to total regeneration time minus 1 minute	Minute	Only displayed if "Time based" is chosen for auxiliary 2.
AUX. 2: TIME BASED - END TIME #1	from start time#1 plus 1 minute until total regeneration duration	Minute	
AUX. 2: TIME BASED - START TIME #2	OFF End time #1 to total regeneration duration minus 1 minute	Minute	Only displayed if "Time based" is chosen for auxiliary 2 and END TIME #1 < total regeneration duration minus 1 minute; Range depend on Start and end time #1 values.
AUX. 2: TIME BASED - END TIME #2	OFF From start time #2 + 1 minute until the total regeneration duration	Minute	Only displayed if "Time based" is chosen for auxiliary 2 and START TIME #2 ON; Range depend on Start and end time #1 values.
AUX. 2: VOLUME BASED - VOLUME - L	0 to MAX	Liter	Only displayed if "volume based" is chosen for auxiliary 1; Volume range depend on capacity; Even if maximum theoretical programmable value is 999999 the controller will take the unit capacity as maximum volume.

Parameter	Options	Definition	Note
AUX. 2: VOLUME BASED - DURATION	1 to 7200	Second	Only displayed if "volume based" is chosen for auxiliary 1; Volume range depend on capacity; Even if maximum theoretical programmable value is 9999 the controller will take 7200 as duration.
PUSH SETTINGS	ON	(default)	Only displayed for multi unit systems.
	OFF	-	
SAVE AS NON- FACTORY	ON	-	The non-factory configuration can be used on RESET.
	OFF	(default)	
LOCK SETTINGS	OFF	(default)	Lock setting prevents unexpected access to master programming.
	DELAYED	-	
	ENTER CODE	-	
	TIME BASED	-	

6.2.5.2 Entering master programming mode

- a) Press and hold and simultaneously for two seconds to enter the master programming mode;
- b) Set the password using , and ;
 - ⇒ If the controller calls for a Password that is unknown to you, please contact your installer.

If lock settings is activated.



6.2.5.3 Settings review

Activate or deactivate the settings review mode.

Options:

- on: all parameters and current programming can be displayed but not modified;
- off: all parameters are displayed and programmable.

- a) Adjust the time with and .
- b) Press to validate the selection and advance to the next parameter.

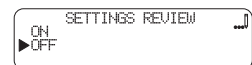

6.2.5.4 Language setting

Select the displayed language.

Options:

- English;
- French;
- German;
- Italian;
- Spanish;
- Dutch;
- Portuguese.

a) Select the system type with ▼ and ▲;

b) Press ▶ to validate the selection and advance to the next parameter.



6.2.5.5 Assistance name 1 and 2

Edit names of assistance.



Info

Maximum 12 characters per screen.



Tip

Press the ▶ button for 2 seconds to go immediately to next screen.

a) Edit assistance name using ▼, ▲ and ▶;

- ⇒ Assistance name is empty by default;
- ⇒ Each character can be chose from A to Z or stay empty;

b) Press ▶ to validate the selection and advance to the next parameter.



6.2.5.6 Assistance phone

Edit phone number.



Info

Maximum 14 digits.



Tip

Press the ▶ button for 2 seconds to go immediately to next screen.

- a) Edit assistance phone using ▼, ▲ and ▶;
 - ⇒ Assistance phone is empty by default;
 - ⇒ Each character can be chose from 1 to 9 or stay empty;
- b) Press ▶ to validate the selection and advance to the next parameter.



6.2.5.7 System type

Select the system in which the valve(s) operate(s).

Options:

- 4: single valve;
- 5: multiple valves, parallel interlock system (2- 8 units);
- 6: multiple valves, parallel series regeneration system (2- 8 units);
- 7: duplex alternating immediate system (2 units);
- 8: duplex alternating delayed system (2 units);
- 9: multiple valves, parallel system with standby unit (2- 8 units);
- 14: multiple valves, system on-demand (2- 8 units).

- a) Select the system type with ▼ and ▲;
 - ⇒ Default system: system 4;
- b) Press ▶ to validate the selection and advance to the next parameter.

Example: 4 Single valve.

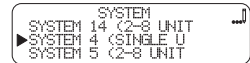

Example: 5 multiple valves.

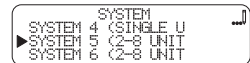

6.2.5.8 Number of tanks

Set the number of valves to be connected (2 to 8 valves) in the system.



Info

Only visible in multiple valve systems and only present on the master valve.

Options:

- 2 to 8 valves in the system.
- a) Select number of tanks with ▼ and ▲;
 - ⇒ Default setting: 2 valves;
 - b) Press ▶ to validate the selection and advance to the next parameter.

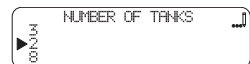

6.2.5.9 Trip points setting

Set the flow rate and switching service and standby duration.



Info

Only visible in system 14.















Info

Visible only on master valve, identified by  on the controller screen.



Info

Depending on the number of tank used in the system, there might up to 7 trip point to set up (for 8 tanks systems). Each additional trip point might be set for a flow rate equal to the previous one plus 1 l/min.

- a) Set the trip point flow rate with ,  and ;
 - ⇒ Can be adjusted from 1 to 7569 l/min;
- b) Press  to validate the selection and advance to the next parameter;
- c) Set the trip point service duration with ,  and ;
 - ⇒ Can be adjusted from 1 to 90 seconds;
- d) Press  to validate the selection and advance to the next parameter;
- e) Set the trip point service standby with ,  and ;
 - ⇒ Can be adjusted from 60 to 300 seconds;
- f) Press  to validate the selection and advance to the next parameter.

Example: trip point #1.

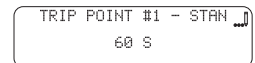
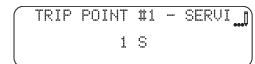

6.2.5.10 Valve type

Select which valve is being used with the NXT2.

Options:

- 2510
- 2750;
- 2850;
- 2900/2910;
- 3150;
- 3900;
- 2815.

- a) Set valve type at 3150 with ▼ and ▲;
- b) Default setting: 2750;
- c) Press ▶ to validate the selection and advance to the next parameter.

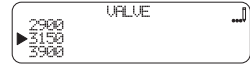

6.2.5.11 Regeneration flow

Set the direction of flow during the brine draw cycle for softener, or set filter.

Options:

- down flow;
- up flow (do not use for 2510 and 2850 valve types);
- filter.

- a) Set regeneration flow with ▼ and ▲;
⇒ Default setting: down flow;
- b) Press ▶ to validate the selection and advance to the next parameter.

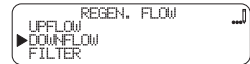

6.2.5.12 Regeneration type

Select the regeneration type.



Info

This screen will display for system 4 and 6.

For all other systems the regeneration type is defined by default: meter delayed for system 8 and meter immediate for system 5, 7, 9 and 14.



Info

The availability depends on regeneration flow (softener or filter) type programmed in the previous step.

Options:

- time clock: The unit will regenerate at the preset regeneration time once the preset interval between two regeneration elapsed;
- day of the week: The unit will regenerate on preset day(s) of the week at the preset regeneration time;
- softener or filter meter delayed: When volume remaining reaches zero and the scheduled regeneration time is reached (default 2 a.m. softener; 12 a.m. filter), the unit will regenerate;
- softener or filter meter immediate: When volume remaining reaches zero, the unit will regenerate.

a) Set regeneration type with ▼ and ▲;

⇒ Default regen. type: time clock;



b) Press ▶ to validate the selection and advance to the next parameter.

6.2.5.13 Units

Set the unit system to be used.

Options:

- US: volume in gallons, time display 2 x 12 hours, hardness in grains;
- metric: volume in liter, time display 24 hours and hardness depends on hardness unit set (see Hardness units [▶ Page 101])

a) Set the unit system with ▼ and ▲;

⇒ Default system unit: US;

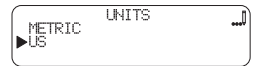

b) Press ▶ to validate the selection and advance to the next parameter.

6.2.5.14 Volume override/ Volumetric

Set the volume of water between 2 cleaning/regeneration cycles.



Info

Available only for filter metered systems.

a) Set the volume override with ▼, ▲ and ▶;

⇒ Can be adjusted from 0 to 9'999'999 liter;

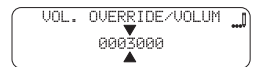

b) Press ▶ to validate the selection and advance to the next parameter.

6.2.5.15 Hardness units

Set hardness unit system to be used.



Info

This screen is displayed only if units mode programmed is metric (Units [▶ Page 101]).



Info

1°F = 10 mg/L CaCO₃ = 10ppm CaCO₃ = 0.56°dH = 0.7 °eH

Options:

- mg/L;
- °DH: German;

- °FTH: French;
 - °EH: English.
- a) Set hardness unit with ▼ and ▲;
- ⇒ Default metric hardness unit: mg/L;

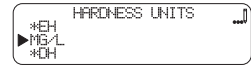

- b) Press ► to validate the selection and advance to the next parameter.

6.2.5.16 Capacity

Set the capacity of the tank where the valve is installed.



Info

Available only for softening metered systems.



Info

Based upon the system capacity, safety coefficient and inlet water hardness, the controller calculates the volume of water that the system can treat between 2 regenerations.



Info

When hardness unit is programmed in mg/L as CaCO₃, the capacity must be programmed in grams as CaCO₃ equivalent and correspond to the total equivalent mass of CaCO₃ that the system can treat before requiring regeneration.

When the hardness unit is programmed in °FTH, °dH or °EH, the capacity must be programmed in liter and correspond to the total volume of water the system could treat if the inlet water hardness was 1° in the corresponding unit before requiring regeneration.

- a) Set the capacity with ▼, ▲ and ►;
- b) Can be adjusted from 0 to 9.999.999 grams;
- c) Press ► to validate the selection and advance to the next parameter.

Example: 3000 g of CaCO₃ of capacity.

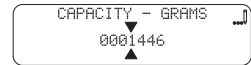

6.2.5.17 Hardness

Set the inlet water hardness in the unit set on chapter Hardness units [►Page 101]

a) Set hardness with ▼ and ▲;

⇒ Can be adjusted from:

⇒ 1 - 1999 mg/l;

⇒ 1- 199 °F;

⇒ 1 - 112.0 °dH;

⇒ 1 - 140.2 °eH.

⇒ Any value programmed above the maximum value for each unit will be discarded and considered as the maximum above mentioned value for the relevant unit.



b) Press ▶ to validate the selection and advance to the next parameter.

6.2.5.18 Reserve

Set the reserve type.



Info

Available only for softening metered systems.

Options:

- weekly reserve;
- variable reserve;
- fixed%;
- fixed volume.

a) Select reserve type with ▼ and ▲;

b) Press ▶ to validate the selection and advance to the next parameter.



Fixed%

Set the percentage of the total unit capacity used to calculate the unit safety reserve capacity.



Info

The availability depends on reserve type programmed in the previous step.

- a) Set the safety coefficient with ▼, ▲ and ▶;
- ⇒ Can be adjusted from 0 to 50%;
 - ⇒ Any value programmed above the maximum value will be discarded and considered as the maximum above mentioned value.
- b) Press ▶ to validate the selection and advance to the next parameter.

No safety factor programmed.



Fixed volume

Set a fixed volume as safety reserve capacity.



Info

The availability depends on reserve type programmed in the previous step.

- a) Set the reserve volume with ▼, ▲ and ▶;
- ⇒ The volume range depend on capacity, in liter if metric units were programmed or US gallon if US units were programmed [see Units ▶ Page 101] ;
 - ⇒ The maximum reserve volume capacity settable will correspond to the half of the total volume.
- b) Press ▶ to validate the selection and advance to the next parameter.



6.2.5.19 Remote regeneration

Set the regeneration type for remotely started regeneration (external dry contact input, see chapter Electrical connections ▶ Page 52)].



Info

This mode can be combined with the other methods of regeneration; the remotely started regenerations overrule the other regeneration type once the signal is acquired.

Options:

- off;
- immediate;
- delayed.

- a) Set the remote regeneration mode with ▼ and ▲;
- ⇒ Default setting: off;
- b) Press ▶ to validate the selection and advance to the next parameter.

Remote regeneration deactivated.

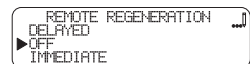

6.2.5.20 Remote signal duration

Set remote signal duration.



Info

The availability depends on remote regeneration option programmed in the previous step.



Info

The contact will close after a preset signal duration. When the contact closes, remote regeneration signal is acquired and a regeneration will start (immediate or delayed) as programmed in Remote regeneration [▶ Page 104].

- a) Set the signal duration with ▼ and ▲;
 ⇒ Can be adjusted from 1 to 5940 seconds;
- b) Press ▶ to validate the selection and advance to the next parameter.



6.2.5.21 Day of the week

Select the day of the week of regeneration.



Info

Available only for day of the week regeneration type.

Options:

- Sunday;
- Monday;
- Tuesday;
- Wednesday;
- Thursday;
- Friday;
- Saturday.

- a) Select the days for regeneration with ▼ and ▲;
 ⇒ Default setting: Sunday;
 ⇒ Multi-selection is possible;
 ⇒ Not selected days are marked by X and selected days are marked by ✓;
- b) Press ▶ to validate the selection and advance to the next parameter.

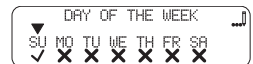

6.2.5.22 Day override/time driven

Set the maximum number of days between two regenerations regardless from any other regeneration triggering type that could be programmed.



Info

For a timeclock valve, this value must be set as regeneration period in hours or days.



Info

For metered valves, this value can be set in days only.



Info

Not available if the regeneration type programmed is Day of week mode.

- a) Adjust the number of days with ▼ and ▲;
 ⇒ Can be adjusted with 4H, 8H, 12H, 16H, 20H or from 1 to 99 days for timeclock regeneration and from OFF to 99 days for metered regeneration;

Calendar override deactivated.

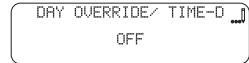

- b) Press ► to validate the selection and advance to the next parameter.

Override every 3 days.

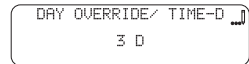

6.2.5.23 Regeneration time

Set the time for regeneration start.



Info

Depending on regeneration mode programmed, this parameter may be displayed or not.

- a) Adjust the time of regeneration with ▼, ▲ and ►;
- b) Can be adjusted from: 00:00 to 23:59HR;
- c) Press ► to validate the selection and advance to the next parameter.

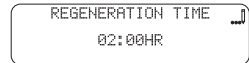

6.2.5.24 Lock setting

Set Lock Window settings: Enable lock windows then select the desired Lock Start time and Lock End time.



Info

Lock Window prevents the unit from regenerating during a specified time frame. Two lock windows are available (Lock Window #1 and Lock Window #2).



Mandatory

Before deactivating lock window #1, you must deactivate lock window #2 first, otherwise lock window #2 will remain active but not visible anymore in the programming.

Lock window #1

Set Lock Window #1 settings.

- a) Enable lock window with ▼ and ▲;
⇒ Default setting: off;
- b) Press ▶ to validate the selection and advance to the next parameter.
- c) Set lock start time with ▼ and ▲;
- d) Press ▶ to validate the selection and advance to the next parameter.
- e) Set lock end time with ▼ and ▲;
- f) Press ▶ to validate the selection and advance to the next parameter.

Lock window #1 activated.

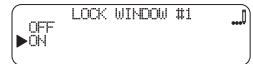

Lock window #1 starts at 12:00.

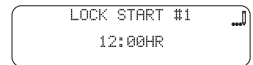

Lock window #1 ends at 13:00.

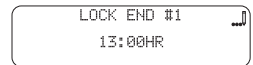

Lock window #2

Set Lock Window #2 settings.



Info

Lock Window #2 settings are accessible only if lock windows #1 is on.

- a) Enable lock window with ▼ and ▲;
⇒ Default setting: off;
- b) Press ▶ to validate the selection and advance to the next parameter.
- c) Set lock start time with ▼ and ▲;
- d) Press ▶ to validate the selection and advance to the next parameter;
- e) Set lock end time with ▼ and ▲;
- f) Press ▶ to validate the selection and advance to the next parameter.

Lock window #2 activated.



Lock window #2 starts at 13:00.



Lock window #2 ends at 14:00.

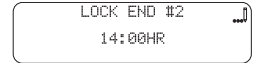

6.2.5.25 Programming regeneration cycles time

Set the regeneration cycles duration in minutes.



Info

A maximum of 5 cycles can be programmed.



Info

For filter system only backwash and rapid rinse are available.



Info

The sequence of the regeneration cycles depends upon regenerant flow, see System regeneration cycle [» Page 20].

- a) Adjust the cycle time with ▼ and ▲;
 ⇨ Can be adjusted from: 0 to 240 minutes;
- b) Press ▶ to validate the selection and advance to the next parameter;
- c) Repeat for each cycle.

1. Backwash: 10 min.

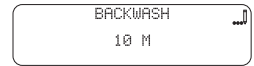

2. Draw: 60 min.

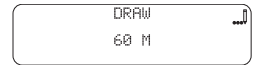

3. Rapid rinse: 10 min.

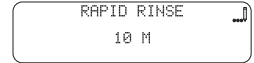

4. Tank Refill: 12 min.

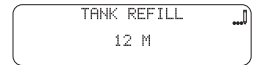

5. Pause: not used.

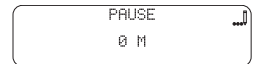

6.2.5.26 Meter type

Select the size of the flow meter.



Info

Available only for softening metered systems.

Options:

- 0.75" paddle (standard for 2510 valve series);
- 0.75" turbine;
- 1.0" paddle (standard for 2750 valve series);
- 1.0" turbine;
- 1.25" turbine;
- 1.5" paddle (standard for 2815 and 2850 valve series);
- 1.5" turbine;
- 2.0" paddle (standard for 2900 and 3150 valve series);
- 3.0" paddle (standard for 3900 valve series);
- generic.

- a) Select the meter type with ▼ and ▲;
- b) Press ▶ to validate the selection and advance to the next parameter.

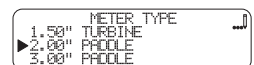

Generic meter

Set the generic meter settings.



Info

Only visible if "generic" was selected as meter type in the previous step.



Info

This parameter has two settings. First enter the number of pulses per 1 unit of volume, then the maximum expected flow rate.

- a) Set the number of pulses per liter with ▼, ▲ and ▶;
- b) Can be adjusted from: 0 to 1500 Pulses/L;
- c) Press ▶ to validate the selection and advance to the next parameter;
- d) Set the maximum flow with ▼, ▲ and ▶;
- e) Can be adjusted from: 67 to 7570 l/min;
- f) Press ▶ to validate the selection and advance to the next parameter.

Example: 1 pulse per 1L.



Example: 2000 l/min.



6.2.5.27 Continuous flow detect settings

Set continuous flow detect.



Info

Alert appears when specified continuous flow rate is detected during service over a specified duration.



Info

Available only for softening metered systems.



Info

This parameter has three settings: The first one enables or disables continuous flow detection option. If activated, then 2 step will call for flow rate until which a permanent flow could be considered as a leak, the 3rd step will call for programming the period as of which a flow rate lower or equal to the setting in step 2 is considered as a leak and therefore causes the alarm display on the screen.



Info

Note that flow rate observed due to leaks are generally much smaller than service flow rate and this parameter must therefore be programmed accordingly.

Options:

- on;

- off.
- a) Set continuous flow on with ▼ and ▲;
- b) Default setting: off;
- c) Press ▶ to validate the selection and advance to the next parameter;
- d) Adjust flow rate with ▼, ▲ and ▶;
- e) Can be adjusted from: 0.1 to 227.1 l/min;
- f) Press ▶ to validate the selection and advance to the next parameter;
- g) Adjust duration with ▼ and ▲;
- h) Can be adjusted from: 1 to 255 Hours;
- i) Press ▶ to validate the selection and advance to the next parameter.

Continuous flow detect activated.



Continuous flow detect - Flow rate 0.1 l/min.

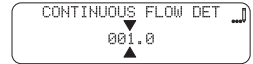

Continuous flow detect - Duration 8H.

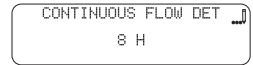

6.2.5.28 Auxiliary Relays settings

Program auxiliary output relays (dry contact). To locate the relays on the board, see AUX 1 and AUX 2 at NXT2 controller connections [▶ Page 54].



Info

The NXT2 has two auxiliary relays available based on alarm, cycle, time or volume. The following settings are auxiliary 1 settings and are the same for auxiliary 2.

Options:

- standby (activates relay from beginning of regeneration and during standby phase);
- off;
- alarm based;
- cycle based;
- time based;
- volume based.

- a) Choose the options of relay with ▼ and ▲;
- b) Default setting: disabled;
- c) Press ▶ to validate the selection and advance to the next parameter.

Disabled.

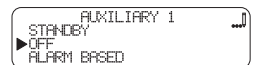

Cycle based

Set the cycle based relay output during regeneration.



Info

Only visible if "cycle based" was selected as auxiliary in the previous step.

- a) Choose the options of relay with ▼ and ▲;
 - ⇒ Unselected cycle are marked by ✕;
 - ⇒ Activated cycles are marked with a ✓;
 - ⇒ Multi-selection is possible;

Activated during selected cycle step.

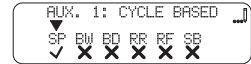

- b) Press ► to validate the selection and advance to the next parameter.

Time based

Set the time based relay output during regeneration.



Info

Only visible if "time based" was selected as auxiliary in the previous step.



Info

This parameter has two steps of settings for each time Start time # / End time#. The first one activates the relay output, and the second one deactivates the relay output. The time 0 MIN corresponds to the beginning of regeneration time. If the first interval of activation does not cover the whole regeneration duration, it is possible to set up a second interval.

- a) Set the relay Start time #1 with ▼ and ▲;
- b) Can be adjusted from:0 to the total regeneration duration minus 1 minute;
- c) Press ► to validate the selection and advance to the next parameter.
- d) Set the relay End time #1 with ▼ and ▲;
- e) Can be adjusted from: start time #1 + 1 to the total regeneration time, in minutes;
- f) Should the End time#1 be shorter than the total regeneration duration, a second interval may be programmable in the remaining period of regeneration, provide this remaining period is long enough to allow activation/deactivation of the relay (minimum 2 minutes are required).
- g) Press ► to validate the selection and advance to the next parameter;

Activated as of the regeneration starts.

TIME BASED - START TIME #1.

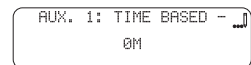

Deactivated 10 minutes after the regeneration started.

TIME BASED - END TIME #1.

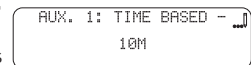

- a) Set the relay Start time #2 with ▼ and ▲;
- b) Can be adjusted from: end time #1 +1 to the total regeneration duration minus 1 minute;
- c) Press ▶ to validate the selection and advance to the next parameter;
- d) Set the relay End time #2 with ▼ and ▲;
- e) Can be adjusted from: start time #2 + 1 to the total regeneration duration;
- f) Press ▶ to validate the selection and advance to the next parameter.

Activated 12 minutes after the regeneration started.

TIME BASED - START TIME #2.

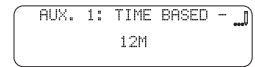

Deactivated 150 minutes after the regeneration started.

TIME BASED - END TIME #2.

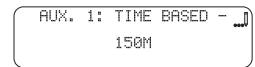

Volume based (Chemical pump)

Activate the relay output during the service for a preset duration based upon the volume of treated water.



Info

Only visible if "volume based" was selected as auxiliary in the previous step.



Info

Only visible in metered systems.



Info

This parameter has two steps. The first one determines the volume which activates the relay. The second one determines how long the relay has to be activated once the volume has passed.

- a) Set the relay activation volume with ▼ and ▲;
- b) Can be adjusted from: 1L to the total capacity of a service cycle excluding the reserve capacity.;
- c) Press ▶ to validate the selection and advance to the next parameter;
- d) Set the relay activation duration with ▼ and ▲;
- e) Can be adjusted from: 1 to 7200 seconds;
- f) Press ▶ to validate the selection and advance to the next parameter.

Activates upon 1 L.

VOLUMEBASED-VOLUME-L.



Deactivates upon 10 minute.

VOLUMEBASED-DURATION-S.



6.2.5.29 Push settings

Select the desired Master Programming settings on one unit then push the same settings to all other connected units.



Info

Available only for multi-valves systems.



Info

The ability to transmit settings from one unit to all other connected units. After push settings are complete, you may still make unique changes to individual units.

Options:

- off;
- on.

a) Select the push settings with ▼ and ▲;

b) Default setting: enabled;

c) Press ▶ to validate the selection and advance to the next parameter.

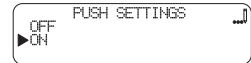

6.2.5.30 Save as non-factory



Info

Parameters set on master programming menu can be saved as a non-factory program. This saved program will be restorable from the reset menu.

Options:

- off;
- on.

a) Select save as non-factory option with ▼ and ▲;

b) Default setting: disabled;

c) Press ▶ to validate the selection and advance to the next parameter.

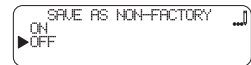

6.2.5.31 Lock settings

Select the desired lock settings option (off, time based, delayed, or enter code).



Info

Lock Settings prevents unexpected access to master programming.



Info

Once lock settings option is activated, the controller returns to normal service display. The next time accessing the menu, the controller will call for either a password, or will grant access to menu only if programmed condition are fulfilled.



Info

Contact your supplier for more information.

Options:

- off;
- delayed;
- enter Code;
- time Based.

a) Select save as non-factory option with ▼ and ▲;

b) Default setting: disabled;

c) Press ▶ to validate the selection.



6.2.5.32 Parameters saving



Info

When the last parameter is set and the button ▶ pressed (after lock settings), the controller updates the database based on the new programming.



Info

The main screen appears and valve status is initializing. Wait until updating is finished, this may take a few seconds.

6.2.6 Diagnostic



Info





Depending on current settings, some displays cannot be viewed.



Info

If none of the buttons are pushed for 5 minutes in the Programming mode, or if there is a power failure, the controller returns to Service mode without saving.

6.2.6.1 Commands

- a) Press and hold  to enter the Diagnostic mode.
- b) Press  to see the next data group or press  to return to previous data group.
- c) Press and hold  to exit the Diagnostic mode at any time.

6.2.6.2 Flow rate



Info

The display is updated every second.

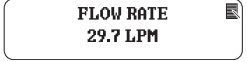

FLOW RATE
29.7 LPM

6.2.6.3 Peak flow rate



Info

The controller registers the highest flow rate since the last regeneration.





PEAK FLOW
30.1 LPM

6.2.6.4 Totalizer



Info

The controller registers the total volume of treated water that passes through the meter since start-up (or last hard reset).

- a) To reset, press and hold the buttons  and  for 5 seconds until the display shows zero.



TOTALIZER
123 L

6.2.6.5 Reserve



Info

Shows the reserve capacity settings.



RESERVE
12 L

6.2.6.6 Use since regeneration



Info

Shows the volume at the outlet since last regeneration

USE SINCE REGEN
4 L

6.2.6.7 Valve address



Info

Shows the position of the valve in a multiple valve system.

ADDRESS
1

6.2.6.8 Last regeneration



Info

Shows the number of hours since the last regeneration, indicating the duration of the current service cycle.

LAST REGEN.
4H

6.2.6.9 Software version



Info

Shows the version of the software loaded in the controller.



Mandatory

In case of use of multiple valves system, verify the controller's software compatibility.

SOFTWARE VERSIO
1.0.1387

6.2.6.10 Number of regeneration



Info

Shows number of regeneration since installation.

NO. OF REGENS
2

6.2.6.11 Regeneration interval



Info

Shows duration between regenerations.

REGEN. INTERVAL
5 D 0 H

6.2.6.12 Last settings change



Info

Shows when the last settings change occurred.

LAST SETTINGS CH
1H

6.2.6.13 Error log



Info

The last 20 error or alarm events are registered showing time and date of occurrences.

ERROR LOG
#20-2019-04-17 09:
#1-2019-04-18 10:4
#2-2019-04-18 10:4

6.2.6.14 Sunday average daily usage



Info

Shows average water consumption on Sunday.

SUN - AVERAGE DAI
29 L

6.2.6.15 Sunday- daily usage



Info

Shows water consumption for the last 20 Sunday.

```
SUN - DAILY USAGE
2019-03-30 0 L
▶ 2019-04-12 0 L
2019-04-10 0 L
```

6.2.6.16 Monday average daily usage



Info

Shows average water consumption on Monday.

```
MON - AVERAGE DAI
29 L
```

6.2.6.17 Monday- daily usage



Info

Shows water consumption for the last 20 Monday.

```
MON - DAILY USAGE
2019-03-31 0 L
▶ 2019-04-15 0 L
2019-04-11 0 L
```

6.2.6.18 Tuesday average daily usage



Info

Shows average water consumption on Tuesday.

```
TUE - AVERAGE DAI
29 L
```

6.2.6.19 Tuesday- daily usage



Info

Shows water consumption for the last 20 Tuesday.

```
TUE - DAILY USAGE
2019-04-01 0 L
▶ 2019-04-14 0 L
2019-04-12 0 L
```

6.2.6.20 Wednesday average daily usage



Info

Shows average water consumption on Wednesday.

WED - AVERAGE DAI
29 L

6.2.6.21 Wednesday- daily usage



Info

Shows water consumption for the last 20 Wednesday.

WED - DAILY USAGE
2019-04-02 0 L
▶ 2019-04-15 0 L
2019-04-13 0 L

6.2.6.22 Thursday average daily usage



Info

Shows average water consumption on Thursday.

THU - AVERAGE DAI
29 L

6.2.6.23 Thursday- daily usage



Info

Shows water consumption for the last 20 Thursday.

THU - DAILY USAGE
2019-04-03 0 L
▶ 2019-04-16 0 L
2019-04-14 0 L

6.2.6.24 Friday average daily usage



Info

Shows average water consumption on Friday.

FRI - AVERAGE DAI
29 L

6.2.6.25 Friday- daily usage



Info

Shows water consumption for the last 20 Friday.

```

FRI - DAILY USAGE
2019-04-04 0 L
▶ 2019-04-17 0 L
2019-04-15 0 L
    
```

6.2.6.26 Saturday average daily usage



Info

Shows average water consumption on Saturday.

```

SAT - AVERAGE DAI
29 L
    
```

6.2.6.27 Saturday- daily usage



Info

Shows water consumption for the last 20 Saturday.

```

SAT - DAILY USAGE
2019-04-05 0 L
▶ 2019-04-18 0 L
2019-04-16 0 L
    
```

6.2.7 Resetting the controller



Mandatory

Once you have completed this operation, it is necessary to check all programming steps.



Info

There are two options to reset: reset to factory defaults or reset to Non-Factory Defaults.







CAUTION

Reset to factory defaults: All the parameters are set to factory default values.

Reset to non-factory defaults: All the parameters are set to previously saved default values.

Options:

- back: acces to main screen without resetting;
- reset to factory defaults;
- reset to non-factory defaults.

- a) Power on the unit;
- b) When Pentair's logo appears, press and hold ;
 - ⇒ The Reset menu appears;
- c) Select reset option with  and ;
 - ⇒ Default setting: reset to factory defaults;
- d) Press  to validate the selection.

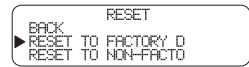

7 Commissioning



Info

This chapter is available for standard regeneration types. Contact your supplier if the actual regeneration is not standard and if you need assistance.

7.1 Water filling, draining and waterproofness inspection

7.1.1 Activating a single valve system (System #4)

- a) With the bypass still in Bypass position (inlet and outlet of the valve closed), plug in the NXT/NXT2 controller to the power source.
- b) Proceed to programming according to system specification if not done yet.
- c) Start a manual regeneration by pressing the regen button for 5 seconds. The piston will move into backwash position. Once in this position, unplug the NXT/NXT2 controller from the power source.
- d) With the outlet manual valve still closed, slowly open the inlet manual valve. The valve and tank will slowly get filled with raw water, allowing air to be purged by the drain. Open the inlet let progressively until fully open position.
- e) Once the drain runs clear and the inlet manual valve fully open, plug in again the NXT/NXT2 controller to the power source.
- f) Push on the regen button once to move the piston to the next regeneration cycle position. Leave the valve 1 minute in each position and move to the next one, until C4 or Cycle 4/5 is displayed. When C4 or Cycle 4/5 is displayed, let the valve run the entire cycle and check the level of water in the brine tank. The level of water in the brine tank should be about 5 cm above the salt platform. You may want to mark the level on the brine tank as this can be used as an indicator for the future lifetime of the softener.
- g) Once C5 or Cycle 5/5 is completed, the valve will automatically go back into service position (unless non-standard regen sequence is programmed). Start again a manual regeneration by pressing for 5 seconds on the regen button. The valve will move to backwash position.
- h) Press the regen button once to move to brine draw position. Check to see in the brine tank if the water level decreases.
- i) Once the draw function is observed and confirmed (level of water in the brine tank has decreased), you may go through each cycle pushing on the regen button until C5 or Cycle 5/5, leave the water come back to the 'full' level, and then push on the regen button so that the valve returns into service position.
- j) Slowly open the outlet manual valve, and close the bypass manual valve. The system is now in service.
- k) Fill the brine tank with salt. You may want to mark the level of water in the brine tank when completely refilled with water and full of salt. In the future, after each regeneration, you can visually control that the quantity of water refilled should be between the 2 marks done. Marking are optional, but may allow to visually detect a irregularity during regeneration that may lead to softener inefficiency.

- l) With the brine tank completely refilled and full of salt, adjust the safety brine valve in the brine well. Make sure the overflow elbow is installed above the float level and the discharge point.
- m) After the softener has been running a few minutes in service, proceed to hardness test on outlet water to make sure the water is treated as per requirements.

7.1.2 Activating a multiple valves system (Systems #5, #6, #7, #8, #9 and #14)

- a) Follow the previous procedure for each tank of the system.



Info

In order to save time, program first all tanks as single system #4. Proceed to start up as described above for each tank, then program the correct system type and valve addresses (NXT only, NXT2 featuring automatic valve addressing) and eventually set/trip points in case of system #14.

7.1.2.1 Triplex and quadruplex system

After start up is complete and system is synchronized according to the system type program, adjust manually the tanks remaining capacities per tank in the diagnostic mode. If the capacity of all tanks in service are equal after start up, then the system could show the unwanted situation where several tanks are fully exhausted at the same time, leading to uncertain treated water quality for a short period. This can be avoided by manually balancing the capacities of the different tanks at start up. Note that this operation may require to be done regularly during normal service life of the system.

Example:

Assuming a triplex system #5 or #9. The valve with address #1, is set capacity at 50% of its real capacity in the diagnostic mode. The valve with address #2 is set it at 75% and the valve with address #3 is left at the real capacity. (Depending on the resin volume, you may also choose to balance on 33%, 66% and 100%). The tanks in service will reach exhausted state at different moment.

Once regenerated, each tank will restart its cycle with 100% of its capacity as programmed.

The capacity adjustment in the diagnostic mode is valid only for the current cycle, it does not affect not modify the programmed system capacity.

7.2 Sanitization

7.2.1 Disinfection of water softeners

The materials of construction of the modern water softener will not support bacterial growth, nor will these materials contaminate a water supply. In addition, during normal use, a softener may become polluted with organic matter, or in some cases with bacteria from the water supply. This may result in an off-taste or odour in the water.

Thus, your softener may need to be disinfected after installation. Some softeners will require periodic disinfection during their normal lifetime. Consult your installing dealer for more information on disinfecting your softener.

Depending on the conditions of use, the softener type, the type of ion exchanger and the disinfectant available, a choice can be made among the following methods.

7.2.2 Sodium or calcium hypochlorite

These materials are satisfactory for use with polystyrene resins, synthetic gel zeolite, greensand and bentonites.

5.25% Sodium hypochlorite

If stronger solutions are used, such as those sold for commercial laundries, adjust the dosage accordingly.

Dosage

Polystyrene resin: set 1.25 mL fluid per 1 L of resin.

Non-resinous exchangers: set 0.85 mL fluid per 1 L.

Brine tank softeners

Backwash the softener and add the required amount of hypochlorite solution to the well of the brine tank. The brine tank should have water in it to permit the solution to be carried into the softener.

Proceed with the normal regeneration.

Calcium hypochlorite

Calcium hypochlorite, 70% available chlorine, is available in several forms including tablets and granules. These solid materials may be used directly without dissolving before use.

Do not let the disinfectant stand for more than 3 hours in the brine tank before the regeneration start.

Dosage

Measure two grains ~ 0.11 mL for 1 L.

Brine tank softeners

Backwash the softener and add the required amount of hypochlorite to the well of the brine tank. The brine tank should have water in it to permit the chlorine solution to be carried into the softener.

Proceed with the normal regeneration.

7.2.3 Electro chlorination

Valves or systems already equipped with an electrochlorinator device or system will be sanitized during the brine draw phase.

8 Operation

8.1 Display

8.1.1 NXT controller

8.1.1.1 During service

- Single valve in service in timeclock mode:

4#- SRV	15:25HR
REGEN EN	03 DAYS
- single valve in service in volume immediate or delayed mode:

4#- SRV*	14:24HR
VOLUME	8000L
- lead valve in regeneration queued in interlock system:

5#1 SRV*	10:15HR
VOLUME	25000L
- valve 3 in service in serial regeneration system:

6#3 SRV*	08:42HR
SYSVOL	45000L

8.1.1.2 During regeneration

During regeneration the display shows the cycle number and the time remaining for that cycle. The countdown for the time remaining starts only when the valve is in the cycle displayed.

- Cycle 1, time remaining 10 min:

CYCLE 1	00:10:00
---------	----------
- cycle 2, time remaining 1 hour 20 min:

CYCLE 2	01:20:00
---------	----------
- cycle 3, time remaining 50 min:

CYCLE 3	00:50:00
---------	----------
- cycle 4, time remaining 2 hours 40 min:

CYCLE 4	02:40:00
---------	----------
- cycle 5, time remaining 15 min:

CYCLE 5	00:15:00
---------	----------



8.1.2 NXT2 controller

8.1.2.1 During service

- Single valve in service in timeclock mode:







4	🔌	12:00HR
REGEN IN		4 D
- single valve in service in volume immediate or delayed mode:

4	🔌	12:00HR
FLOW		10.2 LPM

- lead valve in regeneration queued in interlock system: 
- window lock activated in serial regeneration system: 
- remote lock activated in serial regeneration system: 

8.1.2.2 During regeneration

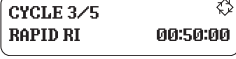
During regeneration the display shows the cycle number and the time remaining for that cycle. The countdown for the time remaining starts only when the valve is in the cycle displayed.

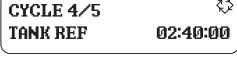
- The timer advance to regeneration cycle step #1:  During transition to cycle:
- cycle step #1, time remaining 10 min:  Once in position:
- the timer advance to regeneration cycle step #2:  During transition to cycle:
- cycle step #2, time remaining 1 hour 20 min:  Once in position:
- the timer advance to regeneration cycle step #3:  During transition to cycle:
- cycle step #3, time remaining 50 min:  Once in position:
- the timer advance to regeneration cycle step #4:  During transition to cycle:
- cycle step #4, time remaining 2 hours 40 min:  Once in position:

- the timer advance to regeneration cycle step #5:

During transition to cycle:



- cycle step #5, time remaining 15 min:

Once in position:



8.1.3 LED status

- Blue → the unit is in service and no errors detected;
- Blue flashing → the unit is in service with a queued regeneration;
- Green → the unit is in regeneration;
- Green flashing → the unit is in standby position, in a multi tank system;
- Red → the controllers have detected an error;
- All LED flashing → delayed unlock, only forNXT2.

8.2 Recommendations

- Use only regeneration salts designed for water softening in accordance with EN973;
- for optimal system operation, the use of clean salt, free from impurities, is recommended (for example salt pellets);
- do not use ice melt, block, or rock salts;
- the sanitizing process (both with liquid and electrochlorination) may introduce chlorine compounds which may reduce the lifetime of the ion exchange resins. Refer to the technical guides for resins in common use, providing necessary checks on the system.

8.3 Manual regeneration



Mandatory



The controller must be in service in order to enable this procedure.

8.3.1 Manual delayed regeneration



- Press (for NXT) or (for NXT2) once for delayed regeneration.
 - ⇒ The regeneration starts on the programmed regeneration time. See chapter Regeneration start time [▶ Page 74] for NXT and chapter Regeneration time [▶ Page 106] for NXT2;
 - ⇒ For NXT: The blue LED flashes and the letters RGQ take place on the valve state;
 - ⇒ For NXT2: The blue LED and the symbol on the valve state flash.





Info

To cancel: press  (for NXT) or  (for NXT2) again;
 For NXT: The blue LED stop flashing and the letters SRV take place on the valve status;
 For NXT2: The blue LED and the symbol  stop flashing.

8.3.2 Immediate regeneration

- a) Press and hold  (for NXT) or  (for NXT2) for 5 seconds to initiate immediate manual regeneration, regardless from the programmed regeneration mode.

8.3.3 To advance regeneration cycles

- a) Press  (for NXT) or  (for NXT2) to pass to the next regeneration cycle.

8.3.4 To stop a regeneration (NXT2 only)

- a) Press and hold  to stop the regeneration.

8.4 Operation during a power failure

- All the program settings are stored in a permanent memory;
- current valve position, cycle step time elapsed, and time of day are stored during a power failure, and will be restored upon power restoration;
- time is kept during a power failure and the time of day is adjusted upon restoration of the power (as long as the power is restored within 12 hours);
- the time of day on the main display screen will flash after a power failure once the power is restored until any button is pressed on the keyboard.

9 Maintenance



Mandatory

Cleaning and maintenance shall take place at regular intervals in order to guarantee the proper functioning of the complete system, and be documented in the Maintenance chapter in the User Guide document.



Mandatory

The maintenance and service operation must be done by qualified personnel only. Failure in respecting this may void the warranty !

9.1 General system inspection



Info

Has to be done once a year at minimum.

9.1.1 Water quality

9.1.1.1 Valve used for softening

- a) Raw water total hardness.
- b) Treated water hardness.

9.1.1.2 Valve used for filtration

- a) Check for raw water analysis and filter's targeted contaminants concentration.
- b) Check for treated water analysis and compare with raw water data.

9.1.2 Mechanical Checks

- a) Inspect general condition of softener/filter and associated ancillaries and check for any leaks, ensure valve connection to piping is made with adequate flexibility as per manufacturer instruction.
- b) Inspection of electrical connections, verify wiring connections and search for evidence of overloading.
- c) Verify settings of electronic timer, verify regeneration frequency, and make sure the valve configuration is appropriate for media and tank size.
- d) Check water meter, if present, report water meter settings and compare with previous inspection.
- e) If water meter is present, verify total water consumption compared to previous visit.

- f) If pressure gauges are installed before and after softening/filtering system, verify and record static and dynamic pressure, reporting pressure drop. Verify that inlet pressure respects valve and softening/filtering system limits. Verify that pressure drop stay stable year on year, adapt backwash duration if required.
- g) If pressure gauges are not present, but suitable points exist, install temporary pressure gauge(s) to perform point f.

9.1.3 Regeneration test

9.1.3.1 Valve used for softening

- a) Check condition of brine tank and any associated equipment.
- b) Check salt level in brine tank.
- c) Initiate regeneration test.
 - ⇒ Check brine draw during brine draw stage.
 - ⇒ Check brine tank refill.
 - ⇒ Check operation of safety brine valve, where fitted.
 - ⇒ Check for brine draw off levels.
 - ⇒ Check for resin loss at the drain during regeneration.
 - ⇒ Where fitted, check for satisfactory operation of solenoid, i.e. outlet shut off during regeneration and/or brine line shut off valve(s).
- d) Test and record Total Hardness of outlet water from softener vessel(s).

9.1.3.2 Valve used for filtration

- a) Initiate manual regeneration and observe flow to drain.
- b) Make sure flow rate correspond to DLFC configuration.
- c) Check for media loss at the drain during backwash.
- d) Check to see if water runs clear at the end of the backwash cycle.
- e) Observe flow fast rinse cycle and measure pressure drop through the filter system. Pressure drop after fast rinse should return equal or very close to pressure drop recorded after system start-up.
- f) Where fitted, check for satisfactory operation of solenoid valve(s) i.e. outlet shut off during regeneration.

9.2 Recommended maintenance plan

9.2.1 Valve used for softening

Items	1 year	2 year	3 year	4 year	5 year
Injector & filter	Clean	Clean	Clean	Clean	Clean/ replace if necessary
BLFC***	Clean	Clean	Clean	Clean	Clean/ replace if necessary
DLFC***	Clean	Clean	Clean	Clean	Clean/ replace if necessary
Piston*	Check/clean/ replace if necessary	Replace	Check/clean/ replace if necessary	Replace	Check/clean/ replace if necessary
Seals & spacers*	Check/clean/ replace if necessary	Replace	Check/clean/ replace if necessary	Replace	Check/clean/ replace if necessary
Brine valve	Check/clean/ replace if necessary	Check/clean/ replace if necessary	Check/clean/ replace if necessary	Check/clean/ replace if necessary	Replace
O-rings***	Check for watertightne ss /clean or replace in case of leakage	Check for watertightne ss /clean or replace in case of leakage	Check for watertightne ss /clean or replace in case of leakage	Check for watertightne ss /clean or replace in case of leakage	Check for watertightne ss /clean or replace in case of leakage
Motors	Check	Check	Check	Check	Replace
Gearing	Check	Check	Check	Check	Check/ replace if necessary
Inlet hardness	Check	Check	Check	Check	Check
Residual hardness	Check/adapt mixing screw if necessary	Check/adapt mixing screw if necessary	Check/adapt mixing screw if necessary	Check/adapt mixing screw if necessary	Check/adapt mixing screw if necessary
Electronic/ settings**	Check	Check	Check	Check	Check/ replace if necessary
Transformer **	Check	Check	Check	Check	Check/ replace if necessary
Microswitche s	Check	Check	Check	Check	Replace

Items	1 year	2 year	3 year	4 year	5 year
Meter(s)* (if present)	Check and Clean	Check and Clean	Check and Clean	Check and Clean	Replace
Meter cable(s)* (if present)	Check	Check	Check	Check	Replace
Valve watertightne ss	Check	Check	Check	Check	Check
Valve to piping watertightne ss	Check	Check	Check	Check	Check

* Wear parts - durability strongly affected by raw water quality and regeneration frequency.

** Electronic parts – durability strongly affected by power source quality and stability.

*** Elastomer durability is strongly affected by raw water concentration in chlorine and its derivative.

9.2.2 Valve used for filtration

Items	1 year	2 year	3 year	4 year	5 year
DLFC***	Clean	Clean	Clean	Clean	Clean/ replace if necessary
Piston*	Replace	Replace	Replace	Replace	Replace
Seals & spacers*	Replace	Replace	Replace	Replace	Replace
O-rings***	Check for watertightness /clean or replace in case of leakage	Check for watertightness /clean or replace in case of leakage	Check for watertightness /clean or replace in case of leakage	Check for watertightness /clean or replace in case of leakage	Check for watertightness /clean or replace in case of leakage
Motors	Check	Check	Check	Check	Replace
Gearing	Check	Check	Check	Check	Check/ replace if necessary
Electronic/ settings**	Check	Check	Check	Check	Check/ replace if necessary
Transformer **	Check	Check	Check	Check	Check/ replace if necessary
Microswitches	Check	Check	Check	Check	Replace
Meter(s)* (if present)	Check and Clean	Check and Clean	Check and Clean	Check and Clean	Replace
Meter cable(s)* (if present)	Check	Check	Check	Check	Replace
Valve watertightness	Check	Check	Check	Check	Check
Valve to piping watertightness	Check	Check	Check	Check	Check

* Wear parts - durability strongly affected by raw water quality and regeneration frequency.

** Electronic parts – durability strongly affected by power source quality and stability.

*** Elastomer durability is strongly affected by raw water concentration in chlorine and its derivative.

9.3 Recommendations

9.3.1 Use original spare parts



CAUTION

To ensure correct operation and safety of the device, only use original spare parts and accessories recommended by the manufacturer.

Usage of non-genuine spare parts void all warranties.

Parts to keep in stock for potential replacements are the pistons, S&S kit, injectors, micro-switches and motors. Refer to maintenance sheet.

9.3.2 Use original approved lubricants

- Dow Corning #7 Release Agent.

9.3.3 Maintenance instructions

- Disinfect and clean the system at least once a year or if the treated water has an off-taste or an unusual odor;
- perform a hardness test every year of both inlet and treated water.

9.4 Cleaning and maintenance

9.4.1 First steps

Before any cleaning or maintenance procedure, complete the following steps:



CAUTION

These operations need to be performed before any cleaning or maintenance procedure.

- Unplug the wall-mounted transformer.
- Shut off water supply or put bypass valve(s) into bypass position.
- Relieve system pressure before performing any operations.

9.4.2 Power head motor replacement

9.4.2.1 Valve with NXT controller



Info

As the DC motor is equipped with an AC to DC converter, AC and DC motors can be used with the NXT controller.

- a) Using a flat screwdriver, unscrew **(1)** and open the cover **(2)**.
- b) Disconnect the motor **(9)**.
- c) Remove the micro-switches **(10)**, see Micro-switches replacement [► Page 145].
- d) Using a Philips screwdriver, unscrew **(5)** and open the controller **(8)**.
- e) Using pliers, remove the retaining clip **(3)** and the circlip **(6)**.
- f) Remove the pin **(4)** and the plate **(7)**.
- g) Using pliers, remove the circlip **(14)** and the wheel **(13)**.
- h) Using a flat screwdriver unscrew **(12)**.
- i) Using a wrench, unscrew **(11)** and remove the motor **(9)**.
- j) Reverse above procedure steps to rebuild

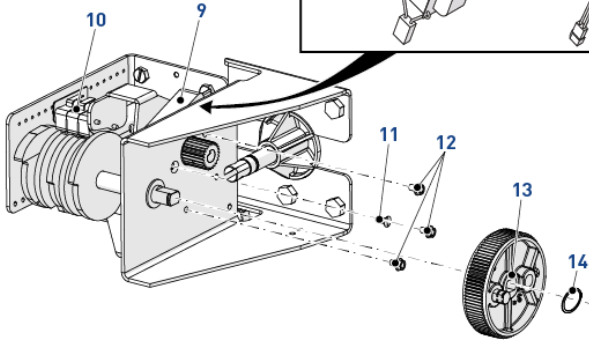
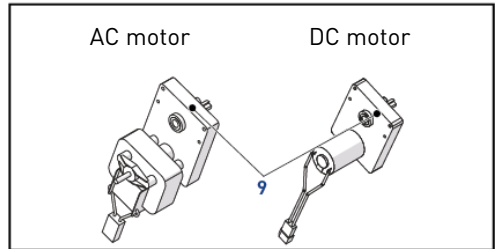
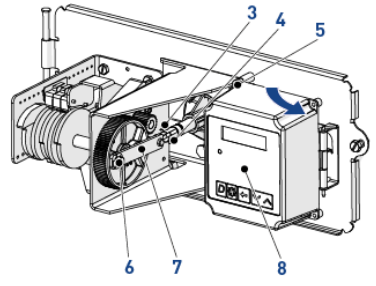
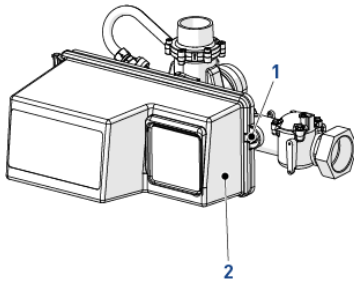

9.4.2.2 Valve with NXT2 controller



CAUTION

Use only DC motor with NXT2 controller.

- a) Using a flat screwdriver, unscrew **(1)** and open the cover **(2)**.
- b) Disconnect the motor **(8)**.
- c) Remove the micro-switches **(9)**, see Micro-switches replacement [►Page 145].
- d) Open the controller **(7)**.
- e) Using pliers, remove the retaining clip **(3)** and the circlip **(5)**.
- f) Remove the pin **(4)** and the plate **(6)**.
- g) Using pliers, remove the circlip **(13)** and the wheel **(12)**.
- h) Using a flat screwdriver unscrew **(11)**.
- i) Using a wrench, unscrew **(10)** and remove the motor **(8)**.
- j) Reverse above procedure steps to rebuild

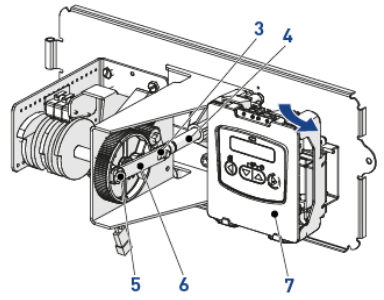
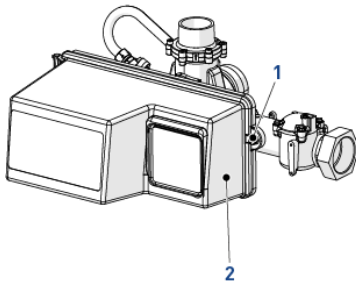

DC motor

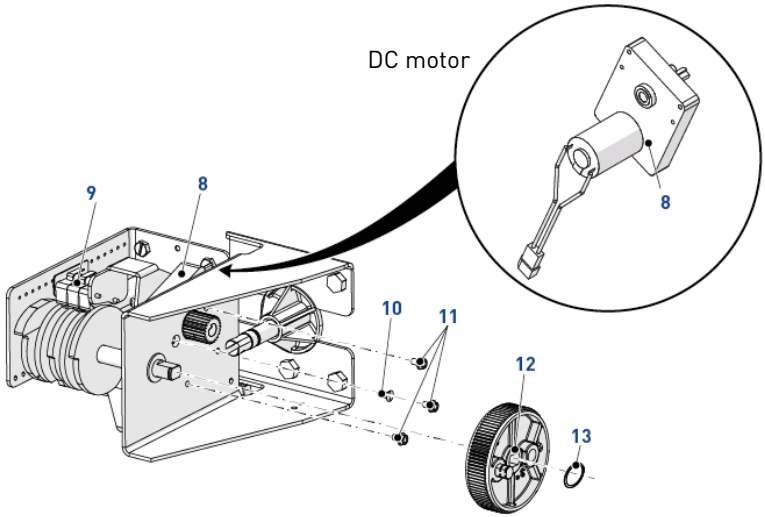

9.4.3 NXT to NXT2 controller upgrade



Mandatory

As NXT2 controller functions only with DC motors, in case of NXT to NXT2 controller upgrade, the AC motor must be changed for a DC motor.

- a) Using a flat screwdriver, unscrew (1) and open the cover (2).
- b) Using a flat screwdriver, unscrew (5) and open the NXT controller (8).
- c) Disconnect the AC motor (9).
- d) Remove the pin (16), the O-ring (18) and the NXT controller (8).
- e) Remove the micro-switches (11), see Micro-switches replacement [► Page 145].
- f) Using pliers, remove the retaining clip (3) and the circlip (6).
- g) Remove the pin (4) and the plate (7).
- h) Using pliers, remove the circlip (15) and the wheel (14).
- i) Using a flat screwdriver unscrew (12).
- j) Using a wrench, unscrew (13) and remove the AC motor (9).
- k) Fit the DC motor (10) in place and using a screwdriver screw (12).
- l) Using a wrench, screw (13).
- m) Fit the wheel (14) in place and fix the circlip (15) using pliers.
- n) Fit the plate (7) with the pin (4) in place.
- o) Using pliers, fix the retaining clip (3) and the circlip (6).
- p) Fit the micro-switches (11) in place, see Micro-switches replacement [► Page 145].
- q) Using the pin (16) and the O-ring (18) fit the NXT2 controller holder (17) in place.
- r) Connect the NXT2 controller (19), see NXT2 controller connections [► Page 54].
- s) Clip the NXT2 controller (19) in the controller holder (17).
- t) Close the NXT2 controller (19).
- u) Close the cover (2) and using a flat screwdriver screw (1).

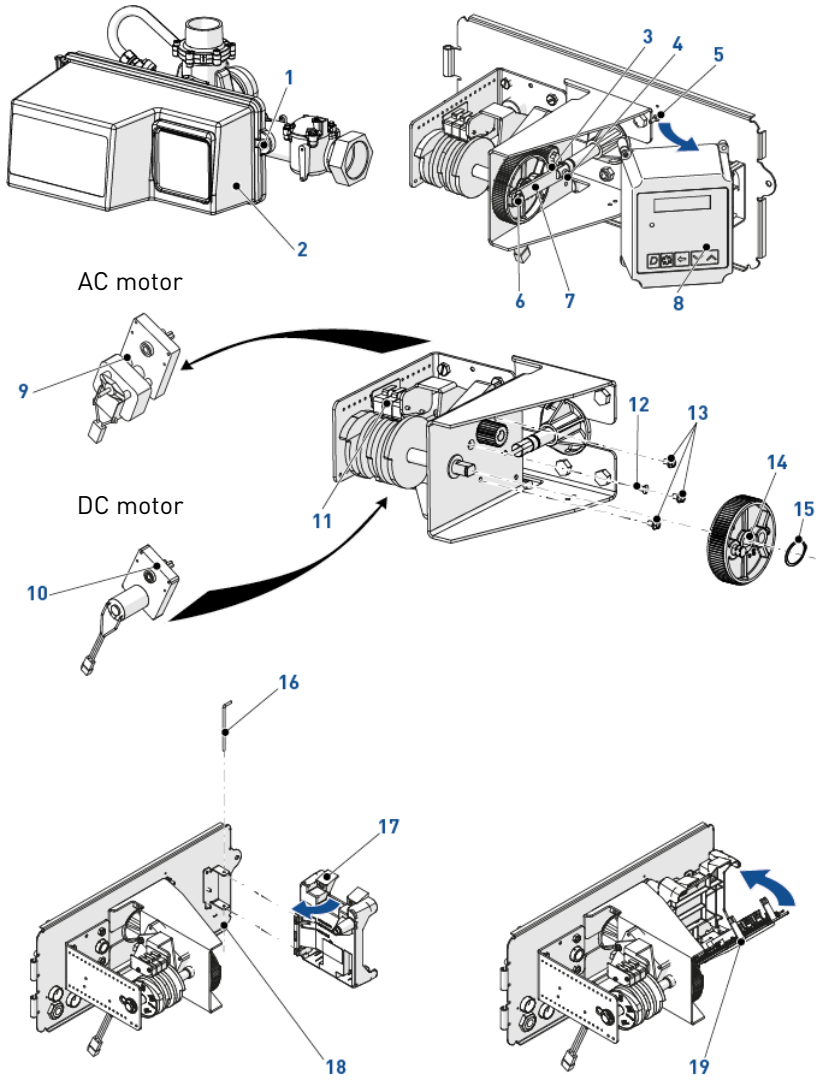

9.4.4 NXT2 controller replacement

- a) Using a flat screwdriver, unscrew (1) and open the cover (2).
- b) Press on the clips (3) and remove the controller (4).
- c) Disconnect the controller (4).
- d) Connect the new NXT2 controller (5), see NXT2 controller connections [▶ Page 54].
- e) Clip the new NXT2 controller (5) in the controller holder (6).
- f) Close the cover (2) and using a flat screwdriver (1).

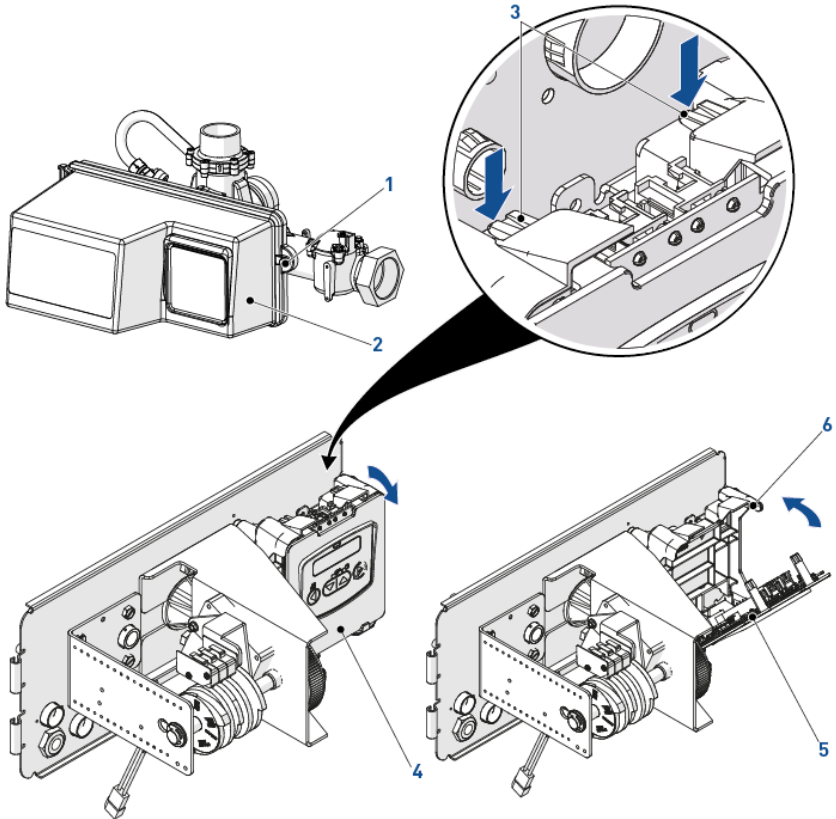

9.4.5 Power head, piston and/or seal and spacer kit disassembly/replacement

- a) Using a flat screwdriver, unscrew (1) and open the cover (2).
- b) Using pliers, remove the clip (6) and the connecting pin (7).
- c) Using a 32 mm wrench, unscrew (3).
- d) Using a 10 mm wrench, unscrew (4) and remove the power head (5).
- e) Using pliers, remove the piston (10).
- f) Using a small hook, remove a seal (12).
- g) Using the puller, remove a spacer (8 or 9).
- h) Repeat the two previous steps for all the seals and spacers.
- i) Lubricate each new seals (12).
- j) Put back a seal (12) using the stuffer.
- k) Put back a spacer (8 or 9) using the stuffer.



Mandatory

Respect the order of the spacers shown on the sketch.

- l) Repeat the two previous steps for all the seals and spacers.
- m) Lubricate the piston o-ring (11).
- n) Put back the piston (10).
- o) Follow the procedure four first steps in reverse order to rebuild.



CAUTION

Use only approved silicone grease or soapy water.

9.4.5.1 Special tools needed

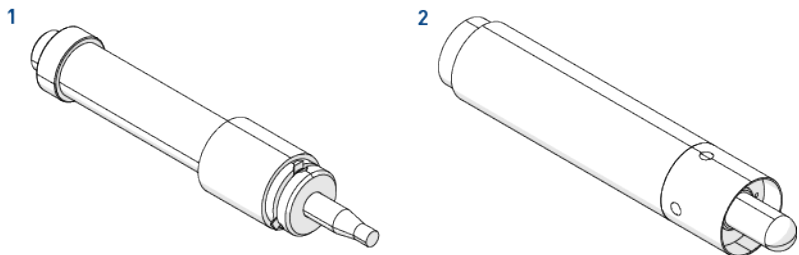

Item	Part number	Description	Packaging quantity
1	12682	Puller	1
2	12683	Stuffer	1

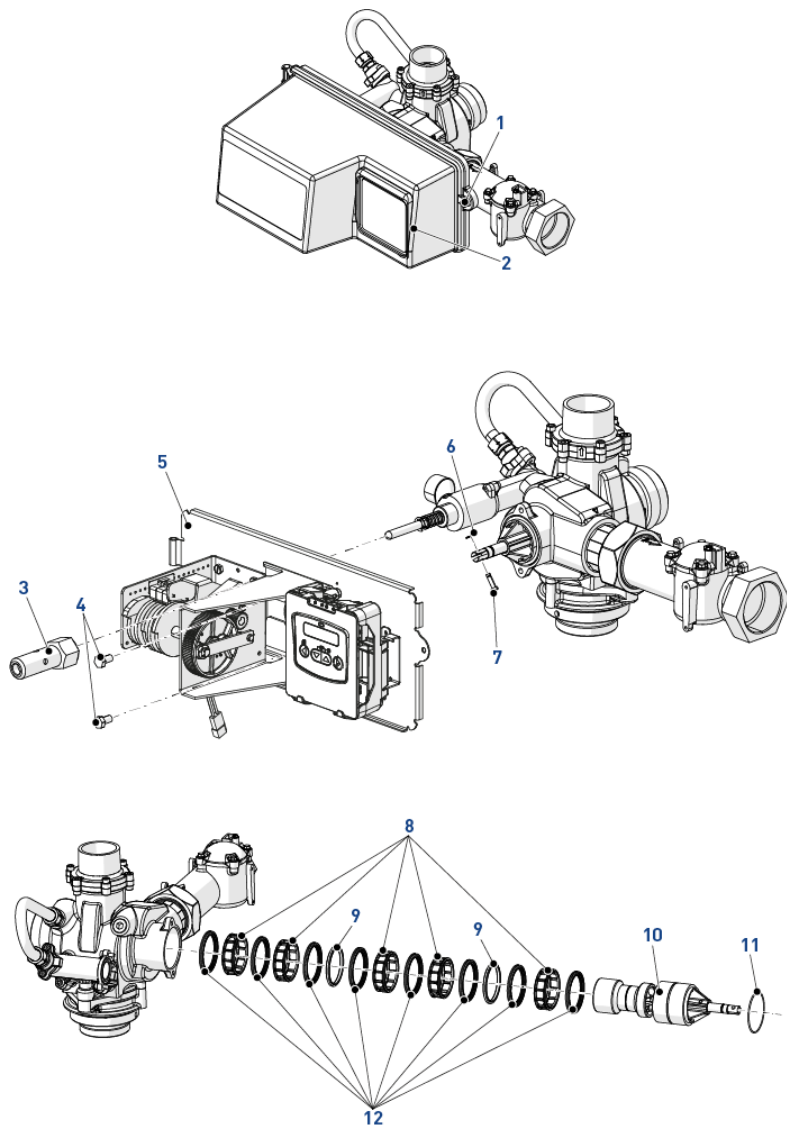

9.4.6 Micro-switches replacement

- a) Using a flat screwdriver, unscrew (1) and open the cover (2).
- b) Using a Phillips screwdriver, unscrew (3) and extract the protection plates (4) and the micro-switches (5).
- c) Reverse above procedure steps to rebuild.

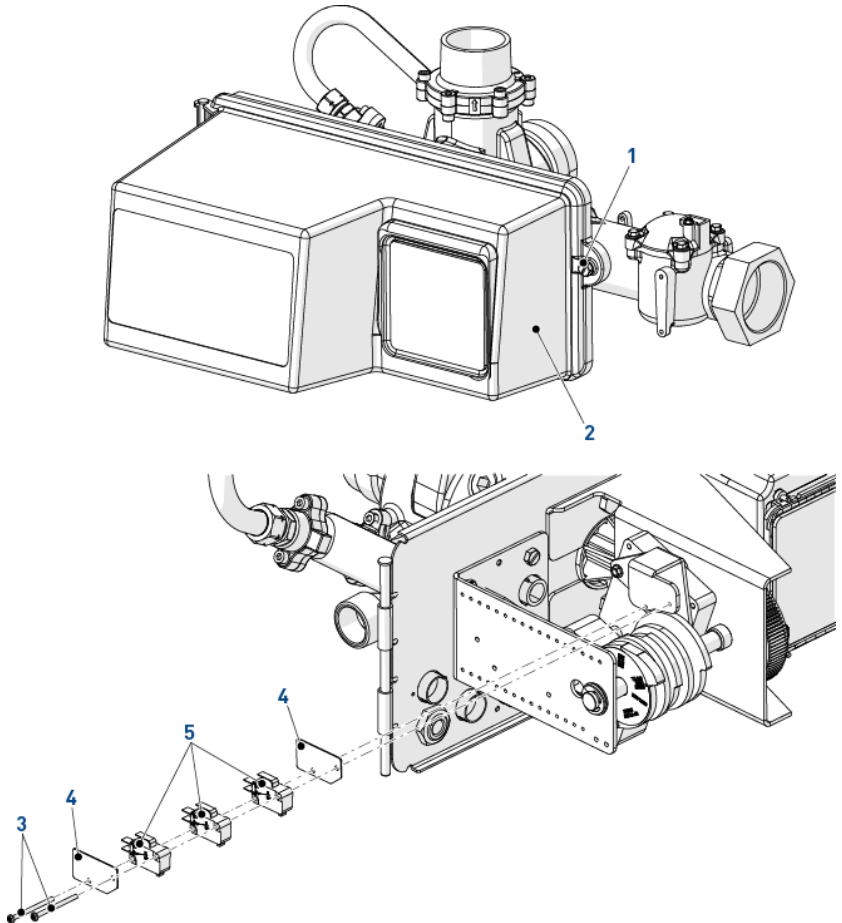

9.4.7 Cams replacement

- a) Using a flat screwdriver, unscrew (1) and open the cover (2).
- b) Remove the micro-switches (3), see Micro-switches replacement [▶ Page 145].
- c) Disconnect the motor (4).
- d) Using a Philips screwdriver, open the controller (7).
- e) Using pliers, remove the clip (5) and the connecting pin (6).
- f) Using pliers, remove the circlip (12) and the wheel (11).
- g) Using a 10 mm wrench, unscrew (9) and remove the plate (10) and the camshaft (8).
- h) Using a pin punch, remove the pin (13).
- i) Reverse above procedure steps to rebuild.

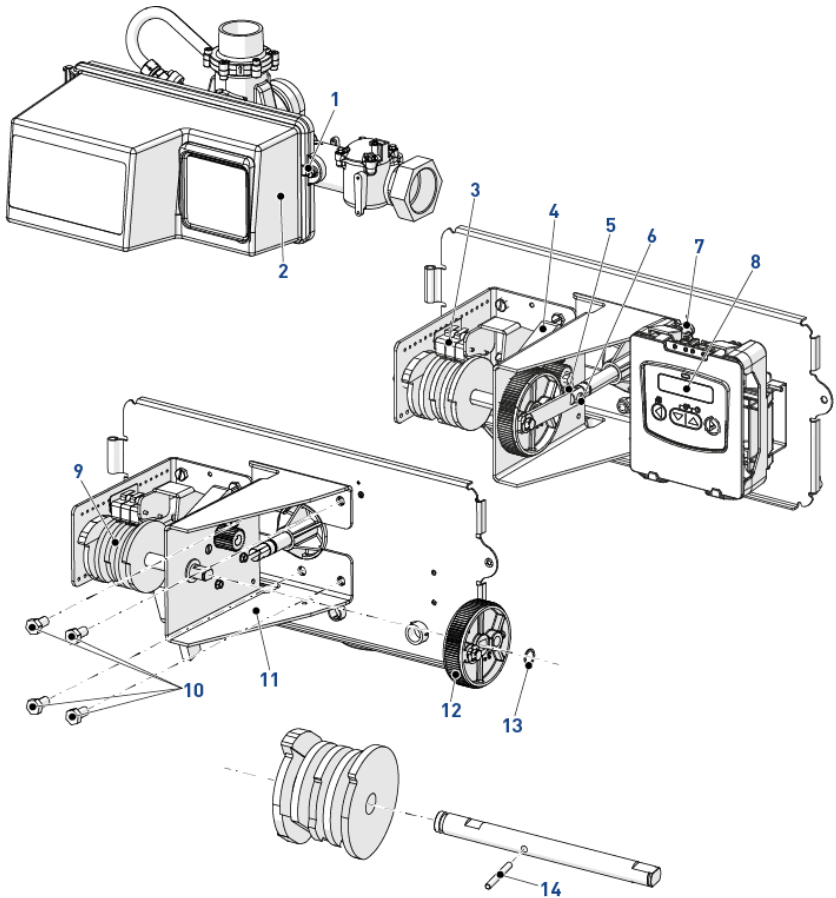

9.4.8 Injector throat and washer cleaning

- a) Using a 4 mm Allen wrench, unscrew (1).
- b) Using a 24 mm wrench, remove the tube (10).
- c) Using a 4 mm Allen wrench, unscrew (11) and remove the connector (9), the o-ring (8) and the injector nozzle (7).
- d) Using a 4 mm Allen wrench, unscrew (5) and remove the T-tube (6), the o-rings (3 and 12), the injector throat (4) and the injector washer (2).
- e) Clean the injector throat (4) and the injector washer (2) using compressed air, a soft brush or possibly a pin.
- f) Lubricate on the o-rings (3), (8) and (12) using silicone grease.
- g) Reverse above procedure steps to rebuild.



Mandatory

The injector washers (2) have to be installed with their chamfered side upfront the water stream flow. Flow indication must be visible after the injector washer (2) is placed on the seat (4).

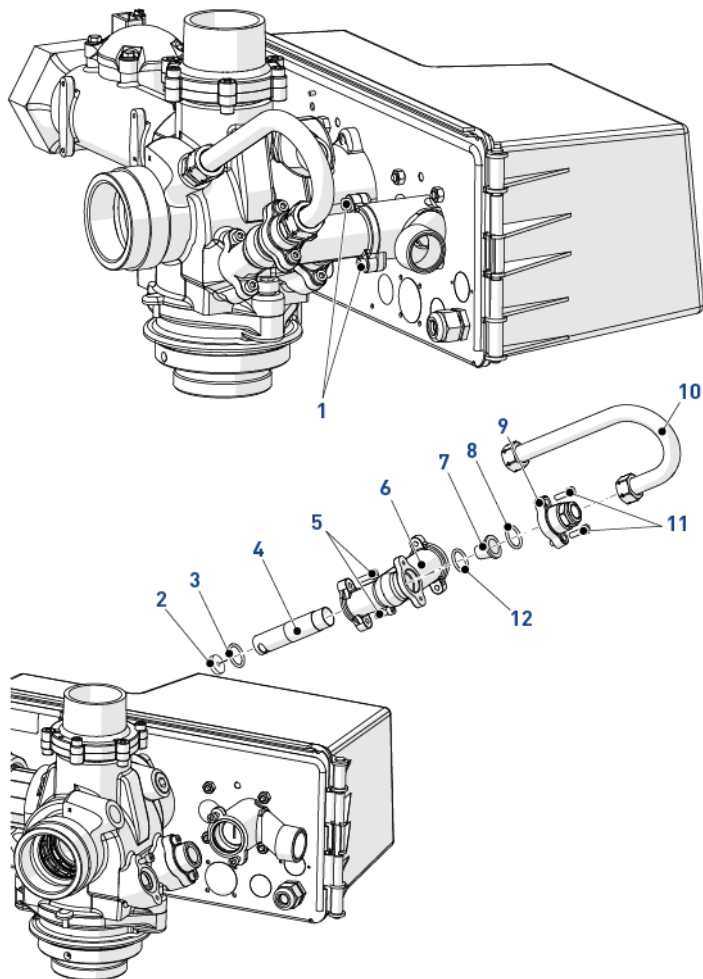

9.4.9 BLFC cleaning

- a) Using a 34 mm wrench, remove the flow control housing (1) from the valve.
- b) Using pliers, remove the retaining ring (6), the flow control retainer (5), the washer holder (3) and the washer (4).
- c) Remove the washer (4) from washer holder (3).
- d) Clean or change the washer (4).
- e) Lubricate the seal (2) with approved silicone lubricant only.
- f) Follow the procedure three first steps in reverse order to rebuild.

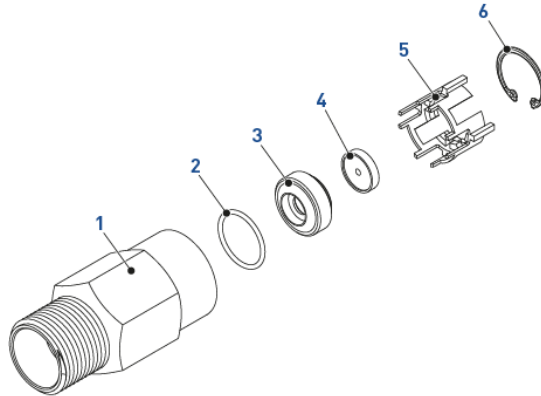

9.4.10 DLFC cleaning

- a) Using a 5 mm Allen wrench, unscrew (1) and remove the housing (2).
- b) Remove the cover plate (4) and the seat (6).
- c) Remove the washers (5) from the seat (6).
- d) Clean or change the washers (5).
- e) Lubricate the seal (3) with approved silicone lubricant only.
- f) Follow the procedure three first steps in reverse order to rebuild.



Mandatory

The washers (5) have to be installed with their chamfered side upfront the water stream flow. Flow indication must be visible after the washer (5) is placed on the seat (6).

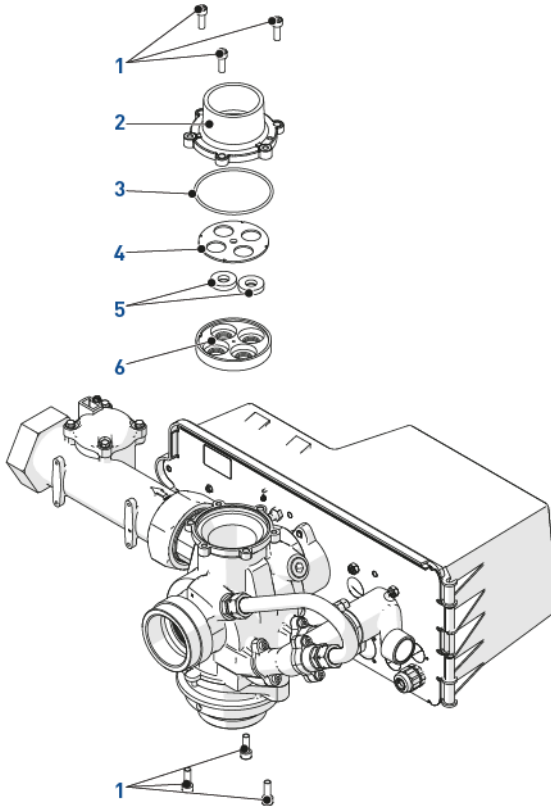

9.4.11 Valve on tank assembly

- a) Lubricate the Oring with approved silicone grease.
- b) Spin the valve **[1]** onto the tank **[2]**, ensuring the threads are not cross-threaded.
- c) Rotate the valve **[1]** clockwise and freely, without using force until it comes to a stop.



Info

This stop position is considered point zero.

- d) Rotate the valve **[1]** clockwise from point zero to between ¼ turn and ½ turn.



CAUTION

Do NOT exceed 27 Nm of torque when installing the valve. Exceeding this limit may damage the threads and cause failure.

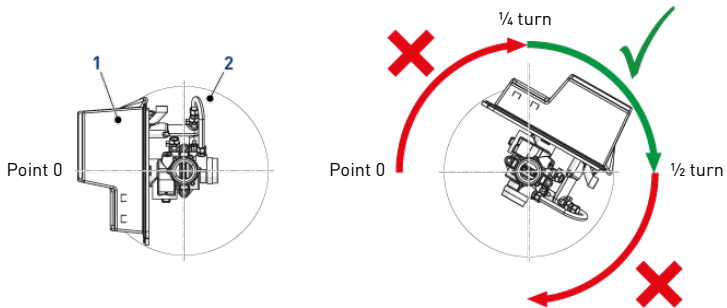

10 Troubleshooting

10.1 Error detection



Info

It can take up to 30 seconds before an error can be detected and displayed.



Mandatory

All the errors must be displayed on each controller before they can be corrected.

- If an error is detected, the status LED light will be red;
- during an error condition, the unit continues to monitor flow and update the remaining capacity. Once an error condition is corrected, the unit returns to the operating status it was in prior to the error, and regeneration resumes according to normal programming;
- if an error is cleared by reprogramming the unit in the Master Programming Mode, the volume remaining may be reset to the full unit capacity (as though it had just regenerated);
- if an error is present, a regeneration can only occur manually by pressing and holding or for 5 seconds;
- if the unit was in regeneration when the error occurred, it completes the regeneration cycle and goes to service;
- when the problem is corrected, and the error no longer displays (it may take several seconds for the unit to stop displaying the error message), the unit returns to normal operation. The status LED light is no longer Red, and turns Green if the unit is regenerating, or Blue if the unit is in service.

Problem	Cause	Solution
Water softener fails to regenerate	Electrical service to unit has been interrupted.	Assure permanent electrical service (check fuse, plug, switch...).
	Timer is defective.	Replace controller.
	Power failure.	Reset time of day.

Problem	Cause	Solution
Hard water	By-pass valve is open.	Close by-pass valve.
	No salt is in brine tank.	Add salt to brine tank and maintain salt level above water level.
	Injector screen plugged.	Clean injector screen.
	Insufficient water flowing into brine tank.	Check brine tank fill time and clean brine line flow control if pugged.
	Leak at the distributor tube.	Make sure distributor tube is not cracked. Check o-ring and tube pilot.
	Internal valve leak.	Replace seals and spacers and/or piston.
Excessive salt consumption	Improper salt setting.	Check salt usage and salt setting.
	Excessive water in brine tank.	See problem "Excessive water in brine tank" below.
Controller cycles continuously	Maladjusted, broken or shorted micro-switch.	Determine if micro-switch or controller is faulty and replace it, or replace complete power head.
Loss of water pressure	Iron buildup in line to water softener.	Clean line to water softener.
	Iron buildup in water softener.	Clean controller and add mineral cleaner to mineral bed. Increase frequency of regeneration.
	Inlet of softener plugged due to foreign material broken loose from pipes by recent work done on plumbing system.	Remove piston and clean the controller.
Loss of mineral through drain line	Air in water system.	Assure that well system has proper air eliminator control. Check for dry well condition.
	Improperly sized drain line flow control.	Check for proper drain rate.
Iron in conditioned water	Fouled mineral bed.	Check backwash, brine draw and brine tank refill. Increase frequency of regeneration. Increase backwash time.

Problem	Cause	Solution
Excessive water in brine tank	Plugged drain line flow control.	Clean flow control.
	Plugged injector system.	Clean injector and screen.
	Controller is not cycling.	Replace controller.
	Foreign material in brine valve.	Replace brine valve seat and clean valve.
	Foreign material in brine line flow control.	Clean brine line flow control.
Softener fails to draw brine	Drain line flow is plugged.	Clean drain line flow control.
	Injector is plugged.	Clean injector.
	Injector screen is plugged.	Clean screen.
	Line pressure is too low.	Increase line pressure to 1.4 bar.
	Internal valve leaks.	Change seals, spacers and piston assembly.
	Cam did not cycle.	Check drive motor and micro-switches.
Drain flows continuously	Controller is not programming correctly.	Check controller program and positioning of controls. Replace power head assembly if not positioning properly.
	Foreign material in valve body.	Remove power head assembly and inspect bore. Remove foreign material and check valve body in various regeneration positions.
	Internal valve leak.	Replace seals and piston assembly.

10.2 Programming error

If reprogramming the unit clears the error, the remaining volume may be reset to full unit capacity (as if it had just regenerated).

- All the units in service remain in service;
- all the units in standby go to service;
- when the error appears, the unit in regeneration finishes the regeneration and goes to service;
- no regeneration starts while the error condition remains.

When the programming problem is corrected and the error is no longer displayed (it may take several seconds for all the units of the system to stop displaying the error), the system returns to normal operation.

Some examples of programming errors detected are:

- valve address doubled;
- power failure;
- system size: ex. programmed for 4 units, but there are only 2 units;
- units of measure do not correspond between the different valves of the system;
- wrong type of valve programmed.

Cause	Solution
More than one unit programmed with the same position number.	Program correctly the units using only once per position number.
Flashing display.	There was a power failure.
Units of measure do not correspond: units have different units of measure programmed.	Check and program all units in the system with the same units of measure.
System size: the number of units in the system does not correspond to the number programmed and vice versa.	Check to make sure that system number and number of units correspond.

10.3 Examples of error displayed

10.3.1 NXT controller

- The unit 2 has been reset;
 - Reprogram the unit.
- there is no message from unit 3;
 - The number indicate the unit to be checked in the system.
 - Check that communication cables are connected.
 - Check the valve address.
- there are more units in the system than programmed in the lead (#1) unit;
- the programmed values do not match, check the values programmed in each unit;
 - Example: Display format different from one unit to the other.
 - Example: System of 4 units, but only 2 detected or connected.
- programmed position of units incorrect.
 - Lead unit (#1) not programmed.
 - 2 or more units are programmed with the same address.

```
DETECTED ERROR =
E2   RESET UNIT
```

```
ERROR   DETECTED
NO      MESSAGE 3
```

```
ERROR   DETECTED
SYSTEM SIZE !
```

```
ERROR   DETECTED
ERROR   PROGRAM
```

```
ERROR   DETECTED
ADDRESS OK
```

10.3.2 NXT2 controller

- Number of NXT2 detected does not match selected system type in Master Programming;
 - Push correct valve settings in Master Settings and check wiring.
- the motor is on but no encoder pulses are detected or CAM Switches change state within a given duration;
 - Verify correct valve type is chosen. Trigger a manual regeneration.
- motor current exceeds thresholds;
 - Call your supplier.
- flow exceeded specified threshold for a specific duration;
 - Call water treatment specialist.
- during a setting push, a packet was missing;
 - Reconnect communication cables and push setting in Master Settings.
- the system type among connected units does not match;
 - Push correct system settings in Master Settings. Check all programming steps without changing settings.
- hardware or software error;
 - Call your supplier.
- 100 Days have expired without a regeneration;
 - Trigger a manual regeneration. Check user programming, meter cable and meter functionality.

ERROR ⓘ
VALUE COUNT MISMATC

MOTOR RUN-ON ⓘ
NO CAM SWITCH CHANGE

OVER-CURRENT ⓘ
MOTOR OVER-CURRENT

FLOW METER ERROR ⓘ
CONTINUOUS FLOW DET

ERROR ⓘ
SEND/RECEIVE FAILL

ERROR ⓘ
SYSTEM TYPE MISMATCH

MICROCONTROLLER ER ⓘ

100 DAYS WITHOUT REG ⓘ

11 Spare parts and options

11.1 Valve parts list

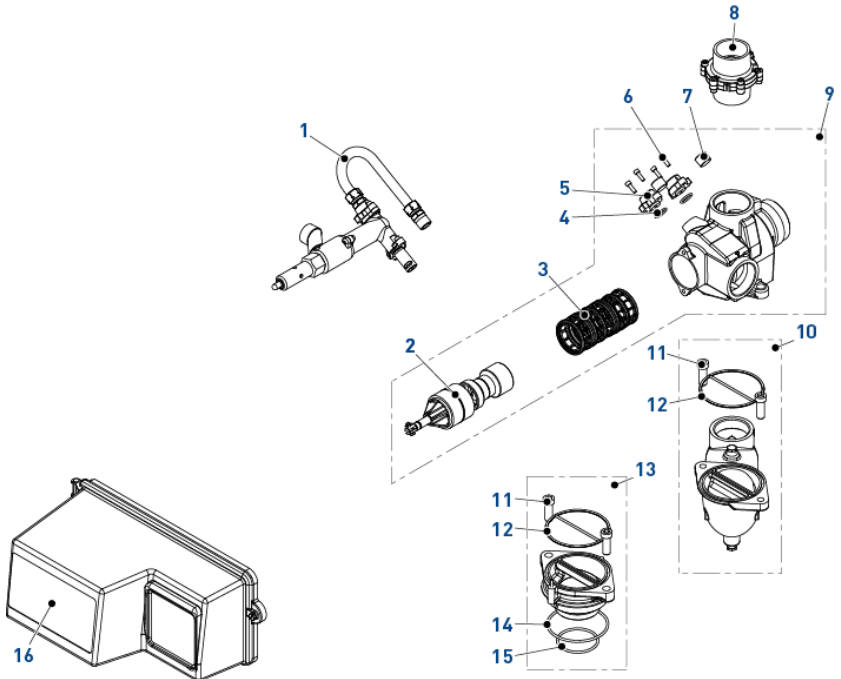

Item	Part number	Description	Packaging quantity
1	26745-4	Brine valve 1800 assy 3900 down flow	1
-	26745-5	Brine valve 1800 assy 3900 down flow	1
-	26745-6	Brine valve 1800 assy 3900 down flow	1
-	26745-7	Brine valve 1800 assy 3900 down flow	1
-	26745-8	Brine valve 1800 assy 3900 down flow	1
-	26745-9	Brine valve 1800 assy 3900 down flow	1
-	26745-10	Brine valve 1800 assy 3900 down flow	1
2	60106-00	Piston assy 3150 upper down flow	1
-	60106-10	Piston assy 3150 up flow	1
-	60113-01	Piston assy 3150 NBP – down flow	1
3	18022	Seals & spacers kit 3150 upper	1
4	15246-01SP	O-ring 560 CD	10
5	16341-02	Injector plug 1800	1
6	19677SP	Screw	10

Item	Part number	Description	Packaging quantity
7	16387	Valve body plug 1/2" NPT 3150/3900	1
8	25580-ALL	DLFC kit 2" 3150 30 to 100 gpm	1
9	BU28516-01	Valve body assy 3150 WBP	1
-	BU28516-02	Valve body assy 3150 NBP	1
-	BU28516-03	Valve body assy 3150 up flow	1
10	18023	Tank adapter assy 3150 SM	1
11	25165SP	Screw THM 12x35	10
12	15112	Seal 3150 adapter base	1
13	18024	Tank adapter assy 3150 TM	1
14	13575-01SP	O-ring 560 CD top of tank	5
15	25823	O-ring 63mm 3150 TM	1
16	PH3150-001	Power head 3150 24V / 50Hz grey without timer	1
-	PH3150-002	Power head 3150 NXT 24V / 50Hz	1

11.2 Power head 3150 parts list

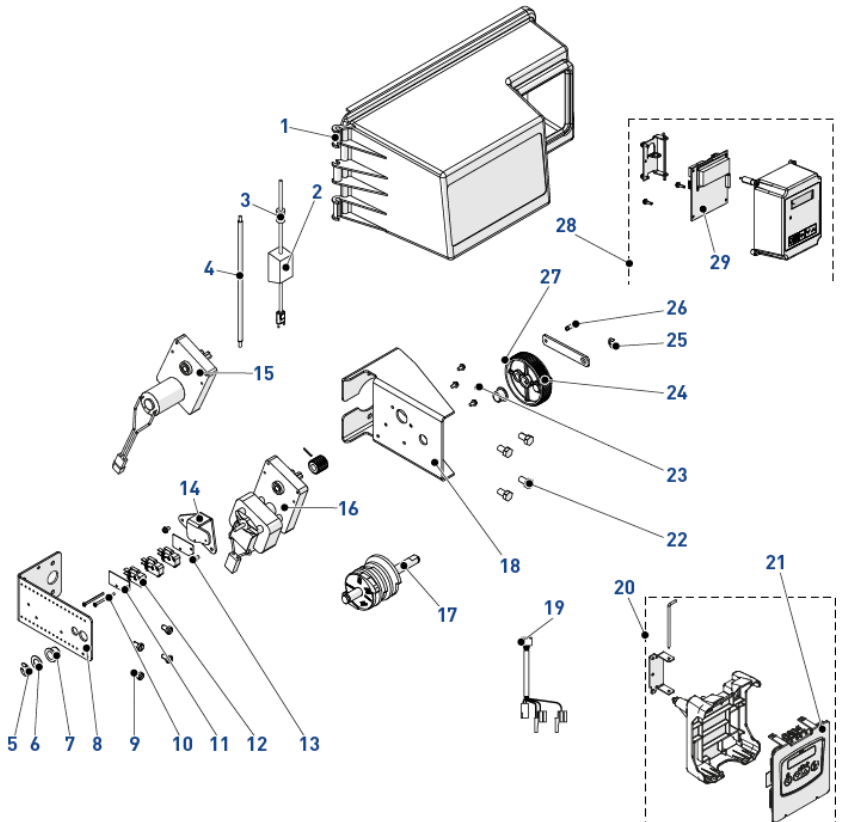

Item	Part number	Description	Packaging quantity
1	26637	Cover assy 3150 upper grey	1
2	26260	Transformer 24 VAC, 60 VA	1
-	44415	Transformer 24 VDC	1
3	17967	Liquid tight	1
4	25352	Guide cable & cable assy 3150 2"	1
5	16051SP	Retaining ring	10
6	16059SP	Washer	10
7	16052SP	Bushing	10
8	16053	Bracket brine side	1
9	23728SP	Screw THM 6x12	8
10	40080SP	Screw microswitch	10
11	10302SP	Insulator limit switch	10

Item	Part number	Description	Packaging quantity
12	10218SP	Microswitch	5
13	10872SP	Screw motor mounting	10
14	17797	Bracket switch mounting	1
15	29212	Drive motor assy 3150 24 VDC	1
16	28409-01	Drive motor assy 3150 24 VAC	1
-	28409-03	Drive Motor assy 3150/3900 230 VAC	1
17	16494-04	Cam assy 3150 upper up flow grey	1
-	16494-05	Cam assy 3150 upper down flow black	1
18	15120-01	Bracket motor 3150	1
19	40941	Wire Harness, upper driver	1
20	21594	Controller assy NXT2	1
21	21595	Circuit board NXT2	1
22	21361SP	Screw TCHCM 8x16	10
23	11080SP	Screw flat head	10
24	18963-31	Drive gear 3150 adapter	1
25	16050SP	Retaining ring	10
26	11709	Pin link 3150	1
27	11898SP	Clip 3150	10
28	BU28713	Controller assy NXT	1
29	BR61702-03	Circuit board NXT	1

11.3 1800 injector parts list

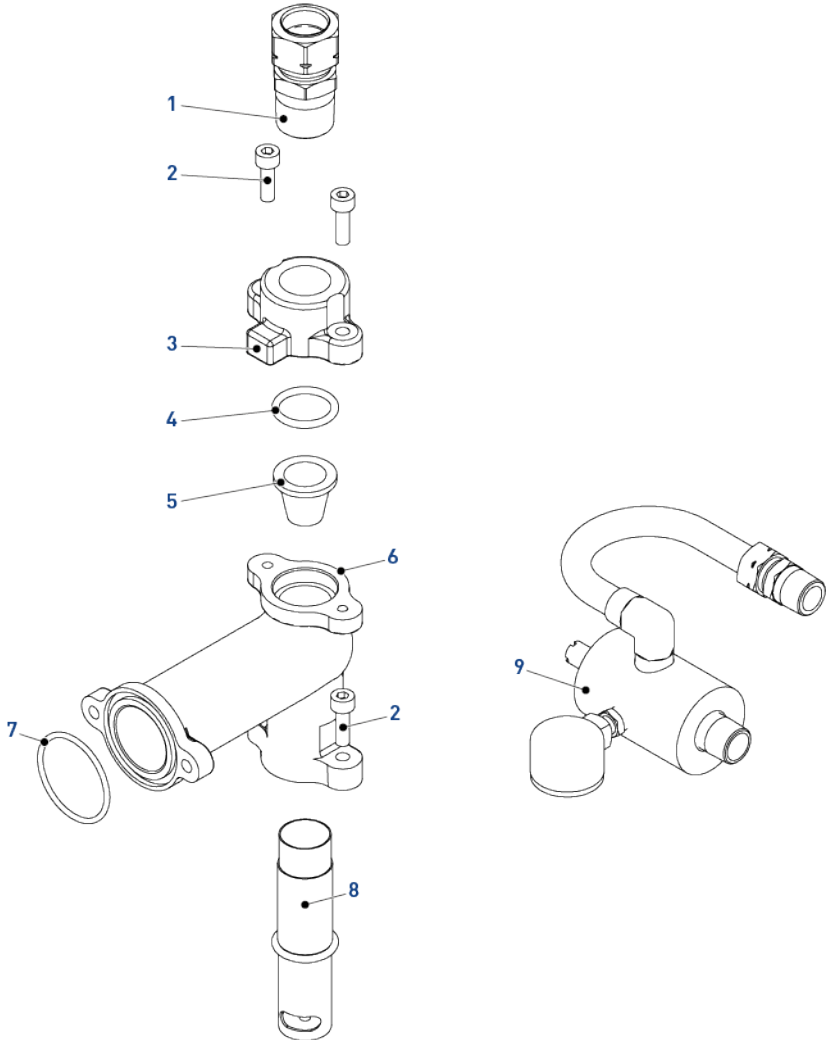

Item	Part number	Description	Packaging quantity
1	18702	Fitting, tube 1/2 NPT 5/8	1
2	19677SP	Screw	10
3	16341-01	Inj cover 1800	1
4	15246-01SP	O-ring - 560CD	1
5	15128-04SP	Injector nozzle # 4	1
-	15128-05SP	Injector nozzle # 5	1

Item	Part number	Description	Packaging quantity
-	15128-06SP	Injector nozzle # 6	1
-	15128-07SP	Injector nozzle # 7	1
-	15128-08SP	Injector nozzle # 8	1
-	15128-09SP	Injector nozzle # 9	1
-	15128-10SP	Injector nozzle # 10	1
6	16340-20	Injector body DF	1
-	16340-21	Injector body UF	1
7	19054SP	O-ring	1
8	15127-04	Injector throat #4	1
-	15127-05	Injector throat #5	1
-	15127-06	Injector throat #6	1
-	15127-07	Injector throat #7	1
-	15127-08	Injector throat #8	1
-	15127-09	Injector throat #9	1
-	15127-10	Injector throat #10	1
9	60734	Pressure regulator assy 3150/3900	1

11.4 BLFC parts list

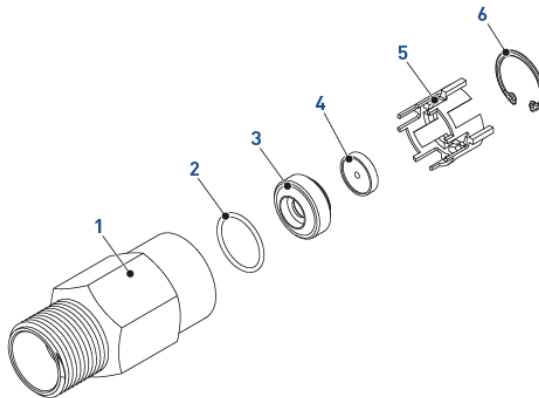

Item	Part number	Description	Packaging quantity
1	BR16530	Flow control housing	1
2	19292SP	O-ring 022	10
3	19053	Flow control retainer 1.5 to 7 gpm	1
-	19279	Flow control retainer 10 to 20 gpm	1
4	12086SP	Washer, flow 1.5 gpm	10

Item	Part number	Description	Packaging quantity
-	12087SP	Washer, flow 2.0 gpm	10
-	12089SP	Washer, flow 3.0 gpm	10
-	12090SP	Washer, flow 3.5 gpm	10
-	12092SP	Washer, flow 5.0 gpm	10
-	12408SP	Washer, flow 7.0 gpm	10
-	16529SP	Washer, flow 10.0 gpm	5
-	16736SP	Washer, flow 15.0 gpm	5
-	16528SP	Washer, flow 20.0 gpm	5
5	16738SP	Flow control retainer	10
6	16805SP	Retaining ring	10

11.5 DLFC parts list

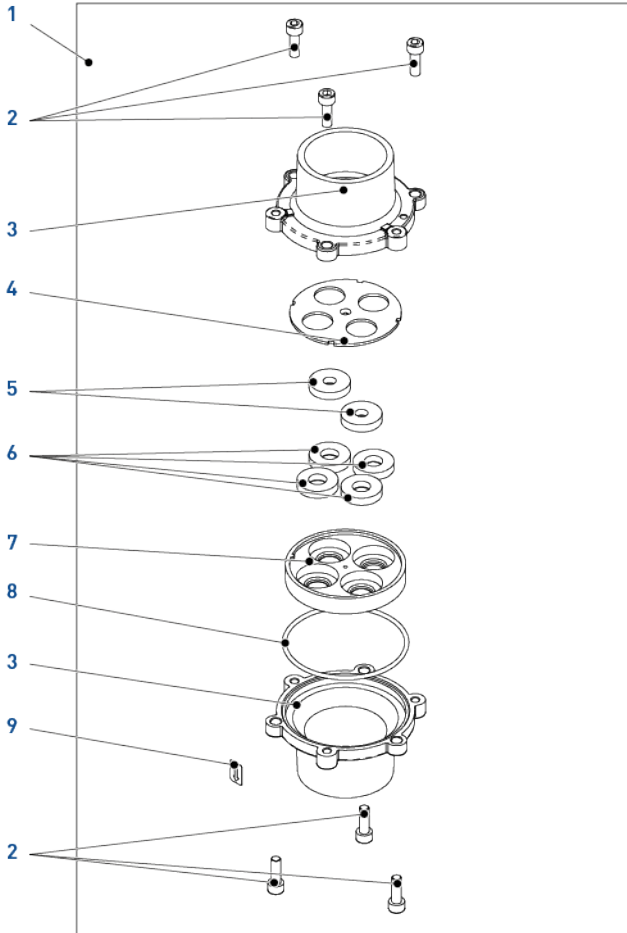

Item	Part number	Description	Packaging quantity
1	25580-ALL	2" DLFC assy 3150/3900 (30-100 gpm)	1
2	25177	Screw	10
3	27913-21	2" Flow control housing - BSP	2
4	16650	Plate, DLFC cover	1
5	16529	Flow controller washer 10 gpm	2
6	16736	Flow controller washer 15 gpm	4
-	16528	Flow controller washer 20 gpm	4
-	16737	Flow controller washer 25 gpm	4
7	16649	Holder DLFC button	1

Item	Part number	Description	Packaging quantity
8	16804	O-ring	1
9	BU28656	Label	1

11.6 Safety brine valves list

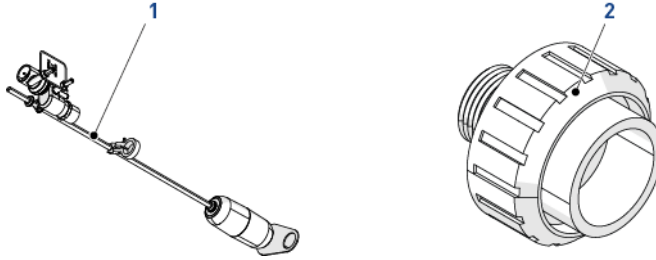

Item	Part number	Description	Packaging quantity
1	25453	SBV 2350 – without air check	5
2	28182	Union PVC female 1" to be glued - male 1" BSP	5

11.7 Distribution systems parts list



CAUTION

Respect the valve sizing configuration to avoid the resin to leak through the valve.



Info

The 0.2 mm and 0.3 mm slots are used for softening systems and the 0.5 mm slots are used for filtering systems.

11.7.1 Thread 4", tank 21" to 36", TM, slots 0.2 mm

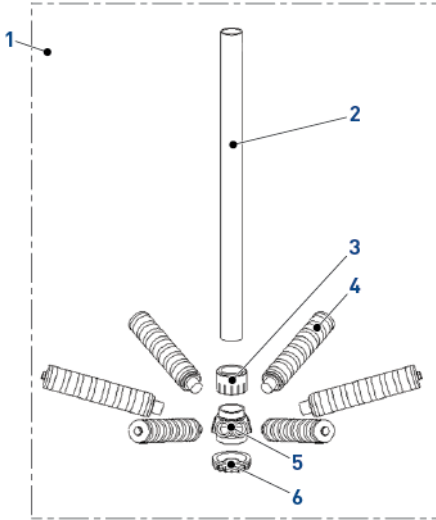

Item	Part number	Description	Packaging quantity
1	A-2163-TM	Distribution system assy, tanks 21" - 24"	1
-	A-3063-TM	Distribution system assy, tank 30"	1
-	A-3663-TM	Distribution system assy, tank 36"	1
2	A-PVC-063	Riser tube	1
3	A-1074-1	Reducing bush	1
4	A-TH02-113	Lateral 113 mm, tanks 14" - 18"	6
-	A-TH02-175	Lateral 175 mm, tanks 21" - 24"	6
-	A-TH02-268	Lateral 268 mm, tank 30"	6
-	A-TH02-330	Lateral 330 mm, tank 36"	6
5	ATD-H60-00	Hub	1
6	AC-H60-00	Hub cap	1

11.7.2 Flanged 6", tank 21" to 36", TM, slots 0.2 mm

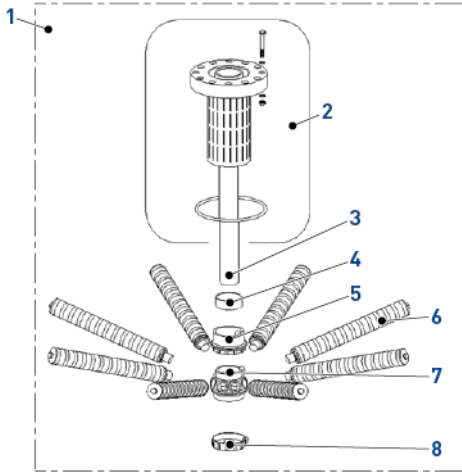

Item	Part number	Description	Packaging quantity
1	A-TF21-063	Distribution system assy, tanks 21" - 24"	1
-	A-TF30-063	Distribution system assy, tank 30"	1
-	A-TF36-063	Distribution system assy, tank 36"	1
2	A-3100-14C	Adapter	1
3	A-PVC-063	Riser tube	1
4	A-3050-91	Reducing bush	1
5	AB-GC8-30	Reducing bush	1
6	A-TH02-175	Lateral 175 mm, tanks 21" - 24"	8
-	A-TH02-268	Lateral 268 mm, tank 30"	8
-	A-TH02-330	Lateral 330 mm, tank 36"	8
7	ATD-H80-00	Hub	1
8	AD-H80-00	Hub cap	1

11.7.3 Flanged 6", tank 42", TM, slots 0.2 mm

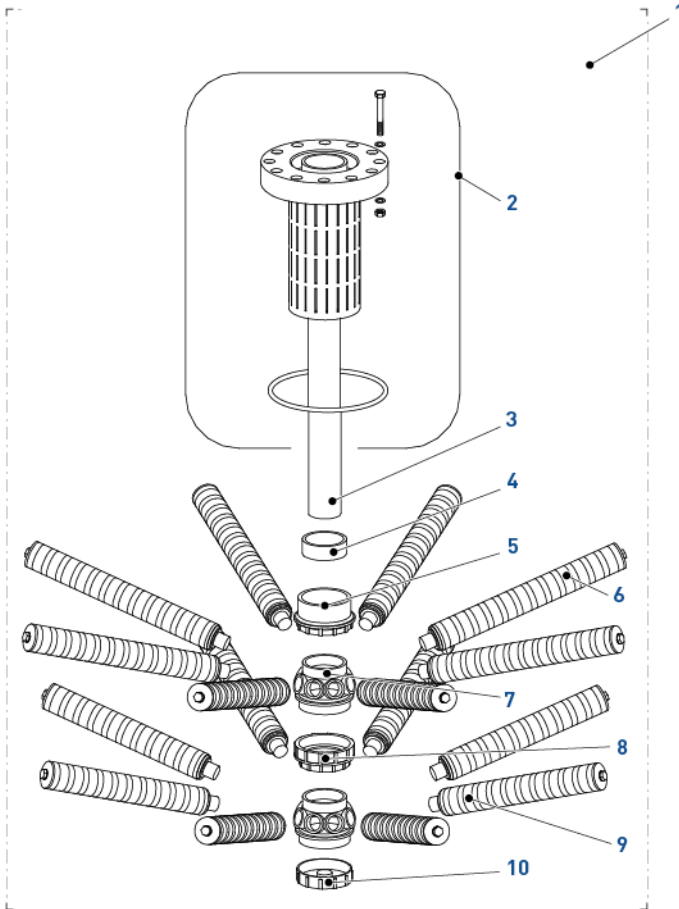

Item	Part number	Description	Packaging quantity
1	A-TF42-063	Distribution system assy, tank 42"	1
2	A-3100-14C	Adapter	1
3	A-PVC-063	Riser tube	1
4	A-3050-91	Reducing bush	1
5	AB-GC8-30	Reducing bush	1
6	A-TH02-423	Lateral 423 mm, tank 42	8
7	ATD-H80-00	Hub	2
8	AB-C08-40	Connection	1
9	A-TH02-361	Lateral 361 mm, tank 42	8
10	AD-H80-00	Hub cap	1

11.7.4 Threaded 4", tank 21" to 36", SM, top distribution, elbow 63 mm, external glue connection

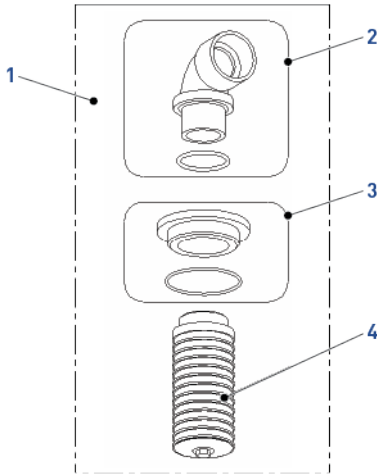

Item	Part number	Description	Packaging quantity
1	A-2727-63	Top distribution system assy, slots 0.2 mm	1
-	A-2727-65	Top distribution system assy, slots 0.5 mm	1
2	A-2693-C	Elbow	1
3	A-2752-11C	Adaptor	1
4	A-2740--	Diffuser, slots 0.2 mm	1
-	A-2746--	Diffuser, slots 0.5 mm	1

11.7.5 Threaded 4", tank 21" to 36", SM, bottom distribution, elbow 63 mm, external glue connection

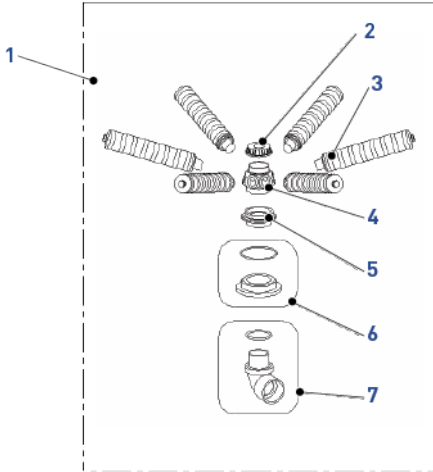

Item	Part number	Description	Packaging quantity
1	A-2821-63	Bottom distribution system assy, tanks 21" - 24", slots 0.2 mm	1
-	A-2821-65	Bottom distribution system assy, tanks 21" - 24", slots 0.5 mm	1
-	A-2830-63	Bottom distribution system assy, tank 30", slots 0.2 mm	1
-	A-2830-65	Bottom distribution system assy, tank 30", slots 0.5 mm	1
-	A-2836-63	Bottom distribution system assy, tank 36", slots 0.2 mm	1
-	A-2836-65	Bottom distribution system assy, tank 36", slots 0.5 mm	1
2	AD-H60-00	Hub cap	1
3	A-TH02-175	Lateral 175 mm, tanks 21" - 24", slots 0.2 mm	6
-	A-TH05-175	Lateral 175 mm, tanks 21" - 24", slots 0.5 mm	6
-	A-TH02-268	Lateral 268 mm, tank 30", slots 0.2 mm	6
-	A-TH05-268	Lateral 268 mm, tank 30", slots 0.5 mm	6
-	A-TH02-330	Lateral 330 mm, tank 36", slots 0.2 mm	6
-	A-TH05-330	Lateral 330 mm, tank 36", slots 0.5 mm	6
4	ATD-H60-00	Hub	1
5	AB-A6F-20	Hub adaptor	1
6	A-2106-48	Adaptor	1

Item	Part number	Description	Packaging quantity
7	A-2693-C	Elbow	1

11.7.6 Threaded 4", tank 21" to 36", SM, top distribution, straight 63 mm, external glue connection

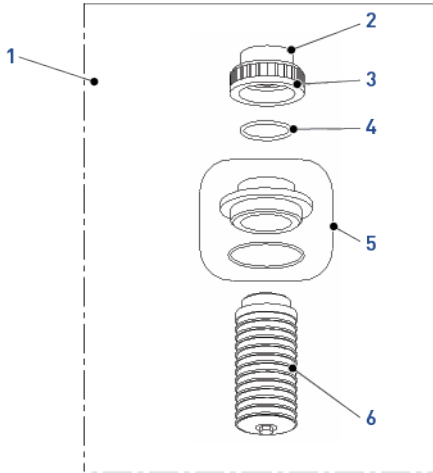

Item	Part number	Description	Packaging quantity
1	A-27UN-63	Top distribution system assy, slots 0.2 mm	1
-	A-27UN-65	Top distribution system assy, slots 0.5 mm	1
2	A-8200-63	Union nut	1
3	A-8250-63	Collar	1
4	A-2694-17	O-ring	1
5	A-2752-32	Adapter	1
6	A-2740--	Diffuser, slots 0.2 mm	1
-	A-2746--	Diffuser, slots 0.5 mm	1

11.7.7 Threaded 4", tank 21" to 36", SM, bottom distribution, straight 63 mm, external glue connection

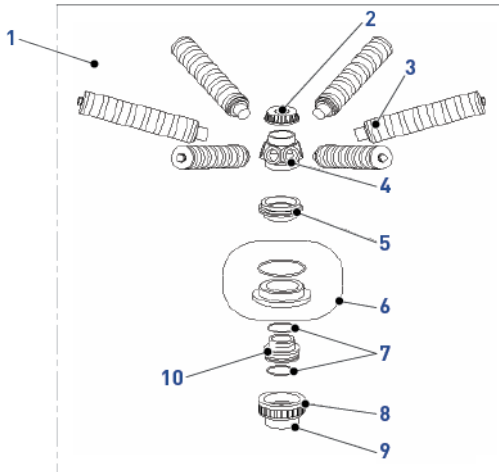

Item	Part number	Description	Packaging quantity
1	A-21UN-63	Bottom distribution system assy, tanks 21" - 24", slots 0.2 mm	1
-	A-21UN-65	Bottom distribution system assy, tanks 21" - 24", slots 0.5 mm	1
-	A-30UN-63	Bottom distribution system assy, tank 30", slots 0.2 mm	1
-	A-30UN-65	Bottom distribution system assy, tank 30", slots 0.5 mm	1
-	A-36UN-63	Bottom distribution system assy, tank 36", slots 0.2 mm	1
-	A-36UN-65	Bottom distribution system assy, tank 36", slots 0.5 mm	1
2	AD-H60-00	Hub cap	1
3	A-TH02-175	Lateral 175 mm, tanks 21" - 24", slots 0.2 mm	6
-	A-TH05-175	Lateral 175 mm, tanks 21" - 24", slots 0.5 mm	6
-	A-TH02-268	Lateral 268 mm, tank 30", slots 0.2 mm	6
-	A-TH05-268	Lateral 268 mm, tank 30", slots 0.5 mm	6
-	A-TH02-330	Lateral 330 mm, tank 36", slots 0.2 mm	6
-	A-TH05-330	Lateral 330 mm, tank 36", slots 0.5 mm	6
4	ATD-H60-00	Hub	1
5	AB-A6F-20	Hub adaptor	1
6	A-2106-48	Adaptor	1

Item	Part number	Description	Packaging quantity
7	A-2694-17	O-ring	2
8	A-8200-63	Union nut	1
9	A-8250-63	Collar	1
10	A-2700-234	Adaptor	1

11.7.8 Flanged 6", tank 21" to 36", SM, top distribution, external flange 65 mm connection

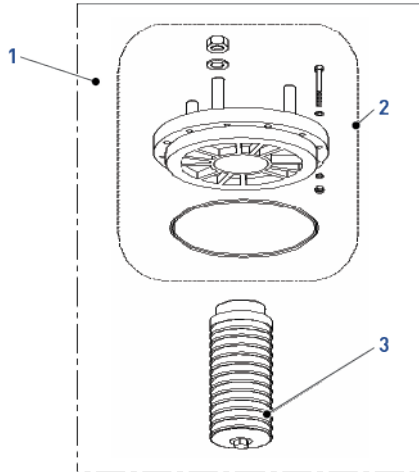

Item	Part number	Description	Packaging quantity
1	A-2727-F6	Top distribution system assy, slots 0.2 mm	1
-	A-2527-F6	Top distribution system assy, slots 0.5 mm	1
2	A-3100-02C	Adaptor	1
3	A-2740--	Diffuser, slots 0.2 mm	1
-	A-2746--	Diffuser, slots 0.5 mm	1

11.7.9 Flanged 6", tank 21" to 36", SM, bottom distribution, external flange 65 mm connection

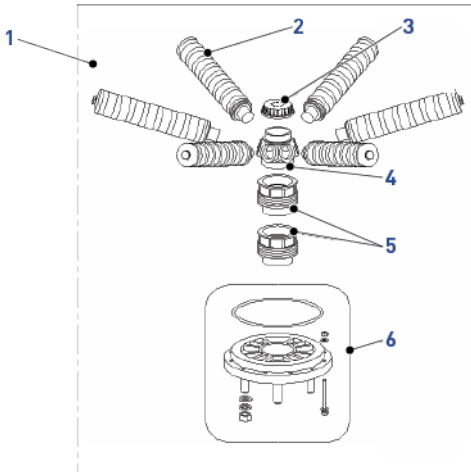

Item	Part number	Description	Packaging quantity
1	A-2721-F6	Bottom distribution system assy, tanks 21" - 24", slots 0.2 mm	1
-	A-2521-F6	Bottom distribution system assy, tanks 21" - 24", slots 0.5 mm	1
-	A-2730-F6	Bottom distribution system assy, tank 30", slots 0.2 mm	1
-	A-2530-F6	Bottom distribution system assy, tank 30", slots 0.5 mm	1
-	A-2736-F6	Bottom distribution system assy, tank 36", slots 0.2 mm	1
-	A-2536-F6	Bottom distribution system assy, tank 36", slots 0.5 mm	1
2	A-TH02-175	Lateral 175 mm, tanks 21" - 24", slots 0.2 mm	6
-	A-TH05-175	Lateral 175 mm, tanks 21" - 24", slots 0.5 mm	6
-	A-TH02-268	Lateral 268 mm, tank 30", slots 0.2 mm	6
-	A-TH05-268	Lateral 268 mm, tank 30", slots 0.5 mm	6
-	A-TH02-330	Lateral 330 mm, tank 36", slots 0.2 mm	6
-	A-TH05-330	Lateral 330 mm, tank 36", slots 0.5 mm	6
3	AD-H60-00	Hub cap	1
4	ATD-H60-00	Hub	1
5	A-3100-04C	Prolongation	2
6	A-3100-02C	Adaptor	1

11.7.10 Hot water, flanged 6", tank 42" to 63", SM, top and bottom distribution, external flange 80 mm connection, slots 0.2 mm

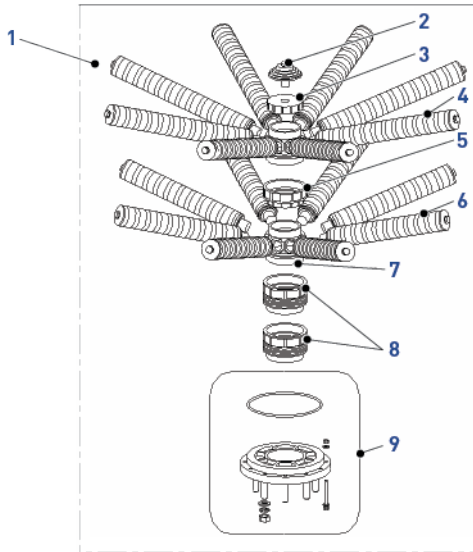

Item	Part number	Description	Packaging quantity
1	A3-2742-FL	Bottom distribution system assy, tank 42"	1
-	A3-2748-FL	Bottom distribution system assy, tank 48"	1
-	A3-2755-FL	Bottom distribution system assy, tank 55"	1
-	A3-2763-FL	Bottom distribution system assy, tank 63"	1
2	A3-2727-10	Filter nozzle	1
3	A3-BTC8-30	Hub cap	1
4	A3-TH02-423	Upper lateral 423 mm, tank 42"	8
-	A3-TH02-485	Upper lateral 485 mm, tank 48"	8
-	A3-TH02-578	Upper lateral 578 mm, tank 55"	8
-	A3-TH02-640	Upper lateral 640 mm, tank 63"	8
5	AB3-C08-40	Connection	1
6	A3-TH02-361	Lower lateral 361 mm, tank 42"	8
-	A3-TH02-423	Lower lateral 423 mm, tank 48"	8
-	A3-TH02-516	Lower lateral 516 mm, tank 55"	8
-	A3-TH02-578	Lower lateral 578 mm, tank 63"	8
7	ATD3-H80-00	Hub	2
8	A-3100-05C	Prolongation	2
9	A-3100-03C	Adaptor	1

11.7.11 Hot water, flanged 6", tank 21" to 36", SM, top and bottom distribution, external flange 65 mm connection, slots 0.2 mm

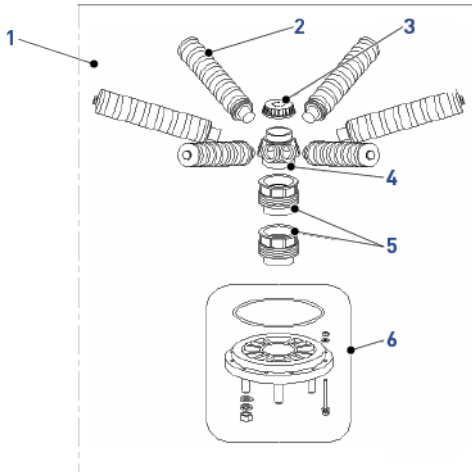

Item	Part number	Description	Packaging quantity
1	A3-2721-F6	Bottom distribution system assy, tanks 21" - 24"	1
-	A3-2730-F6	Bottom distribution system assy, tank 30"	1
-	A3-2736-F6	Bottom distribution system assy, tank 36"	1
2	A3-TH02-175	Lateral 175 mm, tanks 21" - 24"	6
-	A3-TH02-268	Lateral 268 mm, tank 30"	6
-	A3-TH02-330	Lateral 330 mm, tank 36"	6
3	A3D-H60-00	Hubcap	1
4	ATD3-H60-00	Hub distributor	1
5	A-3100-04C	Prolongation	2
6	A-3100-02C	Adaptor	1

11.8 Air checks list

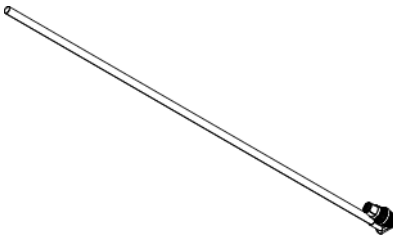

Item	Part number	Description	Packaging quantity
-	18979	Air check 900 - 1m88	5

Item	Part number	Description	Packaging quantity
-	BU28510	Air check 900 - 1m10	5
-	18980	Air check 900 HW	5

11.9 Meters parts list

11.9.1 Brass meters parts list

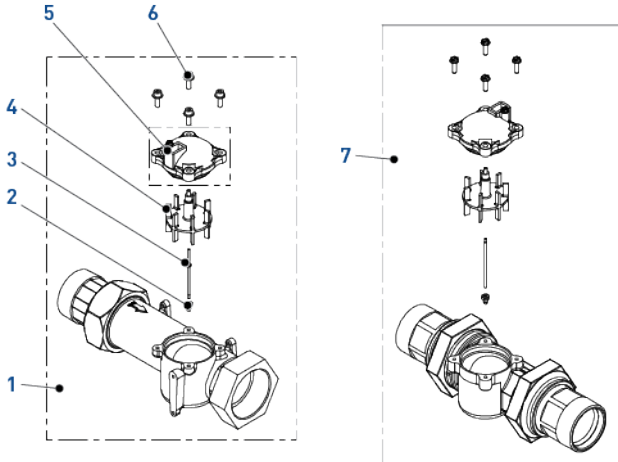

Item	Part number	Description	Packaging quantity
1	18393	Meter assy 2" electronic	1
2	15532	Impeller shaft bearing	1
3	BR15432	Impeller shaft for impeller 15374-01	1
4	BR15374	Impeller 2"	1
5	18330	Meter cover assy electronic	1
6	12473SP	Screw hex washer 10-24x $\frac{5}{8}$ 18-8SS	50
7	60625-10	Meter assy 2" electronic plastic	1

11.9.2 Stainless steel meters parts list

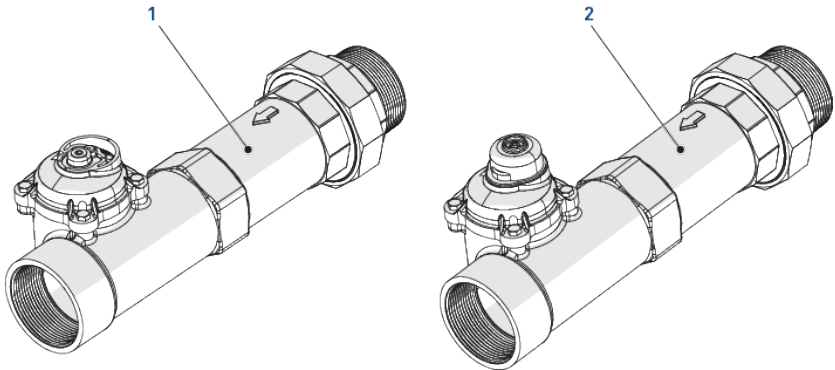

Item	Part number	Description	Packaging quantity
1	29094	Meter assy SS 2" BSP Mechanical 75 m ³ / Electronic	1
2	29095	Meter assy SS 2" BSP Mechanical 375 m ³	1

11.10 Kit meter & Meter cables list

11.10.1 Mecanical cable meter

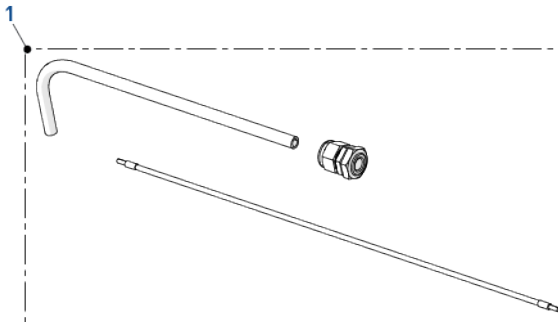

Item	Part number	Description	Packaging quantity
1	25352	Guide cable & cable assy 3150 2"	1

11.10.2 Brass kit meter & Meter cables list

Item	Part number	Description	Packaging quantity
-	28283	Kit meter assy 1" NT /NXT	1
-	28284	Kit meter assy 1.5" NT /NXT	1
-	28285	Kit meter assy 2" NT /NXT	1
-	28286	Kit meter assy 3" NT /NXT	1

Item	Part number	Description	Packaging quantity
-	19121-08	Meter cable SE/SXT 0.75 m	1
-	19121-09	Meter cable NT /NXT 2.5 m	1
-	19121-10	Meter cable NT /NXT 7.7 m	1

11.10.3 Stainless steel kit meter & Meter cables list

Item	Part number	Description	Packaging quantity
-	29096	Kit meter assy 1" stainless NXT	1
-	29097	Kit meter assy 1.5" stainless NXT	1
-	29098	Kit meter assy 2" stainless NXT	1
-	29082	Kit meter assy 3" stainless NXT	1
-	BR19791-02	Meter cable electronic 0.75 m	1
-	BR19791-04	Meter cable electronic 2.5 m	1
-	BR19791-05	Meter cable electronic 7.7 m	1

11.11 Kits

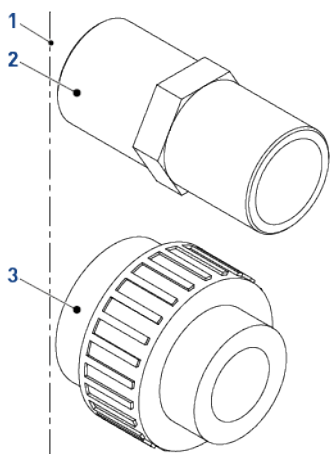

Item	Part number	Description	Packaging quantity
1	Kit 78	Male pipe fitting 1" and PVC Union Female 1" BSP	1
2	16453	Male pipe fitting 1"	1
3	28181	PVC Union Female 1" BSP	2

11.12 Other components list

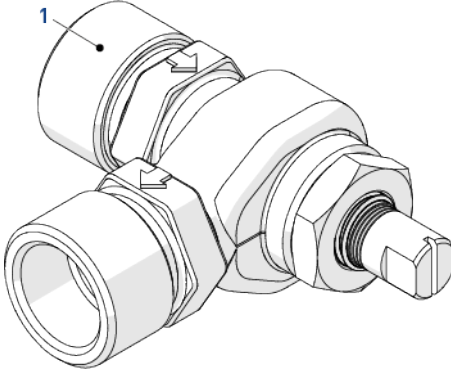

Item	Part number	Description	Packaging quantity
1	BU61564-10	Mixing assy 1" Industrial	1

12 Disposal

The device must be scrapped in accordance with directive 2012/19/EU or the environmental standards in force in the country of installation. The components included in the system must be separated and recycled in a waste recycling center that conforms with the legislation in force in the country of installation. This will help to reduce the impact on the environment, health, safety and help to promote recycling. Pentair do not collect used product for recycling. Contact your local recycling center for more information.





www.pentairaqueurope.com