



FLECK 3900 NXT/NXT2



INSTALLER MANUAL

Table of Contents

1	Generalities	7
1.1	Scope of the documentation	7
1.2	Release management	7
1.3	Manufacturer identifier, product	7
1.4	Intended use	8
1.5	Abbreviations used	8
1.6	Norms	8
1.6.1	Applicable norms	8
1.6.2	Available certificates	9
1.7	Procedure for technical support	9
1.8	Copyright	9
1.9	Limitation of liability	10
1.10	Scan & Service application	11
2	Safety	12
2.1	Safety pictograms definition	12
2.2	Serial label location	13
2.3	Hazards	13
2.3.1	Personnel	13
2.3.2	Material	14
2.4	Hygiene and sanitization	14
2.4.1	Sanitary issues	14
2.4.2	Hygiene measures	14
3	Description	15
3.1	Technical specifications	15
3.2	Performance flow rate characteristics	17
3.3	Outline drawing	17
3.4	Components description and location	18
3.4.1	With NXT controller and AC motor	18
3.4.2	With NXT controller and DC motor	19
3.4.3	With NXT2 controller and DC motor	20
3.5	System regeneration cycle	21
3.5.1	Downflow regeneration cycle (5-cycles operation)	21
3.5.2	Upflow regeneration cycle (5-cycles operation)	23
3.5.3	Filter cycle (3-cycles operation)	25
3.6	Injector block position for DF and UF configurations	27
4	System sizing	28
4.1	Recommended Injector/DLFC/BLFC-Valve configuration	28

4.2	Sizing a softener (single unit)	28
4.2.1	Parameters to be considered	28
4.2.2	Determining the required volume of resin	29
4.2.3	Resin exchange capacity and capacity of the unit	30
4.2.4	Valve configuration	31
4.2.5	Cycle time calculation	32
4.3	Salt amount definition	34
4.4	Injector flow rates	34
4.4.1	1800 Injector flow rates	35
5	Installation	37
5.1	Warnings	37
5.2	Safety notices for installation	37
5.3	Installation environment	37
5.3.1	General	37
5.3.2	Water	38
5.3.3	Electrical	38
5.3.4	Mechanical	39
5.4	Integration constraints	39
5.5	Valve connection to piping	40
5.5.1	Top-mounted valve installation	40
5.5.2	Side-mounted valve installation	42
5.6	Block diagram and configuration example	43
5.7	Regeneration flows	45
5.7.1	Single valve (System 4)	46
5.7.2	Multiple valves, parallel interlock system (System 5)	46
5.7.3	Multiple valves, parallel series regeneration system (System 6)	46
5.7.4	Duplex alternating immediate system (System 7)	47
5.7.5	Duplex alternating delayed system (System 8) (NXT2 only)	48
5.7.6	Multiple valves, parallel system with standby unit (System 9)	48
5.7.7	Multiple valves, system on-demand (System 14)	49
5.8	Electrical connections	53
5.8.1	NXT controller connections	54
5.8.2	NXT2 controller connections	55
5.8.3	NXT controller connections for multiple valves	56
5.8.4	NXT2 controller connections for multiple valves	57
5.9	Bypassing	58
5.10	Drain line connection	58
5.11	Overflow line connection	59
5.12	Brine line connection	60
6	Programming	61
6.1	NXT controller	61
6.1.1	Display	61
6.1.2	Commands	62

6.1.3	Setting the time of the day	62
6.1.4	Basic programming.....	62
6.1.5	Master programming mode.....	64
6.1.6	Diagnostic.....	78
6.1.7	Resetting the controller.....	80
6.2	NXT2 Controller.....	82
6.2.1	Display.....	82
6.2.2	Commands.....	84
6.2.3	Time of day menu.....	85
6.2.4	Basic programming.....	86
6.2.5	Master programming mode.....	88
6.2.6	Diagnostic.....	113
6.2.7	Resetting the controller.....	119
7	Commissioning.....	120
7.1	Water filling, draining and waterproofness inspection.....	120
7.1.1	Activating a single valve system (System 4).....	120
7.1.2	Activating a multiple valves system (Systems 5, 6, 7, 8, 9 and 14).....	121
7.2	Sanitization.....	121
7.2.1	Disinfection of water softeners.....	121
7.2.2	Sodium or calcium hypochlorite.....	122
7.2.3	Electro chlorination.....	122
8	Operation.....	123
8.1	Display.....	123
8.1.1	NXT controller.....	123
8.1.2	NXT2 controller.....	123
8.1.3	LED status.....	125
8.2	Recommendations.....	125
8.3	Manual regeneration.....	125
8.3.1	Manual delayed regeneration.....	125
8.3.2	Immediate regeneration.....	126
8.3.3	To advance regeneration cycles.....	126
8.3.4	To stop a regeneration (NXT2 only).....	126
8.4	Operation during a power failure.....	126
9	Maintenance.....	127
9.1	General system inspection.....	127
9.1.1	Water quality.....	127
9.1.2	Mechanical Checks.....	127
9.1.3	Regeneration test.....	128
9.2	Recommended maintenance plan.....	129
9.2.1	Valve used for softening.....	129
9.2.2	Valve used for filtration.....	131
9.3	Recommendations.....	132
9.3.1	Use original spare parts.....	132
9.3.2	Use original approved lubricants.....	132

9.3.3	Maintenance instructions	132
9.4	Cleaning and maintenance.....	132
9.4.1	First steps.....	132
9.4.2	Power head and/or motor replacement	133
9.4.3	Lower power head motor replacement	137
9.4.4	NXT to NXT2 controller upgrade.....	139
9.4.5	NXT2 controller replacement	141
9.4.6	Upper piston and/or seal and spacer kit disassembly/replacement.....	142
9.4.7	Lower piston and/or seal and spacer kit replacement	144
9.4.8	Micro-switches replacement	146
9.4.9	Cams replacement	147
9.4.10	Injector throat and washer cleaning.....	148
9.4.11	BLFC cleaning	149
9.4.12	DLFC cleaning	150
9.4.13	Valve on tank assembly.....	151
10	Troubleshooting	152
10.1	Error detection	152
10.2	Programming error.....	154
10.3	Examples of error displayed	155
10.3.1	NXT controller	155
10.3.2	NXT2 controller.....	155
11	Spare parts and options.....	157
11.1	Valve parts list.....	157
11.2	Power head 3150 parts list.....	159
11.3	Lower power head parts list	161
11.4	1800 injector parts list.....	163
11.5	BLFC parts list.....	164
11.6	DLFC parts list.....	166
11.7	Safety brine valves list	167
11.8	Distribution systems parts list.....	167
11.8.1	Flanged 6", tanks 30" - 36", TM, slots 0.3 mm	168
11.8.2	Flanged 6", tanks 42" - 48", TM, slots 0.3 mm	169
11.8.3	Flanged 6", tanks 42" - 63", TM & SM, bottom distribution, DN100 connections	170
11.8.4	Flanged 6", tanks 42" - 63", SM, top distribution, DN80 connections.....	171
11.8.5	Flanged 6", tanks 42" - 63", SM, bottom distribution, DN80 connections	172
11.9	Tank adapters parts list	174
11.9.1	Flanged 6", tanks adapter, TM.....	174
11.9.2	Threaded 6", tanks adapter, TM.....	175
11.9.3	SM adapter	176
11.10	Air checks list	176
11.11	Meters parts list	177
11.11.1	Brass meters parts list	177

11.11.2	Stainless steel meters parts list.....	178
11.12	Kit meter & Meter cables list.....	178
11.12.1	Mecanical cable meter.....	178
11.12.2	Brass kit meter & Meter cables list.....	179
11.12.3	Stainless steel kit meter & Meter cables list.....	179
11.13	CE compliance parts list	179
11.14	Other components list.....	180
12	Disposal.....	181

1 Generalities

1.1 Scope of the documentation

The documentation provides the necessary information for appropriate use of the product. It informs the user to ensure efficient execution of the installation, operation or maintenance procedures.

The content of this document is based on the information available at the time of publication. The original version of the document was written in English.

For safety and environmental protection reasons, the safety instructions given in this documentation must be strictly followed.

This manual is a reference and will not include every system installation situation. The person installing this equipment should have:

- training in the Fleck series, NXT/NXT2 controllers and water softener installation;
- knowledge of water conditioning and how to determine proper controller settings;
- basic plumbing skills.

This document is available in other languages on <https://www.pentairaqueurope.com/product-finder/product-type/control-valves>.

1.2 Release management

Revision	Date	Authors	Description
A	21.11.2017	BRY/PBO	First edition.
B	13.07.2018	BRY/FIM	Address change, Bleam information and valve on tank assembly.
C	10.12.2019	BRY/FLA	NXT2 controller.

1.3 Manufacturer identifier, product

Manufacturer: Pentair International LLC
Avenue de Sevelin 18
1004 Lausanne
Switzerland

Product: Fleck 3900 NXT/NXT2

1.4 Intended use

The device is intended for industry environment use only and it is purpose-built for water treatment.

1.5 Abbreviations used

Assy	Assembly
BLFC	Brine Line Flow Controller
BV	Brine Valve
CW	Cold Water
DF	Down Flow
DLFC	Drain Line Flow Controller
HW	Hot Water
Inj	Injector
NBP	No By Pass
PH	Power Head
QC	Quick Connect
Regen	Regeneration
S&S	Seals & Spacers
SBV	Safety Brine Valve
SM	Side Mounted
Std	Standard
TC	Time Clock
TM	Top Mounted
UF	Up Flow

1.6 Norms

1.6.1 Applicable norms

Comply with the following guidelines:

- 2006/42/EC: Machinery Directive;
- 2014/35/UE: Low Voltage Directive;
- 2014/30/UE: Electromagnetic compatibility;
- 2011/65/UE: Restriction of use of certain hazardous substances in electrical and electronic equipment (RoHS);
- UNI EN ISO9001.

Meets the following technical standards:

- EN 55014-1;
- EN 55014-2;
- EN 61000-6-1;
- EN 61000-6-2;
- EN 61000-6-3;
- EN 61000-6-4;
- EN 61010-1;
- EN 61000-3-2;
- EN 61000-3-3.

1.6.2 Available certificates

- CE;
 - DM174;
 - ACS.
- Please find beside the certifications for some of our product families. Please note that this list is not an exhaustive list of all our certifications. In case of need for more information please contact us.



1.7 Procedure for technical support

Procedure to follow for any technical support request:

1. Collect the required information for a technical assistance request.
 - ⇒ Product identification [see Serial label location [▶Page 13] and Recommendations [▶Page 132]];
 - ⇒ Description of the device problem.
2. Please refer to the Troubleshooting [▶Page 152]. If the problem persists contact your supplier.

1.8 Copyright

© 2019 Pentair International Sàrl. All rights reserved.

1.9 Limitation of liability

Pentair Quality System EMEA products benefit, under specific conditions, from a manufacturer warranty that may be invoked by Pentair's direct customers. Users should contact the vendor of this product for applicable conditions and in case of a potential warranty claim.

Any warranty provided by Pentair regarding the product will become invalid in case of:



- installation done by a non-water-professional;
- improper installation, improper programming, improper use, improper operation and/or maintenance leading to any kind of product damages;
- improper or unauthorized intervention on the controller or components;
- incorrect, improper or wrong connection/assembly of systems or products with this product and vice versa;
- use of a non-compatible lubricant, grease or chemicals of any type and not listed by the manufacturer as compatible for the product;
- failure due to wrong configuration and/or sizing.

Pentair accepts no liability for equipment installed by the user upstream or downstream of Pentair products, as well as for process/production processes which are installed and connected around or even related to the installation. Disturbances, failures, direct or indirect damages that are caused by such equipment or processes are also excluded from the warranty. Pentair shall not accept any liability for any loss or damage to profits, revenues, use, production, or contracts, or for any indirect, special or consequential loss or damage whatsoever. Please refer to the Pentair List Price for more information about terms and conditions applicable to this product.

1.10 Scan & Service application

Scan & Service mobile application is the ideal support for the maintenance person in his daily business. A simple scan of an identification (ID) label (1) present on the valve with a smartphone (4) gives an instantaneously access to all updated information related to the product, such as:

- valve's and tanks detailed configuration;
- manuals;
- spare parts lists;
- troubleshooting recommendations;
- multi-lingual videos, detailing how to best service a part;
- informations about new products, latest technologies, novelties about the Blue Network program, etc.

1. Download the application "Scan & Service" from  or  in a smartphone (4).
2. Open the application "Scan & Service".
3. Scan the bleam (3) stuck on the valve (2).
4. Navigate to find information.

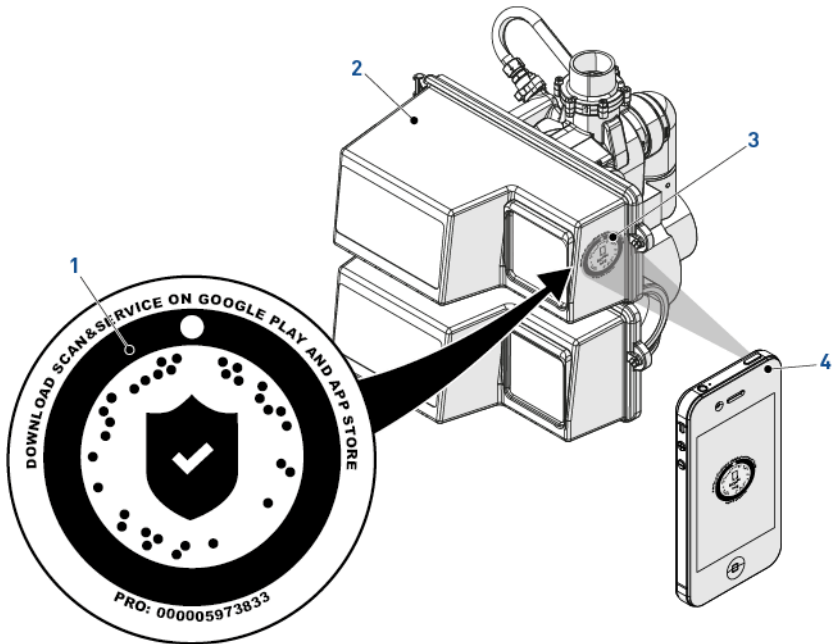

2 Safety

2.1 Safety pictograms definition

DANGER



This combination of symbol and keyword indicates an imminently hazardous situation that will result in serious or fatal injury if not avoided.

WARNING



This combination of symbol and keyword indicates a potentially hazardous situation that can result in serious or fatal injury if not avoided.

CAUTION



This combination of symbol and keyword indicates a potentially hazardous situation that can result in minimal or minor injury if not avoided.

Caution - material



This combination of symbol and keyword indicates a potentially hazardous situation that can result in material damage if not avoided.

Prohibition



Mandatory advice to follow.

Mandatory



Applicable guideline, measure.

Info



Informative comment.

2.2 Serial label location

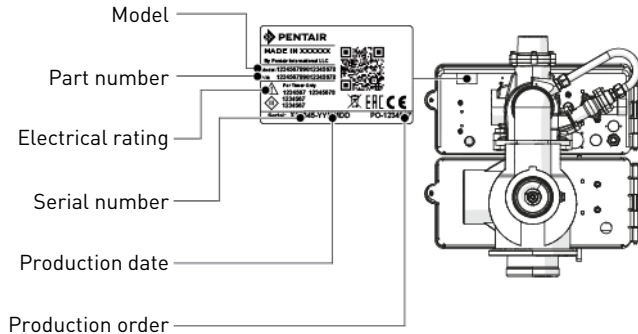

Mandatory



Ensure that the serial label and the safety labels on the device are completely legible and clean !

If necessary, replace them with new labels in the same positions.

2.3 Hazards

All the safety and protection instructions contained in this document must be observed in order to avoid temporary or permanent injury, damage to property or environmental pollution.

At the same time, any other legal regulations, accident prevention and environmental protection measures, as well as any recognized technical regulations relating to appropriate and risk-free methods of working which apply in the country and place of use of the device must be adhered to.

Any non-observation of the safety and protection rules, as well as any existing legal and technical regulations, will result in a risk of temporary or permanent injury, damage to property or environmental pollution.

2.3.1 Personnel



CAUTION



Risk of injury due to improper handling!

Only qualified and professional personnel, based on their training, experience and instruction as well as their knowledge of the regulations, safety rules and operations performed, are authorized to carry out necessary work.

2.3.2 Material

The following points must be observed to ensure proper operation of the system and the safety of user:

- be careful of high voltages present on the transformer (100 – 240 V);
- do not put your fingers in the system (risk of injuries with moving parts and shock due to electric voltage).

2.4 Hygiene and sanitization

2.4.1 Sanitary issues

Preliminary checks and storage

- Check the integrity of the packaging. Check that there is no damage and no signs of contact with liquid to make sure that no external contamination occurred;
- the packaging has a protective function and must be removed just before installation. For transportation and storage, appropriate measures should be adopted to prevent the contamination of materials or the objects themselves.

Assembly

- Assemble only with components which are in accordance with drinking water standards;
- after installation and before use, perform one or more manual regenerations in order to clean the media bed. During such operations, do not use the water for human consumption. Perform a disinfection of the system in the case of installations for treatment of drinking water for human use.

Info



This operation must be repeated in the case of ordinary and extraordinary maintenance. It should also be repeated whenever the system remains idle for a significant time.

Valid only for Italy

In case of equipment used in accordance with the DM25, apply all the signs and obligations arising from the DM25.

2.4.2 Hygiene measures

Disinfection

- The materials used for the construction of our products meet the standards for use with potable water; the manufacturing processes are also geared to preserving these criteria. However, the process of production, distribution, assembly and installation, may create conditions of bacterial proliferation, which may lead to odor problems and water contamination;
- it is therefore strongly recommended to sanitize the products. See Sanitization [▶ Page 121] ;
- maximum cleanliness is recommended during the assembly and installation;
- for disinfection, use Sodium or Calcium Hypochlorite and perform a manual regeneration.

3 Description

3.1 Technical specifications

Design specifications/ratings

Valve body	Brass
Rubber components	EP or EPDM
Weight (valve with controller)	41.0 kg (max)
Recommended operating pressure	1.8 - 8.6 bar
Maximum inlet pressure	8.6 bar
Hydrostatic test pressure	20 bar
Water temperature std	1 - 43°C
Ambient temperature	5 -40°C
Regeneration flow	DF or UF
Bypass of raw water during regeneration:	
Standard	Yes
NBP version	No

Flow rates (3.5 bar inlet - valve only - top mount)

Continuous service flow ($\Delta p = 1$ bar)	57.0 m ³ /h
Peak service flow ($\Delta p = 1.8$ bar)	74.0 m ³ /h
Cv*	65.0 gpm
Kv*	56.4 m ³ /h
Maximum backwash flow ($\Delta p = 1.8$ bar)	24.0 m ³ /h

*Cv: Flow rate in gpm across the valve at a pressure drop of 1 psi at 60°F.

*Kv: Flow rate in m³/h across the valve at a pressure drop of 1 bar at 16°C.

Valve connections

Tank top mounted adapter	6" flanged or 6" thread
Side mount adapter	3" BSP female
Inlet/Outlet	3" BSP female
Distributor pilot	90 mm [DN90]
Drain line	2" BSP
Brine line (1800)	1" NPT male

Electrical

Controller operating voltage	24 VAC for NXT / 24 VDC for NXT2
------------------------------	----------------------------------

Input supply frequency	50 or 60 Hz (controller configuration dependent)
Transformer voltage	24 VAC for NXT / 24 VDC for NXT2
Motor input voltage until March 2019	24 VAC
Motor input voltage April 2019 onwards	24 VDC with AC-DC inverter
Power consumption	105 W
Controller protection rating	IP 22
Valve protection rating	IP 44
Power supply	230 VAC, 50/60 Hz, 60 VA, Class II
Transient overvoltages	within the limits of category II
Pollution Degree	3

Temporary overvoltages must be limited in duration and in frequency.

Model without transformer

CAUTION



Risk of injury due to electrical shock !

A switch or circuit-breaker must be included in the installation, it must be suitably located and easily reached, it must be marked as the disconnecting device for the equipment.

The power must be achieved by a transformer in which the primary windings are separated from the secondary windings by REINFORCED INSULATION, DOUBLE INSULATION, or a screen connected to the PROTECTIVE CONDUCTOR TERMINAL.

It is required the installation of a fuse as overcurrent protection, it has to be positioned between the system and the secondary of the transformer in the installation with the following characteristics: $V \geq 30$ VDC or VAC, $I_{max} = 5.0A$ (ES. 5x20 5.0A)

Environmental conditions

- Indoor use only;
- temperature from 5°C to 40°C;
- maximum relative humidity 80% for temperatures up to 31°C decreasing linearly to 50% relative humidity at 40°C;
- mains supply voltage fluctuations up to $\pm 10\%$ of the nominal voltage.

3.2 Performance flow rate characteristics

The graph shows the pressure drop created by the valve itself at different flow rates. It allows predetermining the maximum flow rate going through the valve depending on the system settings (inlet pressure etc). It also allows to determine the valve pressure drop at a given flow rate, and therefore to evaluate the system pressure drop vs flow rate.

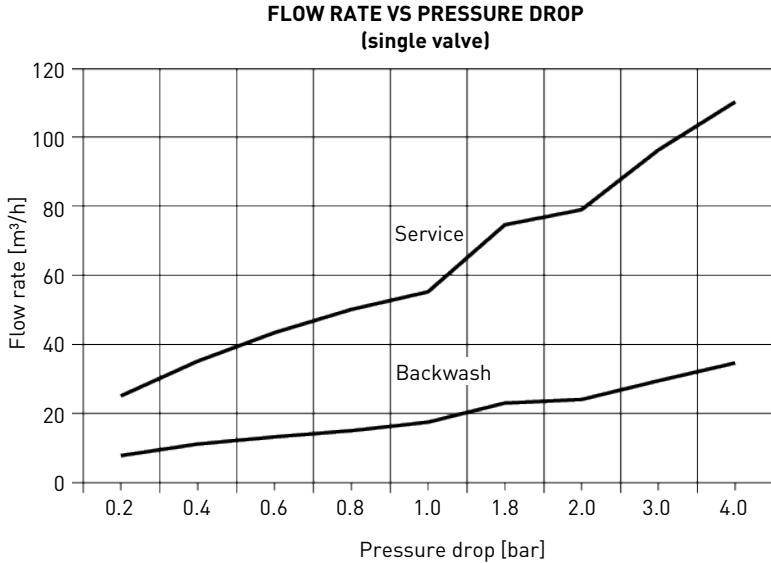

3.3 Outline drawing

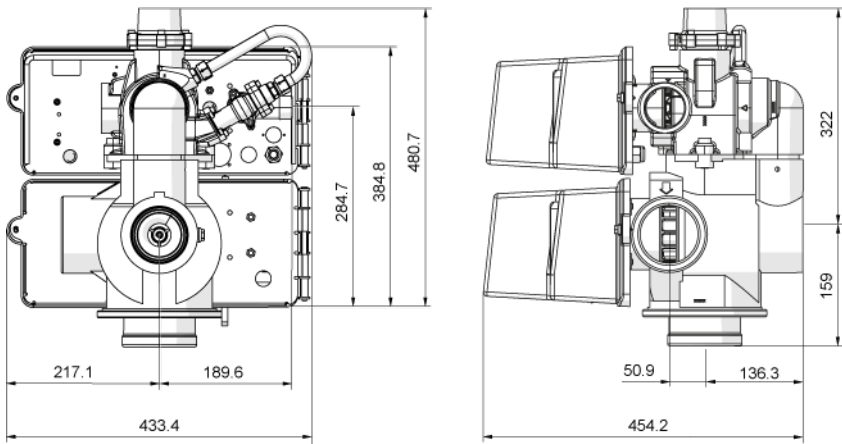

3.4 Components description and location

3.4.1 With NXT controller and AC motor

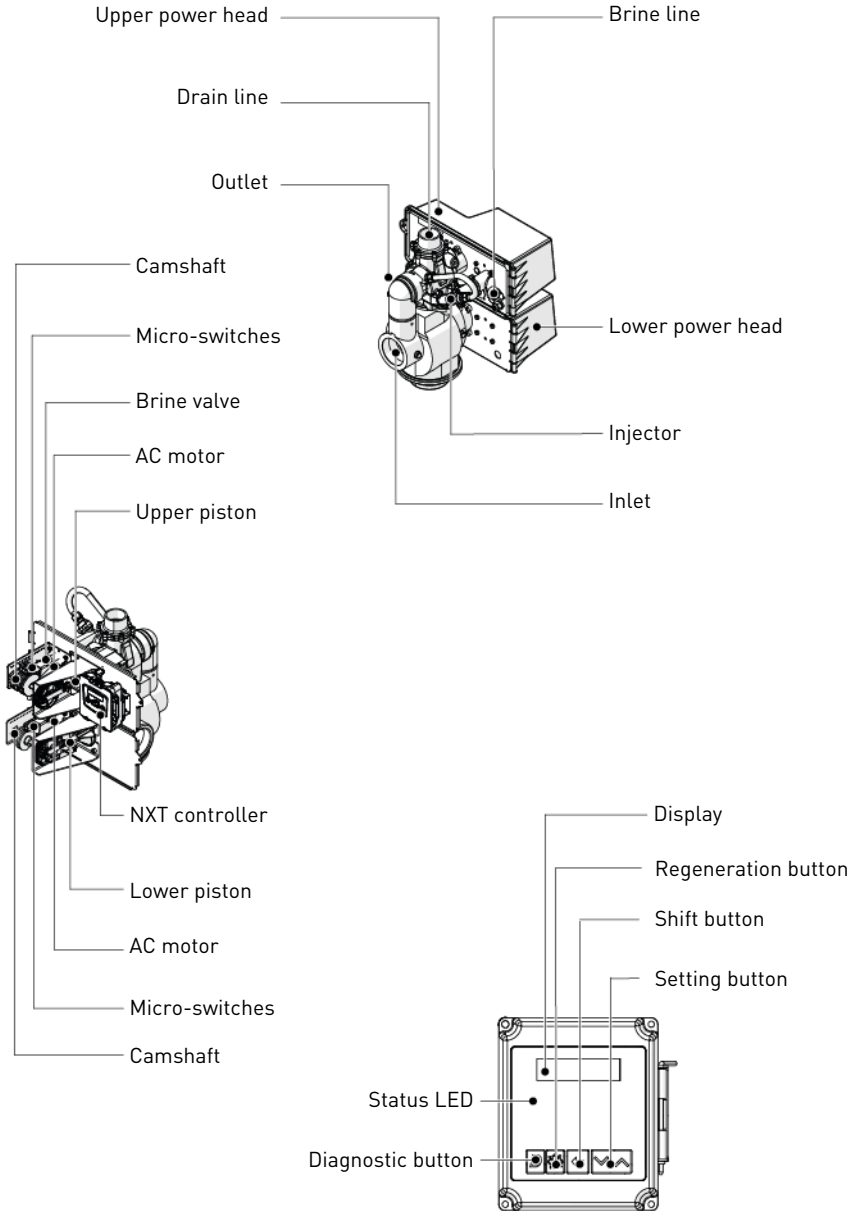

3.4.2 With NXT controller and DC motor

Info



As of April 2019, NXT valves are supplied with 24 VDC motor. This motor is equipped with an AC-DC converter allowing it to be powered with 24 VAC or 24 VDC. Therefore, when used with NXT boards which require 24 VAC power supply and therefore send 24 VAC to the motor, the inverter will convert it into 24 VDC.

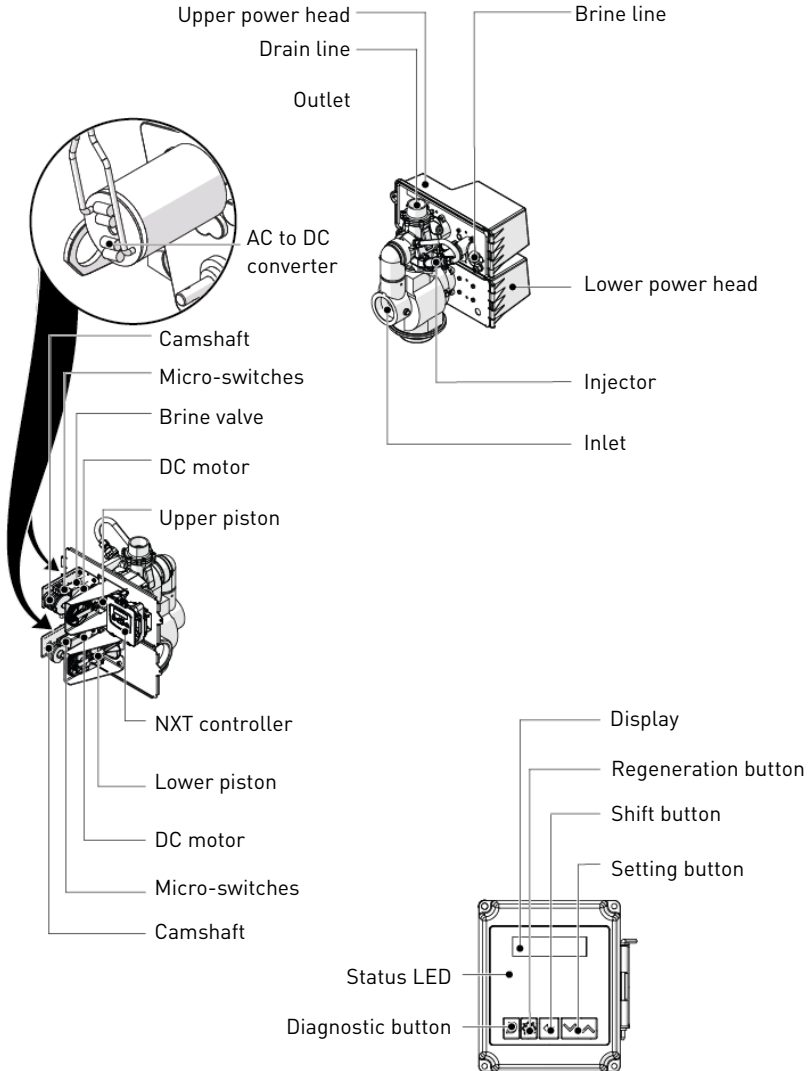

3.4.3 With NXT2 controller and DC motor

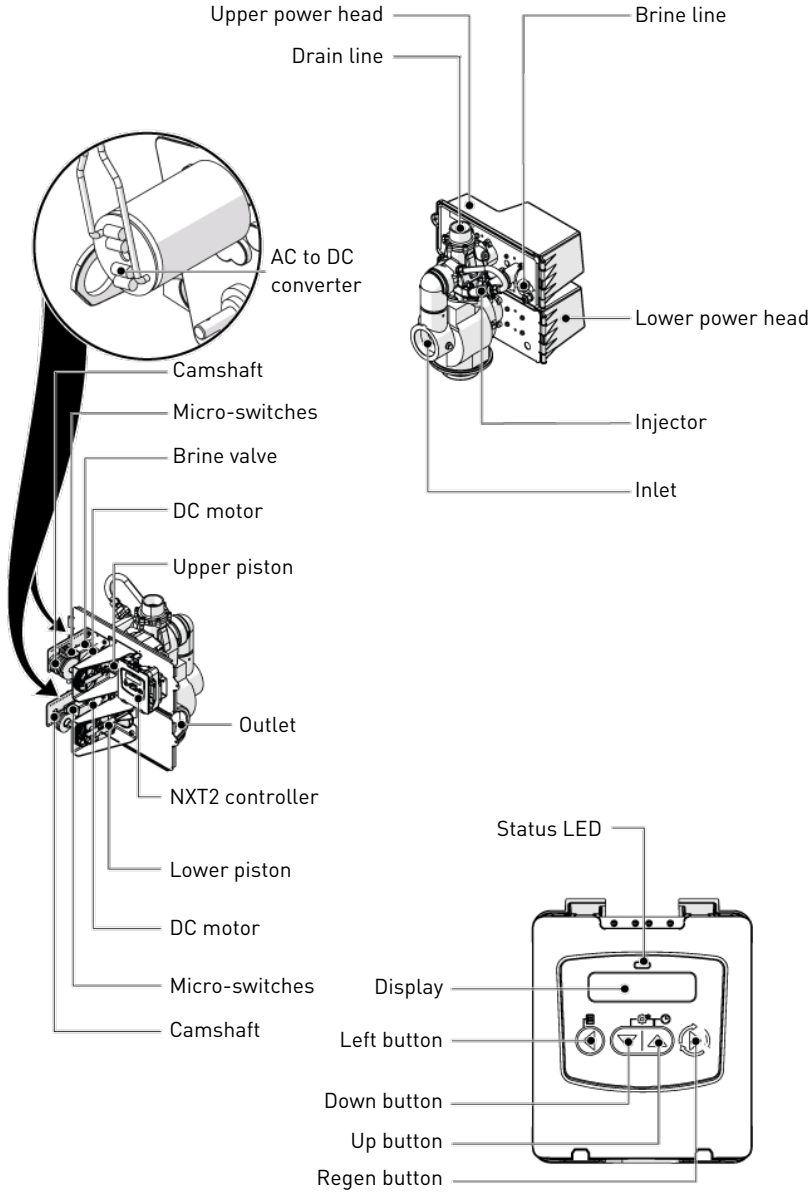

3.5 System regeneration cycle

Info



This valve allows to do filtration, down flow and up flow regenerations.

3.5.1 Downflow regeneration cycle (5-cycles operation)

Service — normal use

Untreated water is directed down through the resin bed and up through the riser tube. The hardness ions attach themselves to the resin and are removed from the raw water being exchanged on the resin beads by sodium ions. The water is conditioned as it passes through the resin bed.

Backwash — cycle C1

The flow of water is reversed by the valve and directed down the riser tube and up through the resin bed. During the backwash cycle, the bed is expanded and debris is flushed to the drain, while the media bed is remixed.

Brine draw & slow rinse — cycles C2

The valve directs water through the brine injector and brine is drawn from the brine tank. The brine is then directed down through the resin bed and up through the riser tube to the drain. The hardness ions on the resin beads are replaced by sodium ions and are sent to the drain. The resin is regenerated during the brine cycle. When the air check valve closes brine drawing finishes, and then the slow rinse phase starts.

Rapid rinse — cycle C3

The valve directs water down through the resin bed and up through the riser tube to the drain. Any residual brine is rinsed from the resin bed, while the media bed is re-compacted.

Brine tank refill — cycle C4

Water is directed to the brine tank, at a rate controlled by the refill controller [BLFC], to create brine for the next regeneration. During brine refill, treated water is already available at the valve outlet.

Pause & Delay — cycle C5

The valve is in stand-by until the end of the cycle. In multiplex, if the brine tank is shared, allows to leave a brine preparation time.

Info



The cycle Pause & Delay is optional with NXT controller. The factory value is set to 0 minute.

Info



For illustration purpose only. Always verify inlet and outlet marking on the valve.

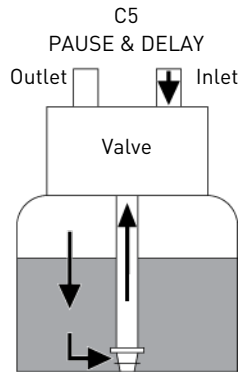
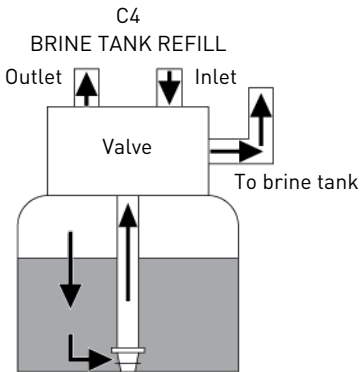
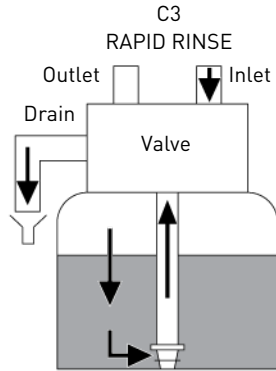
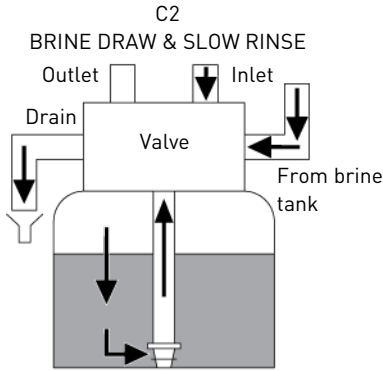
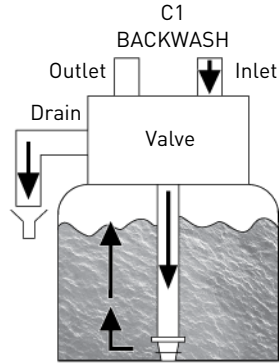
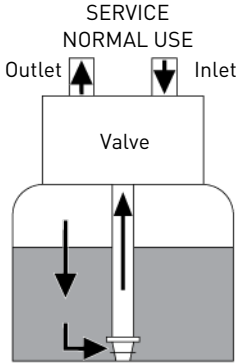

3.5.2 Upflow regeneration cycle (5-cycles operation)

Service — normal use

Untreated water is directed down through the resin bed and up through the riser tube. The hardness ions attach themselves to the resin and are removed from the raw water being exchanged on the resin beads by sodium ions. The water is conditioned as it passes through the resin bed.

Pause & Delay — cycle C1

The valve is in stand-by until the end of the cycle. In multiplex, if the brine tank is shared, allows to leave a brine preparation time.

Info



The cycle Pause & Delay is optional with NXT controller. The factory value is set to 0 minute.

Brine draw & slow rinse — cycles C2

The valve directs water through the brine injector and brine is drawn from the brine tank. The brine is then directed down through the riser tube and up through the resin bed to the drain. The hardness ions are replaced by sodium ions and are sent to the drain. The resin is regenerated during the brine cycle. Then the slow rinse phase starts.

Backwash — cycle C3

The flow of water is reversed by the valve and directed down the riser tube and up through the resin bed. During the backwash cycle, the bed is expanded and debris is flushed to the drain, while the media bed is remixed.

Rapid rinse — cycle C4

The valve directs water down through the resin bed and up through the riser tube to the drain. Any residual brine is rinsed from the resin bed, while the media bed is re-compacted.

Brine tank refill — cycle C5

Water is directed to the brine tank, at a rate controlled by the refill controller, to create brine for the next regeneration. During brine refill, treated water is already available at the valve outlet.

Info



For illustration purpose only. Always verify inlet and outlet marking on the valve.

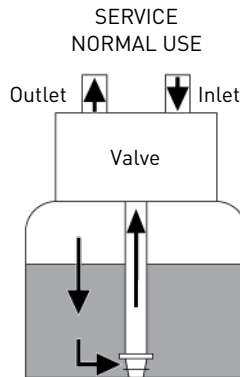
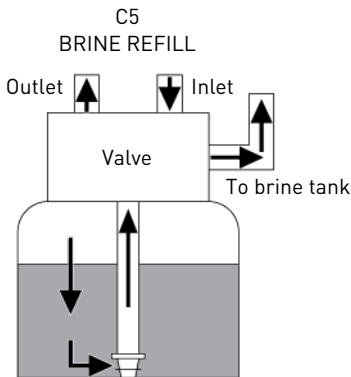
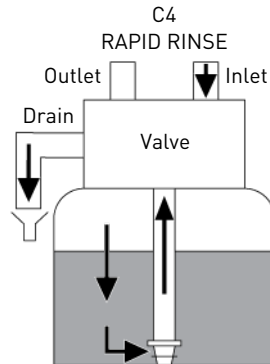
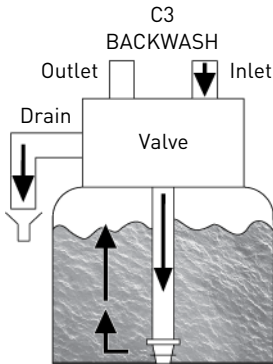
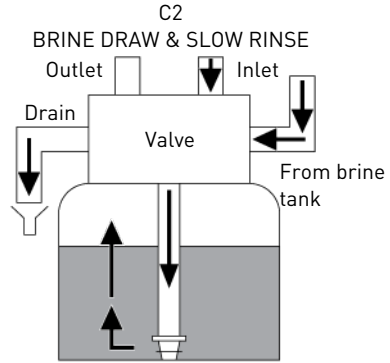
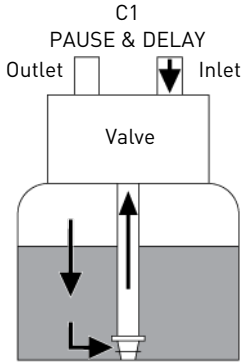

3.5.3 Filter cycle (3-cycles operation)

Service — normal use

Untreated water is directed down through the filter media and up through the riser tube. The impurities are retained by the media. The water is filtered as it passes through the media.

Backwash — cycle C1 for DF configuration, C2 for UF configuration

The flow of water is reversed by the valve and directed down through the riser tube and up through the filter media. During the backwash cycle, the filter bed is expanded and debris is flushed to the drain, while the media bed is remixed.

Rapid rinse — cycle C3 for DF configuration, C4 for UF configuration

The valve directs water down through the filter media and up through the riser tube to the drain. The media bed is getting re-compacted.

Info



For illustration purpose only. Always verify inlet and outlet marking on the valve.

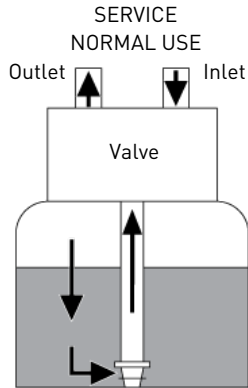
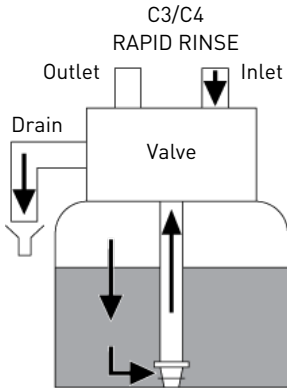
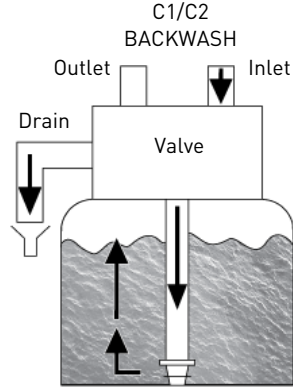
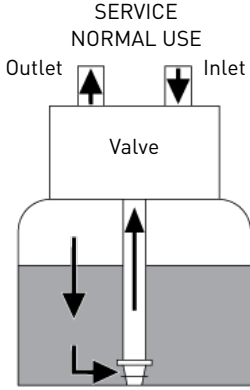

3.6 Injector block position for DF and UF configurations

DF

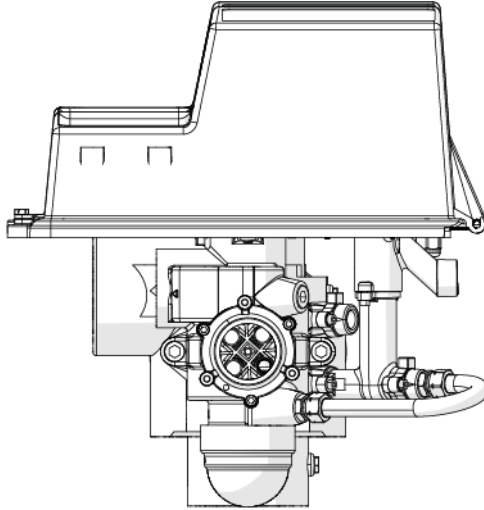

UF

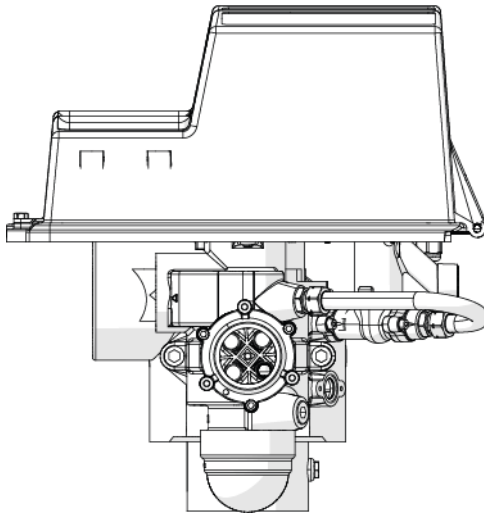

4 System sizing

4.1 Recommended Injector/DLFC/BLFC-Valve configuration

Brine syst.	Tank Diameter	Resin volume L	Injector				DLFC	BLFC	
	[in]		DF	Color	UF	Color	[gpm]	DF [gpm]	UF [gpm]
3900/ 1800	24	283 - 424	4	Green	4	Green	20.0	5.0	5.0
	30	284 - 425	5	Red		25.0			
	36	426 - 605	6	White	5	Red	35.0		
	42	566 - 850	7	Blue	6	White	50.0	10.0	10.0
	48	851 - 1200	8	Yellow	7	Blue	70.0		
	54	1201 - 1550	9	Purple	8	Yellow	80.0		
	60	1551 - 2000	10	Black			100.0		

4.2 Sizing a softener (single unit)

4.2.1 Parameters to be considered

Whenever installing a softener, it is preferable to have full water analysis to ensure the inlet water content will not affect the resin bed.

Tip



Please consult your resin manufacturer specification !

To ensure that no additional pretreatment prior to softening is required.

The below sizing method can be applied for both residential and industrial softeners.

The sizing of a softener must be based upon certain parameters:

- inlet water hardness;
- peak flow rate and nominal flow rate;
- service velocity;
- salt dosage.

The softening and regeneration reactions are driven under certain conditions. To allow these reactions to take place, make sure that the velocity is convenient during the different phases for proper ion exchange. This velocity is given in the resin manufacturer specifications sheet.

Depending on the inlet water hardness, the service velocity for standard softening must be between:

Service velocity [bed volume per hour]	Inlet water hardness [mg/l as CaCO ₃]	°f °TH	°dH
8 - 40	<350	<35	<19.6
8 - 30	350 to 450	35 - 45	19.6 - 25.2

Service velocity [bed volume per hour]	Inlet water hardness [mg/L as CaCO ₃]	°f °TH	°dH
8 - 20	>450	>45	>25.2

Caution - material

Risk of leakage due to unrespected service velocity !

Failure to respect the service velocity will lead to hardness leakage or even total softener inefficiency.

Note that the water supply piping size may also be useful when estimating the nominal flow rate, since the size of the piping allows a maximum flow rate to pass. Assuming the maximum velocity of water in pipes is about 3 m/s, a good estimation for most common pressure [3 bar] and temperature [16°C] is:

Piping size (internal diameter)		Max. flow rate
[in]	[mm]	[m ³ /h at 3 m/s]
0.5	12	1.22
0.75	20	3.39
1	25	5.73
1.25	32	8.69
1.5	40	13.57
2.0	50	21.20
2.5	63	34.2
3.0	75	49.2

4.2.2 Determining the required volume of resin

When sizing a softener, make sure that the volume of resin in the tank (bed volume) will be sufficient so that even when the peak flow rate is reached, the velocity is still between the above values depending on the hardness. When sizing a softener, always choose the resin volume and tank size based on the peak flow rate but not on the nominal flow rate.

Caution - material

Risk of leakage due to wrong sizing !

Sizing on the nominal flow rate without taking the peak flow rate into account would result in choosing smaller tank size and resin volume, and may lead in severe hardness leakage during the service cycle when the peak flow is reached.

The maximum softened water flow rate that a softener can produce is given by the following formula:

$$Q_{\text{service max}} = F_{\text{service}} \times BV$$

with:

$Q_{\text{service max}}$: service flow rate [m³/h]

F_{service} : service velocity [BV/h]

BV: bed volume of resin [m³]

Knowing this required volume of resin, it is possible now to determine the needed tank. Note that at least a third of the total volume of the tank must be kept as free space so that the bed expansion during backwash is sufficient to ensure correct cleaning of the resin.

4.2.3 Resin exchange capacity and capacity of the unit

The resin exchange capacity and capacity of the unit are two different things that should not be confused. The resin exchange capacity is the amount of Ca^{2+} and Mg^{2+} that can be retained by 1 litre of resin, which will depend on the resin type and salt dosage, whereas the capacity of the unit is the capacity of the system, which will depend on the volume of resin and resin exchange capacity.

Knowing the required volume of resin, it is possible to determine the exchange capacity of the unit. The capacity of the unit can be expressed in different ways:

- the mass capacity, which corresponds to the weight in equivalent CaCO_3 that can be fixed on the resin, expressed in kg as CaCO_3 ;
- the volume capacity, which represents the maximum amount of water that can be treated between 2 regenerations. This last capacity takes into account the hardness of the water to be treated and is expressed in m^3 or litre;
- the combined capacity, which represents the volume of water that could be treated between 2 regenerations if the inlet hardness is 1 °f or °dH. This capacity is expressed in °f.m³ or °dH.m³.

The resin exchange capacity will depend on the amount of salt to be injected into the resin bed during the regeneration. This amount of salt is given in grams per litre of resin. The next table is showing the resin exchange capacity in function of the amount of salt for a system with standard efficiency regeneration.

Resin exchange capacity as a function of the salt dosage:

Salt amount [g/L _{resin}]	Corresponding resin exchange capacity in [g/L _{resin}] as CaCO_3	°f.m ³ [per L _{resin}]	°dH.m ³ [per L _{resin}]
50	29.9	2.99	1.67
60	34	3.4	1.9
70	37.5	3.75	2.09
80	40.6	4.06	2.27
90	43.4	4.34	2.42
100	45.9	4.59	2.56
110	48.2	4.82	2.69
120	50.2	5.02	2.8
130	52.1	5.21	2.91
140	53.8	5.38	3.01
150	55.5	5.55	3.1
170	58.5	5.85	3.27
200	62.7	6.27	3.5
230	66.9	6.69	3.74

Salt amount [g/L _{resin}]	Corresponding resin exchange capacity in [g/L _{resin}] as CaCO ₃	°f.m ³ [per L _{resin}]	°dH.m ³ [per L _{resin}]
260	71	7.1	3.97
290	75.3	7.53	4.21

To calculate the system mass capacity:

$$M_{\text{capacity}} = V_{\text{resin}} \times C_{\text{resin ex}}$$

with:

M_{capacity} : system mass capacity [g as CaCO₃]

V_{resin} : volume of resin [L]

$C_{\text{resin ex}}$: resin exchange capacity [g/L_{resin} as CaCO₃]

To calculate the system combined capacity:

$$C_{\text{capacity}} = V_{\text{resin}} \times C_{\text{cor resin ex}}$$

with:

C_{capacity} : system combined capacity [°f.m³ or °dH.m³]

V_{resin} : volume of resin [L]

$C_{\text{cor resin ex}}$: corresponding resin exchange capacity [°f.m³/l or °dH.m³/l]

To calculate the system volume capacity:

$$V_{\text{capacity}} = M_{\text{capacity}} / TH_{\text{inlet}}$$

with:

V_{capacity} : system volume capacity [m³]

Or

M_{capacity} : system mass capacity [g as CaCO₃]

C_{capacity} : system combined capacity [°f.m³ or °dH.m³]

$$V_{\text{capacity}} = C_{\text{capacity}} / TH_{\text{inlet}}$$

TH_{inlet} : inlet water hardness [mg/L as CaCO₃ or °f or °dH]

Mandatory



If a mixing device is set on the valve before meter, use $TH = TH_{\text{INLET}} - TH_{\text{OUTLET}}$!

Having determined the previous capacity allows the operator to know the service cycle duration.

4.2.4 Valve configuration

Knowing the volume of resin, tank size and specifications of the resin, it is possible to determine the required valve configuration. The resin specification will give the backwash velocity, as well as the brine draw and slow rinse velocity that must be respected in order to ensure a proper regeneration of the unit. From this data, determine the required backwash flow rate as well as the brine draw and slow rinse flow rate. In most cases, the fast rinse flow rate will be the same as the backwash flow rate, however for certain valve types the fast rinse flow rate will be the same as the service flow rate.

To determine the backwash flow rate:

$$Q_{\text{backwash}} = F_{S_{\text{backwash}}} \times S$$

with:

Q_{backwash} : backwash flow rate [m³/h]

$F_{S_{\text{backwash}}}$: backwash velocity [m/h]

S: Tank cross section area [m²]

The DLFC installed on the valve has to limit the backwash flow rate to the above calculated flow rate.

To determine the injector size:

The velocities to be respected for brine draw and slow rinse are given on the resin manufacturer specifications. Generally speaking, the injector has to allow a flow rate of about 4BV / h (corresponding to the flow rate of brine being drawn added to the flow rate of raw water passing through the injector nozzle to create the suction effect).

$$Q_{\text{inj}} = 4 \times \text{BV} / \text{h}$$

with:

Q_{inj} : total flow rate passing through the injector [L/h]

BV: bed volume of resin [L]

Info



This value does not correspond to the brine draw flow rate but to the total flow rate passing through the injector.

Refer to the injector diagrams at the inlet pressure in order to check if the injector will give a correct flow rate.

See chapters Salt amount definition [► Page 34] and Injector flow rates [► Page 34].

4.2.5 Cycle time calculation

From this point, the volume of resin, the tank size, the capacity of the softener and the valve configuration are determined. Next step is to calculate the regeneration cycle duration, which depends on the valve configuration and once again on the resin specifications.

Info



Preprogrammed cycle times are only factory default programming that need to be adjusted to fit the system requirements.

For cycle time calculation the valve configuration must be known, which depends on:

- the tank size;
- the resin specifications for the velocity for backwashing the resin bed;
- the velocity of water for brine draw, slow rinse and fast rinse.

Further information needed for cycle time calculation are:

- the resin volume previously determined;
- the salt amount used per regeneration;
- the volume of water to use for backwash, brine draw, slow rinse and fast rinse.

To calculate the backwash duration:

$$T_{\text{backwash}} = (N_{\text{BVbw}} \times \text{BV}) / Q_{\text{DLFC}}$$

with:

T_{backwash} : backwash duration [min]

N_{BVbw} : number of bed volume for backwash

BV: bed volume [L]

Q_{DLFC} : drain line flow controller size [L/min]

Info



The typical value of the volume of water to be used for backwash is between 1.5 and 4 times the bed volume, depending on the inlet water quality.

To calculate the brine draw duration:

Knowing the injector draw flow rate at the working pressure:

$$T_{\text{brine draw}} = V_{\text{brine}} / Q_{\text{draw}}$$

with:

$T_{\text{brine draw}}$: brine draw duration [min]

V_{brine} : brine volume to be drawn [L], see Refill calculation [▶ Page 34].

Q_{draw} : injection draw flow rate [L/min]

Tip



Multiply the amount of salt in kg by 3 to get a approximation of the brine volume to draw !

To calculate slow rinse duration:

The volume of water to be used for slow rinse is given in the resin manufacturers specifications. Generally speaking, it is advised that between 2 and 4 BV of water is used to perform the slow rinse after brine draw. The slow rinse cycle allows brine to be pushed slowly through the resin bed, allowing the resin to be in contact with brine for sufficient time and therefore to be regenerated.

Refer to the injector curve at the common working pressure to determine the slow rinse duration.

$$T_{\text{slow rinse}} = (N_{\text{BVsr}} \times \text{BV}) / Q_{\text{SR}}$$

with:

$T_{\text{slow rinse}}$: slow rinse duration [min]

N_{BVsr} : number of bed volume for slow rinse

BV: bed volume [L]

Q_{SR} : injector slow rinse flow rate [L/min]

To calculate fast rinse duration:

The fast rinse is aimed at eliminating an excess of salt in the resin bed and also recompacting the resin in the tank.

Depending on the valve type, the fast rinse flow rate is controlled by the DLFC or it has about the same flow rate as in service. The fast rinse velocity can be the same as the service velocity, and the volume of water to be used for the fast rinse is generally between 1 and 10 BV depending on the salt dosage.

$$T_{\text{fast rinse}} = (N_{\text{BVfr}} \times \text{BV}) / Q_{\text{DLFC}}$$

with:

$T_{\text{fast rinse}}$: fast rinse duration [min]

N_{BVfr} : number of bed volume for fast rinse

BV: bed volume [L]

Q_{DLFC} : drain line flow controller size [L/min]

To calculate the refill duration:

The refill flow rate is controlled by the refill controller (BLFC). The relation between the BLFC size, the tank size and the resin volume is given in the valve specifications.

To calculate the refill duration:

$$T_{\text{refill}} = V_{\text{WB}} / Q_{\text{BLFC}}$$

with:

T_{refill} : refill duration [min]

V_{WB} : Volume of water to be refill to prepare the brine [L]

Q_{BLFC} : BLFC size [L/min]

$$V_{\text{WB}} = D_{\text{Salt}} \times \text{BV} / S_{\text{sol}}$$

with:

V_{WB} : Volume of water to be refill to prepare the brine [L]

D_{Salt} : Salt dosage per litre of resin [g/L]

BV: Bed volume [L]

S_{sol} : 360g/L - Solubility of salt per litre of water

Tip



When calculating the time required to draw the brine, take into account that the volume of brine [Vbrine] will be 1.125 bigger than the volume of water refilled !

4.3 Salt amount definition

The salt settings are controlled through the controller programming. See Resin exchange capacity and capacity of the unit [▶ Page 30].

4.4 Injector flow rates

The following tables and graphics represent the injectors flow rate as a function of the inlet pressure for the different injector sizes.

4.4.1 1800 Injector flow rates

INJECTOR 5

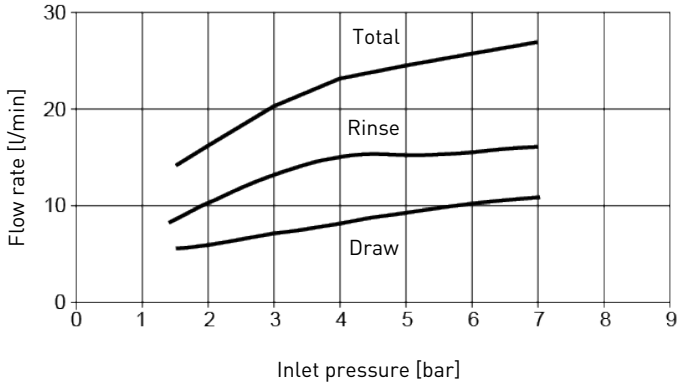

INJECTOR 6

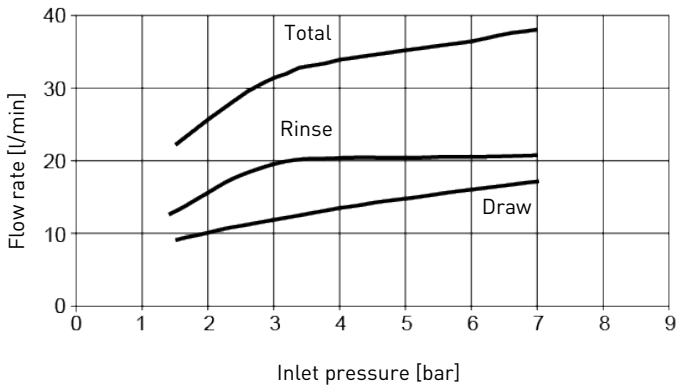

INJECTOR 7

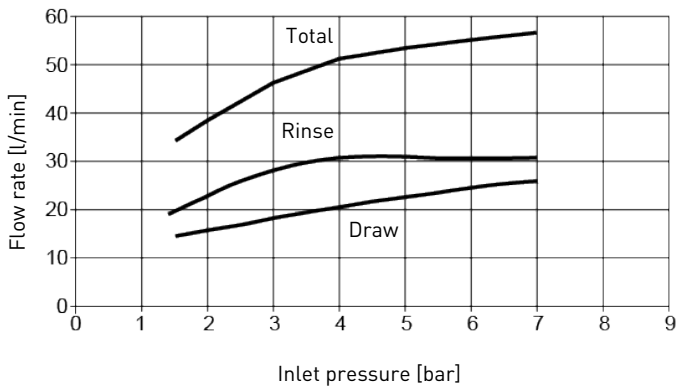

INJECTOR 8

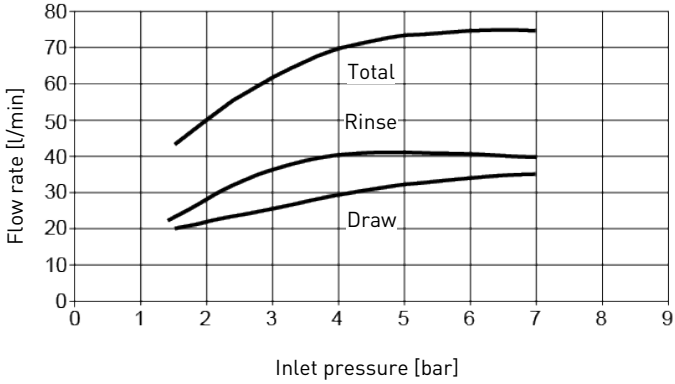

INJECTOR 9

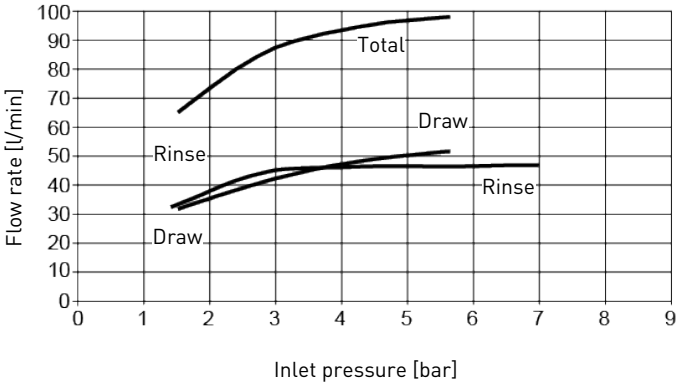

INJECTOR 10

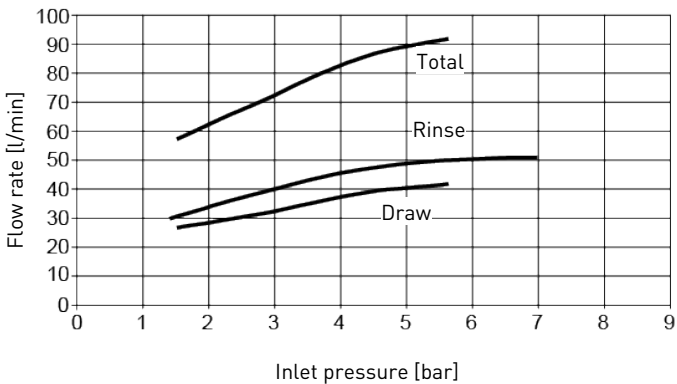

5 Installation

CAUTION



Risk of injury due to electrical shock or pressurized elements !

It is strictly forbidden for not qualified personal, to accede to system's internal parts to perform any kind of technical action.

Be sure to disconnect the electrical power, close the water inlet and depressurize the system before opening the front cover to access internal parts !

5.1 Warnings

The manufacturer will not be held liable for any damages to people or properties resulting from an improper use of the device not compliant with the following instructions.

Whenever this guide doesn't clarify all doubts about installation, service or maintenance, please contact the technical support of the company that has installed the device.

Device installation must be done by a qualified technician according to the current standards and regulations, using tools compliant with a device for a safety use and referring to that technician also for device maintenance.

In case of out of order or malfunction, before performing any kind of action on the device, please ensure to have disconnected the transformer from the power source, to shut off inlet water supply to the valve and to drain water pressure opening a tap down-line of the valve.

1. Be careful when removing the valve from the box and during subsequent handling, weight is liable to cause damage to property and persons in case of accidental impact.
2. Before sending the water on the valve, make sure that all plumbing connections are tight and properly implemented in order to avoid dangerous leaks of pressurized water.
3. Use caution when installing welded metal piping near the valve, the heat may damage the plastic body of the valve and the bypass.
4. Be careful not to let the full weight of the valve on fittings, pipes or bypass.
5. Make sure that the environment in which the valve is installed does not reach freezing temperatures of the water, the valve may be damaged.
6. Make sure that the tank containing the resin is vertical; otherwise the resin could enter in the valve and damage it.

5.2 Safety notices for installation

- Observe all warnings that appear in this manual;
- only qualified and professional personnel are authorized to carry out installation work.

5.3 Installation environment

5.3.1 General

- Use only brine salts designed for water softening. Do not use ice melt, block, or rock salts;

- keep the media tank in an upright position. Do not turn on its side, upside down, or drop it. Turning the tank upside down may cause media to enter the valve or might clog the upper screen;
- follow State and local codes for water testing. Do not use water that is micro-biologically unsafe or of unknown quality;
- when filling the media tank, first place the valve in the backwash position, then partly open the valve. Fill the tank slowly to prevent media from exiting the tank;
- when installing the water connection (bypass or manifold), first connect to the plumbing system. Allow heated parts to cool and cemented parts to set before installing any plastic parts. Do not get primer or solvent on O-rings, nuts, or the valve.

5.3.2 Water

- Water temperature must not exceed 43°C;
- a minimum of 1.8 bar of water pressure is required for the regeneration valve to operate effectively.

Mandatory



Do not exceed a maximum of 8.6 bar inlet pressure. In such cases, it is necessary to install a pressure regulator upstream the system.

5.3.3 Electrical

There are no user-serviceable parts in the AC/AC or AC/DC transformer, motor, or controller. In the event of a failure, these should be replaced.

- All electrical connections must be completed according to local codes;
- use only the power AC/AC or AC/DC transformer that is supplied;

Mandatory



The use of any other power transformer than the one supplied void the warranty of all electronic parts of the valve !

- the power outlet must be grounded;
- to disconnect power, unplug the AC/AC or AC/DC transformer from its power source;
- an uninterrupted current supply is required. Please make sure that the voltage supply is compatible with the unit before installation;
- make sure the controller power source is plugged in;
- if the electrical cable is damaged, it is imperative that it is replaced by a qualified personnel.

5.3.4 Mechanical

Caution - material



Risk of damage due to wrong lubricant use !

Do not use petroleum-based lubricants such as vaseline, oils, or hydrocarbon-based lubricants.

Use only approved silicone grease or soapy water !

- All plastic connections should be hand-tightened. PTFE (plumber's tape) may be used on connections that do not use an O-ring seal. Do not use pliers or pipe wrenches;
- existing plumbing should be in a good shape and free from limescale. In case of doubt, it is preferable to replace it;
- all plumbing must be completed according to local codes and installed without tension or bending stresses;
- soldering near the drain line should be done before connecting the drain line to the valve. Excessive heat will cause interior damage to the valve;
- do not use lead-based solder for sweat solder connections;
- the riser tube should be cut from 12 mm above the top of the tank to 19 mm below the top of the tank. Slightly bevel the ridge in order to avoid deterioration of the seal whilst fitting the valve;
- the drain line must be a minimum of 25.4 mm (1") in diameter;
- do not support the weight of the system on the valve fittings, plumbing, or the bypass;
- it is not recommended to use sealants on the threads. Use PTFE (plumber's tape) on the threads of the drain elbow, and other NPT/BSP threads;
- the installation of a pre-filter is always recommended (100µ nominal);
- valve inlet/outlet must be connected to main piping via flexible.

5.4 Integration constraints

Location of a water treatment system is important. The following conditions are required:

- flat and firm level platform or floor;
- room to access equipment for maintenance and adding brine (salt) to tank;
- constant electrical supply to operate the controller;
- total minimum pipe run to water heater of 3 m (10 ft) to prevent backup of HW into system;
- always install check valve before water heater to protect the softener from HW return;
- local drain for discharge as close as possible;
- water line connections with shut off or bypass valves;
- must meet any local and state codes for site of installation;
- valve is designed for minor plumbing misalignments. Do not support weight of system on the plumbing;
- be sure all soldered pipes are fully cooled before attaching plastic valve to the plumbing.

5.5 Valve connection to piping

The connections should be hand tightened using PTFE (plumber's tape) on the threads if using the threaded connection type.

In case of heat welding (metal type connection), the connections should not be made to the valve when soldering.

Tip



See chapter Components description and location [Page 18] to identify the connections.

When pressurized, any composite tank will expand both vertically and circumferential. In order to compensate the vertical expansion, the piping connections to the valve must be flexible enough to avoid overstress on the valve and tank.

5.5.1 Top-mounted valve installation

The valve and tank should not be supporting any part of the piping weight. This is hence compulsory to have the piping fixed to a rigid structure (e.g. frame, skid, wall...) so that the weight of it is not applying any stress on the valve and tank.

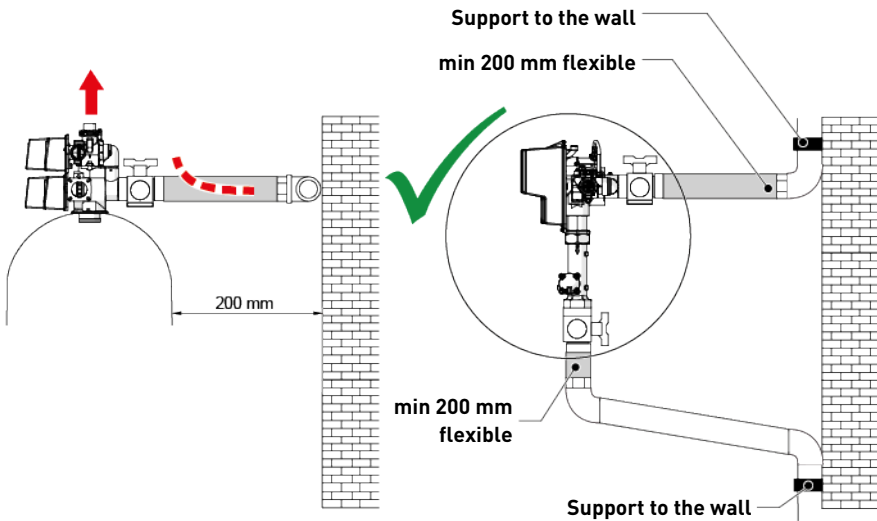

- The diagrams above illustrate how the flexible piping connection should be mounted;
- in order to adequately compensate the tank elongation the flexible tubes must be installed **horizontally**;
- should the flexible piping connection be installed in vertical position, instead of compensating the elongation, it will create additional stresses on the valve & tank assembly. Therefore this is to be avoided;
- the flexible piping connection must also be installed stretched, avoiding excessive length. For instance 20 – 40 cm is enough;

- excessively long and non-stretched flexible piping connection will create stresses on the valve and tank assembly when the system is pressurized, as illustrated in the below picture: on the left the assembly when the system is unpressurized, on the right the flexible piping connection when put under pressure tends to lift up the valve when stretching up. This configuration is even more dramatic when using semi-flexible piping;
- failure to provide enough vertical compensation may lead to different kinds of damage, either on the valve thread which is connected to the tank, or on the female thread connection of the tank. In some cases, damage may also be seen on the valve inlet and outlet connections;



- in any case, any failure caused by improper installations and/or piping connections may void the warranty of Pentair products;
- in the same way, using lubricant* [▶ Page 41] on the valve thread is not allowed and will void the warranty for the valve and tank. Indeed using lubricant there will cause the valve to be over-torqued, which may lead to valve thread or tank thread damage even if the connection to piping has been done following the above procedure.

*Note: Use of petroleum-based grease and mineral based lubricant is totally forbidden, not only on the valve thread, since plastics used (especially Noryl) will highly suffer from contact with this type of grease, leading into structural damage hence to potential failures.

5.5.2 Side-mounted valve installation

Valid for location having a reduced height.

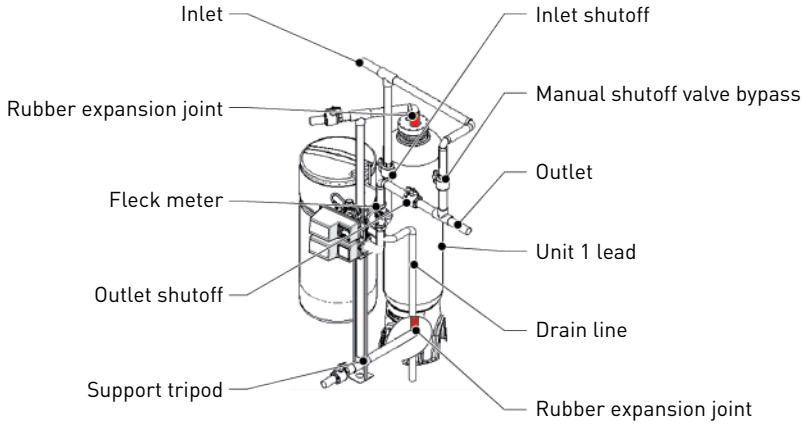

- To avoid the piping supporting the valve and side adapter weight, they must be fixed on a tripod or any other appropriate support;
- in order to adequately compensate the tank elongation, the rubber expansion joints must be mounted on the top and bottom of the tank. In red on the diagram above.

5.6 Block diagram and configuration example

Block diagram

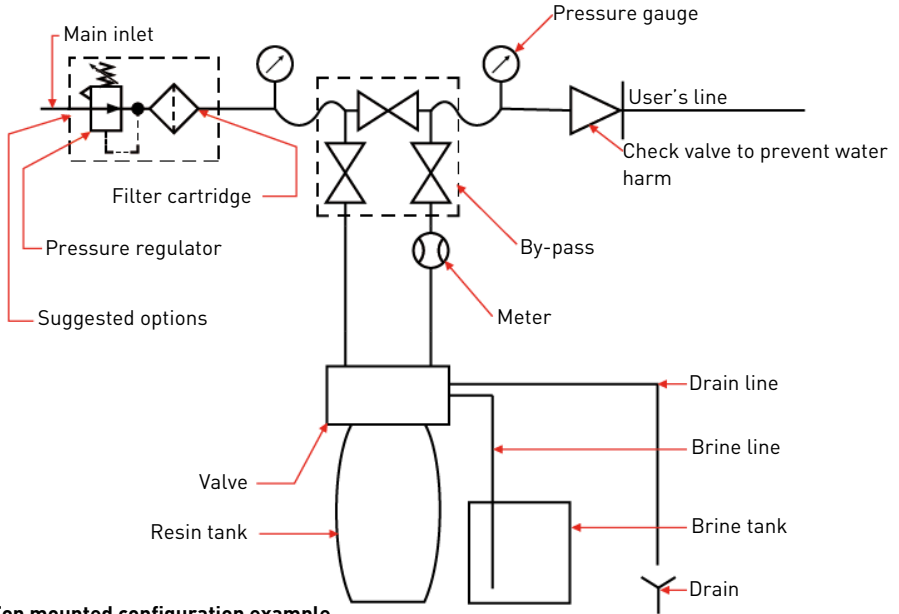

Top mounted configuration example

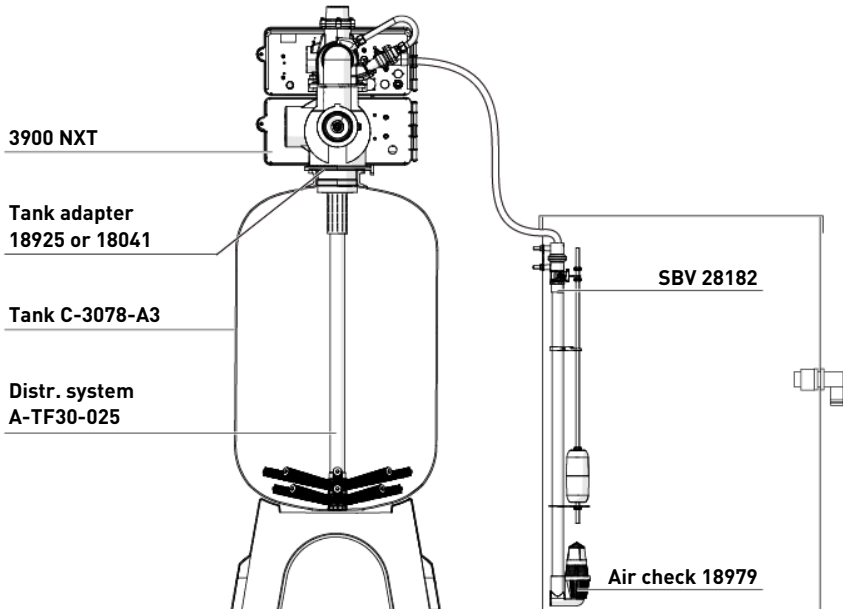

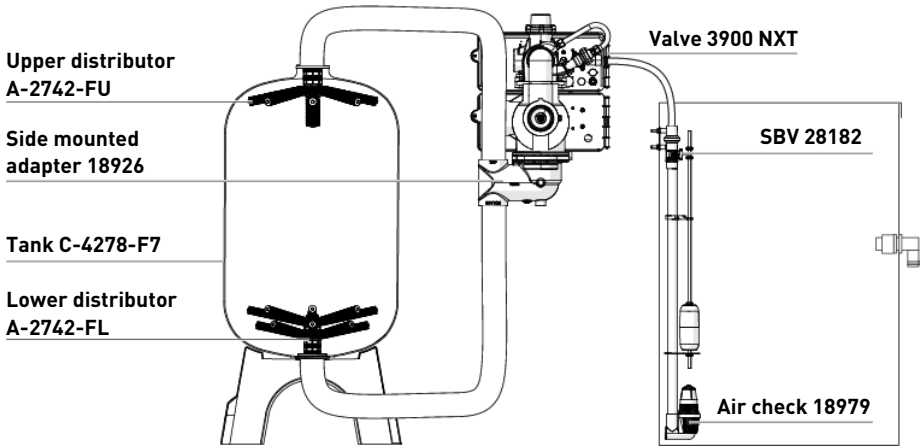

5.7 Regeneration flows

Mandatory



For all multiple tank systems NBP valve version must be used !

Info



In this chapter, systems up to four valves are used to describe and illustrate the different multiple valves systems, even if the described system may control more than four valves.

Metered immediate:

The controller monitors the volume of water used. As soon as the capacity is exhausted, the controller starts the regeneration process.

Metered delayed:

The controller monitors the volume of water used. When the remaining capacity is less than the programmed reserve, the controller queues a regeneration that will start at the programmed regeneration time.

Time clock:

The controller initiates the regeneration at regular preset time interval at the programmed regeneration time.

Remote regen start:

The controller initiates the regeneration when an external dry signal is acquired on the S2 terminal (see Electrical connections [▶Page 53], signal must last at least the programmed signal duration).

For NXT2 controller only

Day of the week

The controller initiates the regeneration at the programmed regeneration time on preset day(s) of the week.

5.7.1 Single valve (System 4)

As named, this system works with only one valve. The regen can be initiated upon the treated volume (delayed or immediate), time clock mode or an external remote regen signal or day of week (NXT2 controller only).

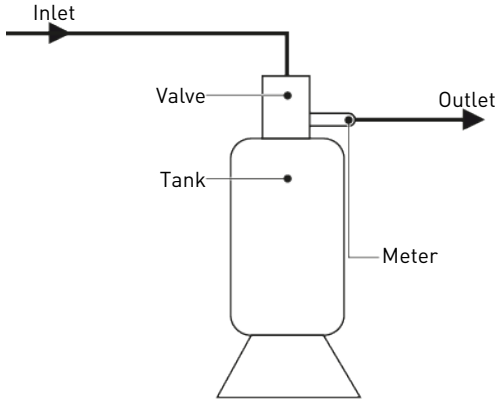

5.7.2 Multiple valves, parallel interlock system (System 5)

This system type may be used to build systems from 2 to 4 valves for NXT controller, 2 to 8 valves for NXT2. Each valve must be equipped with a water meter.

All tanks in parallel are supplying treated water. Each unit in the system has its own flow meter. The controller will delay the start of regeneration if another unit is already regenerating. Once that unit has completed a regeneration cycle and returned to service, the unit with longest regeneration queue time will begin regeneration. Only one unit regenerates at the time. Automatic regeneration may be triggered by either volumetric mean or external dry contact.

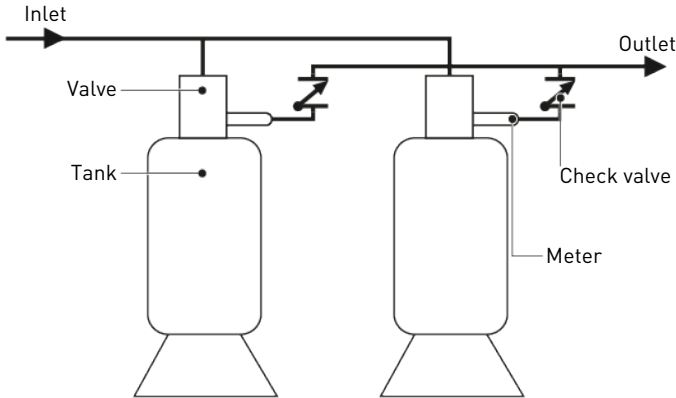

5.7.3 Multiple valves, parallel series regeneration system (System 6)

This system type may be used to build systems from 2 to 4 valves for NXT controller, 2 to 8 valves for NXT2. Only One water meter is required for the whole system.

During normal operation, the controllers of each valve display the time of day and the volume of water remaining. The remaining volume is the total volume of the system. The remaining volume displayed drops with water consumption to reach zero. When this happens, if no other valve is regenerating, the lead valve starts regeneration while sending out a regeneration lock out signal to all other valves of the system. If another valve is regenerating, the valve will stay in service until the other goes back in service. As soon as the lead valve finishes its regeneration cycle, the second valve starts regenerating, then the third, etc. The regenerating valve keeps on sending a regeneration lock out signal to all other valves of the system. A manual regeneration can only be done on the lead valve and only if the others are not regenerating. Automatic regeneration may be triggered by either volumetric mean or external dry contact.

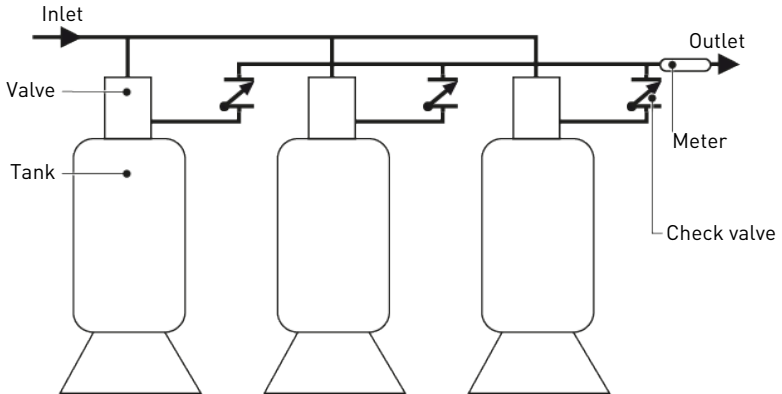

5.7.4 Duplex alternating immediate system (System 7)

This system works with 2 valves and a meter.

During normal operation, the controller of each valve displays the time of day and the remaining volume. The remaining volume displayed drops with water consumption to reach zero. When this happens, the regeneration starts immediately. The valve in service sends a signal to the valve in standby that goes in service. Once this occurs, the valve with exhausted capacity starts its regeneration process.

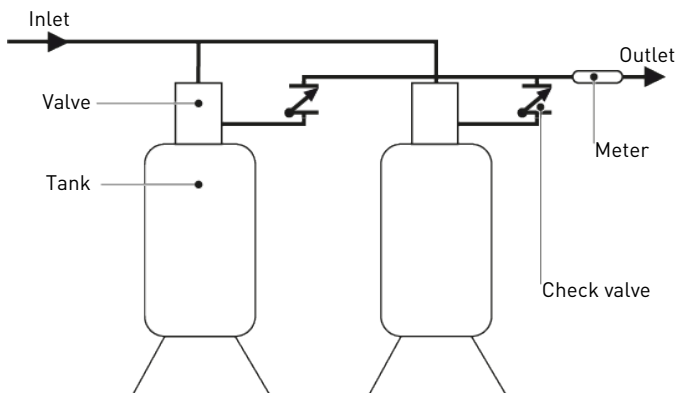

5.7.5 Duplex alternating delayed system (System 8) (NXT2 only)

This system works with 2 valves and a meter.

During normal operation, the controller of each valve displays the time of day and the volume of water remaining. The remaining volume displayed drops with water consumption to reach zero. When this happens, the valve in service books a regeneration that will start at the programmed regeneration time. When the programmed regeneration time is reached, the valve in service sends a signal to the valve in standby that moves into service position. Once the 2nd valve is in service, regeneration of the exhausted valve starts.

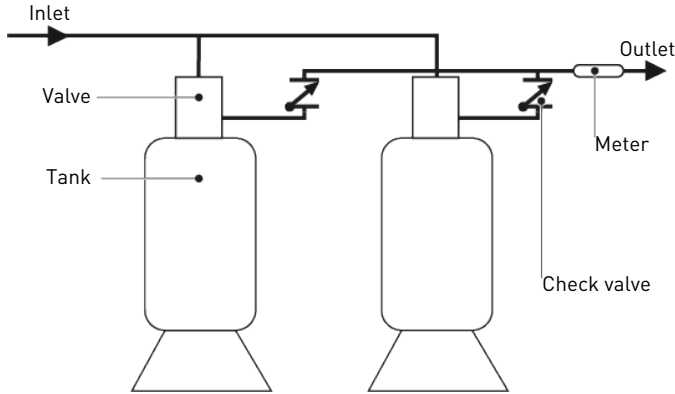

5.7.6 Multiple valves, parallel system with standby unit (System 9)

This system type may be used to build systems from 2 to 4 valves for NXT controller, 2 to 8 valves for NXT2. Each valve must be equipped with a water meter.

One to three tanks in service (NXT) or one to seven tanks in service (NXT2) supplying treated water, one tank in standby. The regeneration of an exhausted unit can start only after the unit in standby has returned to service position. When the regeneration cycle is complete, the regenerated unit will enter in standby. Standby on each tank is controlled by the drive output terminals [24 VAC or 24 VDC, see UDM on Electrical connections [▶Page 53]] on the NXT/NXT2 circuit board.

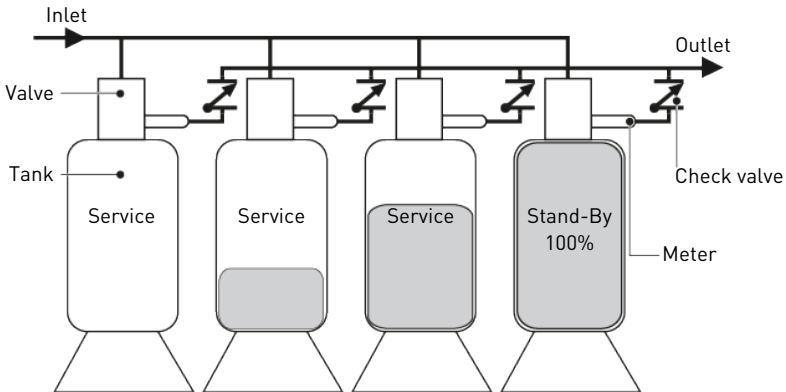

5.7.7 Multiple valves, system on-demand (System 14)

This system type may be used to build systems from 2 to 4 valves for NXT controller, 2 to 8 valves for NXT2. Each valve must be equipped with a water meter.

The number of tanks in service depends on the flow rate and on programmed settings.

5.7.7.1 Examples of a four units system

1. One tank is in service at all time (the "primary tank").

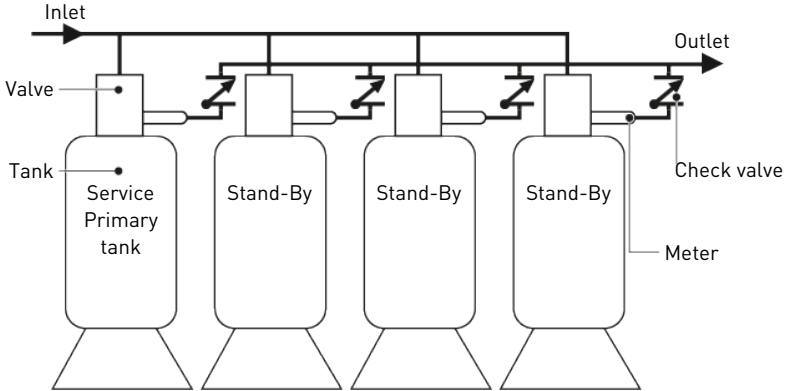

2. The total flow rate to the primary tank increases and exceeds the first programmed trip point. The flow rate demand stays above the trip point for the preset delay time. The next tank (with the least remaining volume) changes from standby into service. This then splits the total flow between two meters.

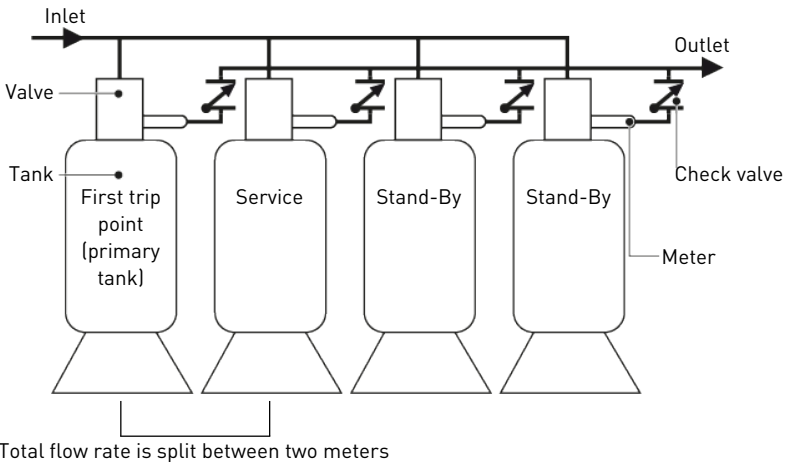

3. The flow rate demand decreases below the first trip point. The tank returns to standby.

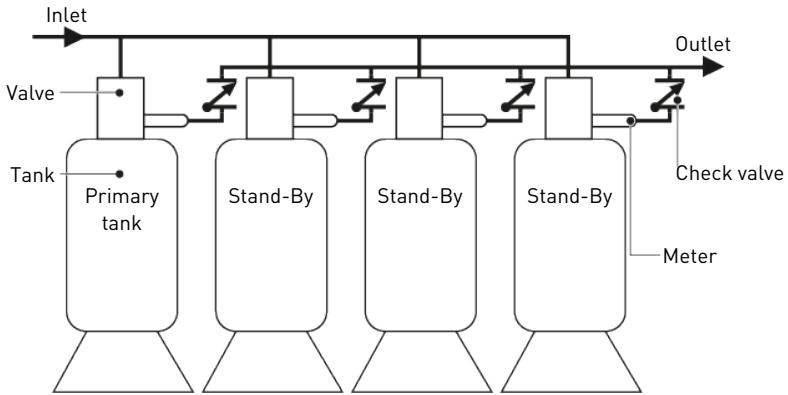

Total flow rate demand below first trip point

4. Total flow rate demand increases and exceeds the second trip point for a longer period than the programmed delay time. The second and third tank (with the least remaining volumes) change from standby to service. The total flow is split between three meters.

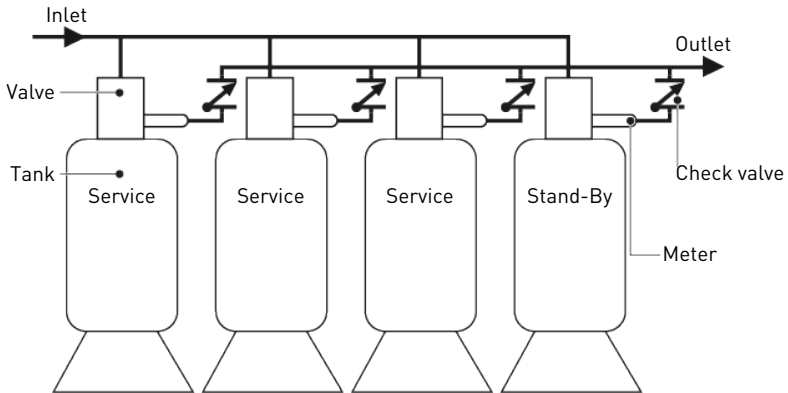

Total flow rate is split between three meters

5. The third tank returns to standby as demand decreases and returns below the second trip point.

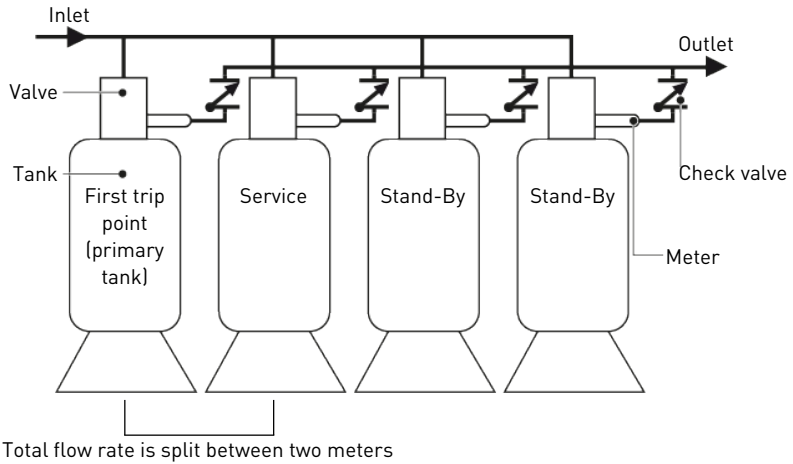

6. Tanks return to standby due to decreased total flow rate and programmed trip points. The tank with the most remaining volume will be the first to go into standby.

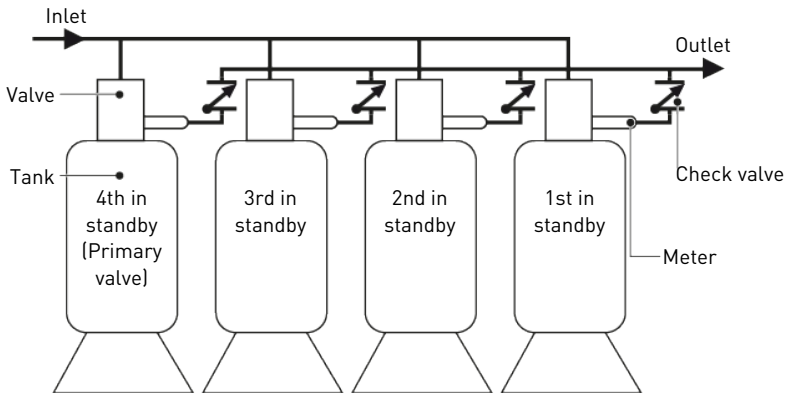

5.7.7.2 System operation in regeneration

The primary tank regenerates when its remaining volume becomes zero. The next tank with the least remaining volume becomes the new primary tank. The tank with the next least volume remaining will be the first to be activated when the flow rate reach the programmed trip point. Tanks continue operating in this order.

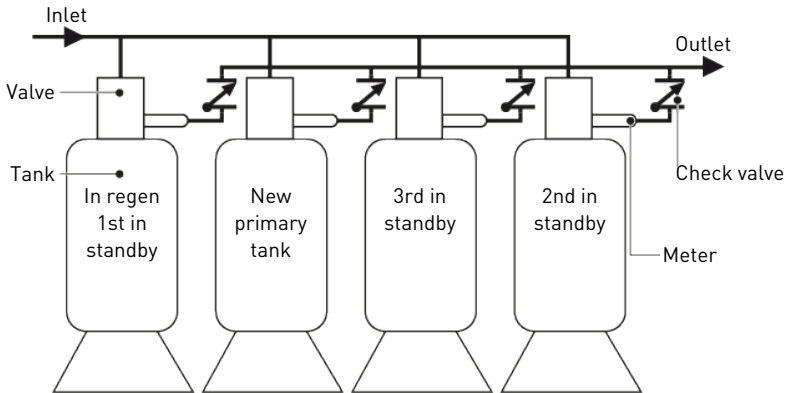

If two tanks are in service and both becomes exhausted at the same time, the other two tanks will shift from standby into service. The lead tank with exhausted capacity will start regeneration. The second tank with exhausted capacity will enter into standby. If the flow increases and exceed the trip point, a third tank must move into service position. The tank in standby with exhausted capacity will shift into service to maintain a steady flow. Operating for extended periods in this mode may degrade the water quality.

5.8 Electrical connections

CMN:	Common	STRT:	Remote regen start
FM:	Flow meter	SV:	Solenoid valve
GND:	Ground	Sw1:	Upper piston switch
HCAM:	Upper piston cam	Sw2:	Brine valve switch
LCK:	Remote regen lock	Sw3:	Lower piston switch
LDCAM:	Lower piston cam	UDM:	Upper power head motor
LDM:	Lower power head motor	W1:	Black wire
NC:	Normally closed	W2:	Red wire
NO:	Normally open	W3:	Brown wire
RST:	Reset button	W4:	Yellow wire
S1:	Inhibition signal (when contact is closed)	W5:	White wire
S2:	Remote regen signal start (when contact is closed)	W6:	Blue wire
S3:	External signal during service or regeneration	W7:	Orange wire
S4:	Dry contact switch function	W8:	Violet wire
S5:	Relay (5A 30 VDC - 10A 250 VAC)	W9:	Green wire
SCAM:	Brine valve cam	W10:	Black and white wire

5.8.1 NXT controller connections

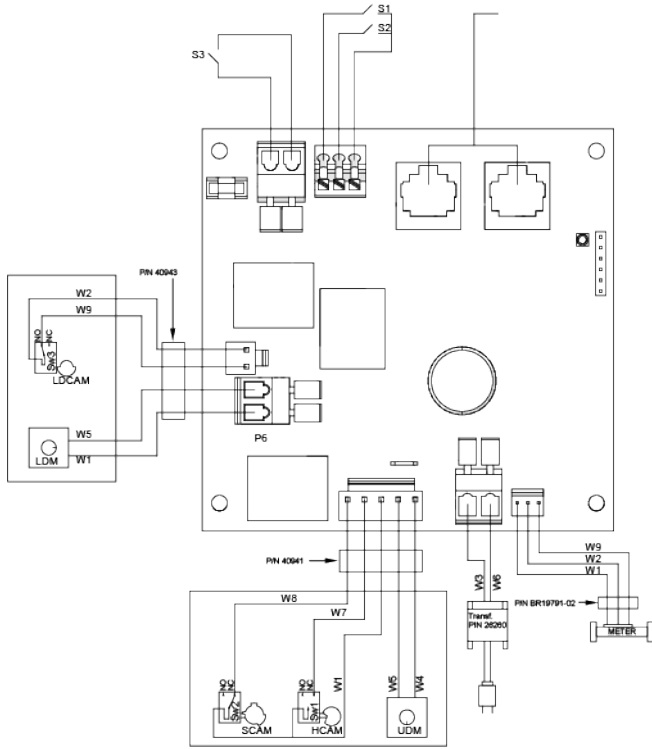

5.8.2 NXT2 controller connections

Caution - material



Risk of damage due to wrong connection !

Do not connect 24V (AC or DC) power supply on the Lower piston switch connector P17, as this would immediately and irreversibly damage the electronic board.

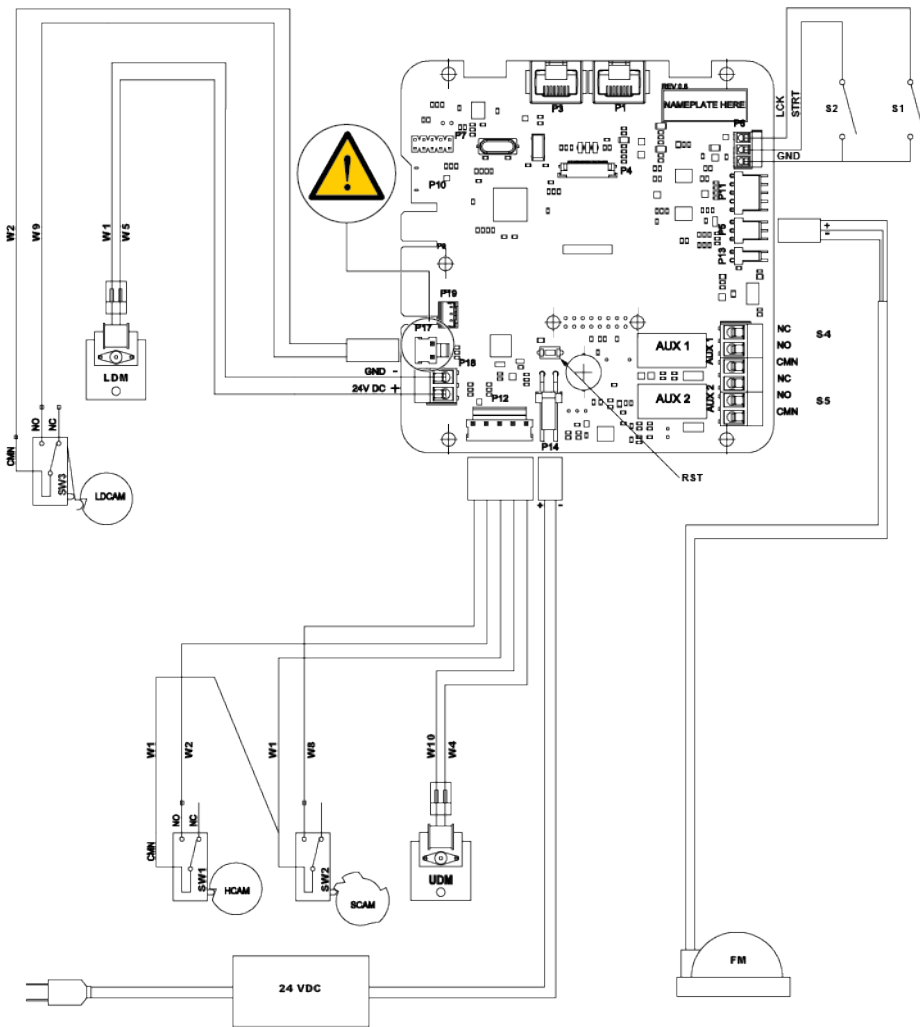

5.8.3 NXT controller connections for multiple valves

2 controllers NXT

Duplex system 5, 6, 7, 9 & 14

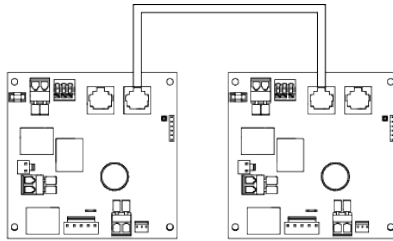

3 controllers NXT

Triplex system 5, 6, 9 & 14

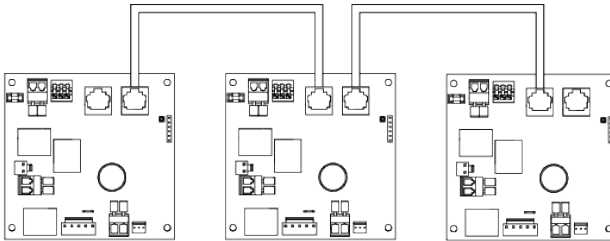

4 controllers NXT

Quadriplex system 5, 6, 9 & 14

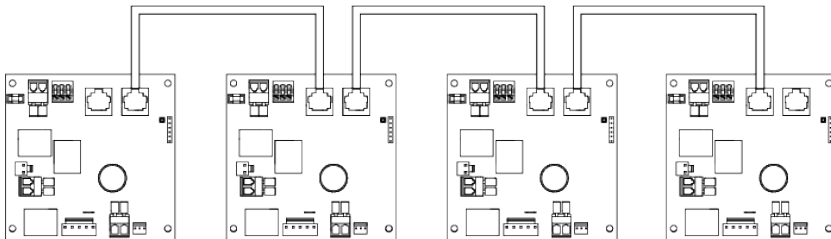

Info



The valve with address #1 must not be at the left or right extremity of the system in order to ensure proper information communication in between the 4 valves of the system.

5.8.4 NXT2 controller connections for multiple valves

Mandatory



Use CAT5 (with RJ45 connector) or better twisted pair cables with a maximum length of 30 meters !

2 controllers NXT2

Duplex system 5, 6, 7, 8, 9 & 14

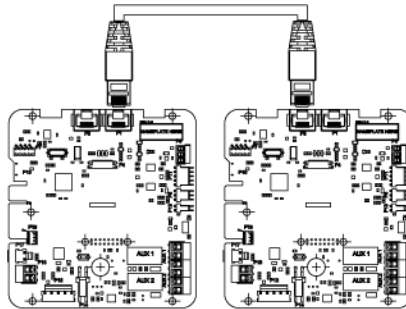

3 controllers NXT2

Triplex system 5, 6, 9 & 14

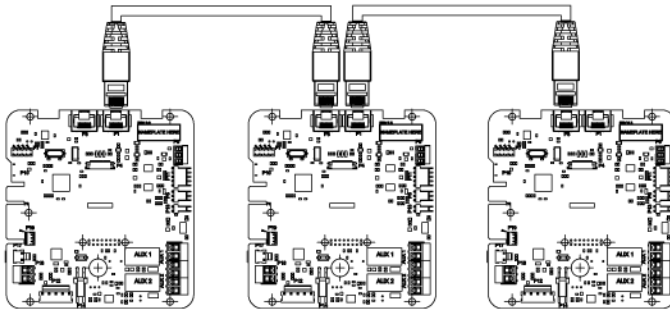

4 to 8 controllers NXT2

Multiplex system 5, 6, 9 & 14

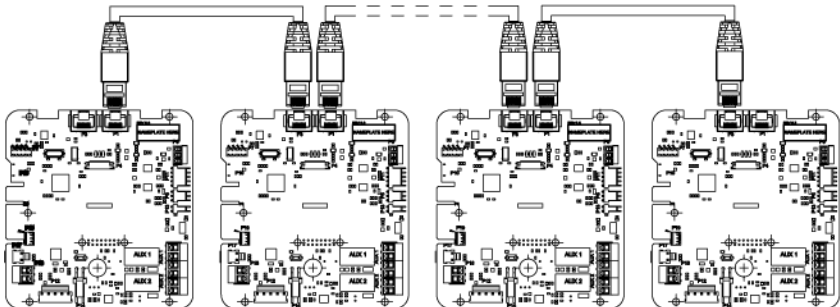

5.9 Bypassing

A bypass valve system should be installed on all water conditioning systems. Bypass valves isolate the softener from the water system and allow unconditioned water to be used. Service or routine maintenance procedures may also require that the system is bypassed.

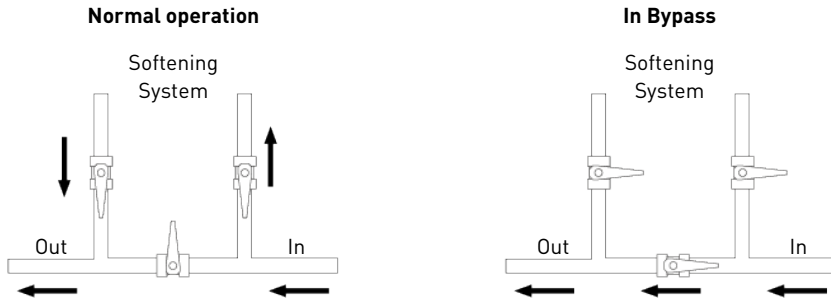

Caution - material



Risk of damage due to bad mounting !

Do not solder pipes with lead-based solder.

Do not use tools to tighten plastic fittings. Over time, stress may break the connections.

Do not use petroleum grease on gaskets when connecting bypass plumbing. Use only 100% silicone grease products when installing any plastic valve. Non-silicone grease may cause plastic components to fail over time.

5.10 Drain line connection

Info



Standard commercial practices are expressed here.

Local codes may require changes to the following suggestions.

Check with local authorities before installing a system.

Mandatory



The drain line must be build with 2" PVC rigid tube ! An air gap must be present at the drain !



CAUTION



Risk of injury due to whipping hose !

Flexible and semi-flexible hoses may bend and whip during draining.

The drain line may be elevated up to 1.8 m provided the run does not exceed 4.6 m and water pressure at the softener is not less than 2.76 bar. Elevation can increase by 61 cm for each additional 0.69 bar of water pressure at the drain connector.

Where the drain empties into an overhead sewer line, a sink-type trap must be used.

Secure the end of the drain line to prevent it from moving.

Mandatory



Waste connections or the drain outlet shall be designed and constructed to provide connection to the sanitary waste system through an air-gap of 2 pipe diameters or 100.6 mm (4"), whichever is larger.

Caution - material



Risk of damage due to lack of gap !

Never insert the drain line directly into a drain, sewer line or trap. Always allow an air gap between the drain line and the waste water to prevent the possibility of sewage being back-siphoned into the softener.

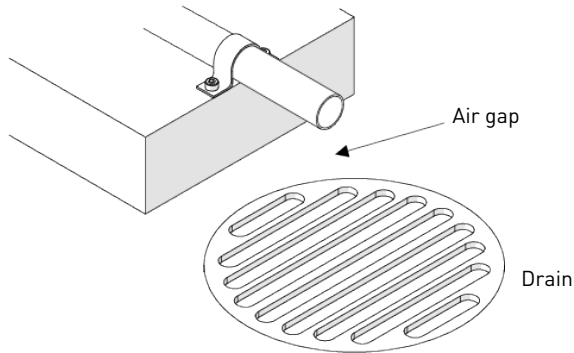

5.11 Overflow line connection

In the event of a malfunction, the brine tank overflow fitting will direct “overflow” to the drain instead of spilling on the floor. This fitting should be on the side of the brine tank. Most brine tank manufacturers feature a pre-drilled hole for the tank overflow connector.

To connect the overflow line, locate the hole on the side of the tank. Insert the overflow fitting into the tank and tighten with plastic thumb nut and gasket as shown below. Attach a 25.4 mm (1") I.D. tubing (not supplied) to fitting and run to drain.

Do not elevate overflow higher than overflow fitting.

Do not tie into the drain line of the controller unit. The overflow line must be a direct, separate line from overflow fitting to drain, sewer or tub. Allow an air gap as per drain line instructions.

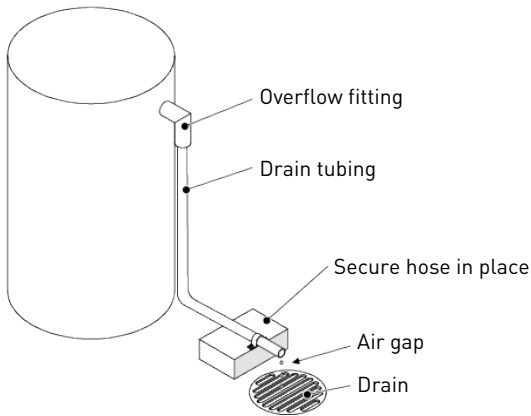

Caution - material



Risk of flooding due to lack of floor drain !

Floor drain is always recommended to avoid flooding in case of overflow.

5.12 Brine line connection

Mandatory



The brine line must be built with 1" PVC rigid tube !

Caution - material



Risk of malfunction due to the use of wrong equipment !

Flexible and semi-flexible hoses may shrink because of the vacuum during brine draw.

The brine line from the tank connects to the valve. Make the connections and hand tighten. Be sure that the brine line is secure and free from air leaks. Even a small leak may cause the brine line to drain out, and the softener will not draw brine from the tank. This may also introduce air into the valve, causing problems with the valve operation.

Brine line must be equipped with brine tank air check in the brine tank.

6 Programming

6.1 NXT controller

6.1.1 Display

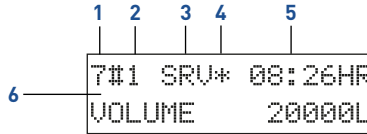

1. System type
 - 4: single valve;
 - 5: Multiple valves, parallel interlock system, 2 to 4 valves;
 - 6: Multiple valves, parallel series regeneration system, 2 to 4 valves;
 - 7: duplex alternating immediate system, 2 valves;
 - 9: Multiple valves, parallel system with standby unit, 2 to 4 valves;
 - 14: Multiple valves, system on-demand, 2 to 4 valves.
2. Valve address
 - #-: single valve;
 - #1: address 1, lead valve;
 - #2: address 2;
 - #3: address 3;
 - #4: address 4.
3. Valve status
 - CHG (change of state): lower drive changes position on double piston valve;
 - INI (initializing): after a power failure or a change in the programming, the controllers initializes for approximately 30 seconds;
 - RGQ (regeneration queued): in a meter delayed system, the reserve capacity has been entered or a manual regeneration has been registered;
 - LCK (lock): the controller has acquired the lockout signal;
 - SRV (service): valve in service;
 - SBY (standby): valve in standby.
4. Flow indicator
 - rotates when flow is going through the meter.
5. Time of the day
 - time of the day in AM/PM or 24 hours mode.
6. Operating mode
 - remaining volume in volumetric mode;
 - remaining days before regeneration in timeclock mode.

6.1.2 Commands

Info



At any time, press **D** to return to the home screen without saving.

Menus are displayed in a defined and incremental order.

If none of the buttons are pushed for 5 minutes in the Programming mode, or if there is a power failure, the controller returns to Service mode without saving.

Mandatory



In order to store the new settings in the programming mode, it is necessary to go through all the parameters !

1. Press to pass to the next step.
2. Use to move the cursor to the next digit.
3. Use and adjust the values.
4. Press **D** at any time to exit programming mode without saving.

6.1.3 Setting the time of the day

Set the time in the system.

Mandatory



In multiple valve systems, set the time of day on the lead valve (#1). !

The time of day will be automatically updated on the other valves in the system within 10 seconds.

Info



If, during time setting, no buttons are pushed for 5 seconds, the system leaves setting.

1. Press or for 2 seconds.
2. Set the controller with , and .
3. Press to validate the selection and return to the service mode.

SET TIME OF DAY:
08:43HR

6.1.4 Basic programming

6.1.4.1 Basic programming mode chart

Parameter	Options	Definition	Note
LANGUAGE	ENGLISH	English	-
	FRANCAIS	French	
	DEUTSCH	German	
	ITALIANO	Italian	
	ESPANOL	Spanish	

Parameter	Options	Definition	Note
FEED WATER HARDNESS	1 to 1'999	Milligram CaCO ₃ /L	This screen will only display on the lead unit for system types 6 & 7. For all other system types, it will display for all units.
REGENERATION DAY OVERRIDE	OFF to 99	Day.	Use the SHIFT button to move to the left.
REGENERATION TIME	00:00:00 to 23:59:59	Hour	Regeneration time will not appear unless regeneration day override or timeclock is on.

6.1.4.2 Language setting

Select the displayed language.

Options:

- English;
- French;
- German;
- Italian;
- Spanish.

1. Press and simultaneously for 5 seconds to enter the menus sequence.
2. Select the language to be displayed with and .
3. Press to validate the selection and advance to the next parameter.

```
SELECT LANGUAGE:
ENGLISH
```

6.1.4.3 Inlet water hardness

Set the inlet water hardness in the unit defined on chapter Display format [▶Page 71].

1. Set the inlet water hardness with , and .
2. Press to validate the selection and advance to the next parameter.

```
FEED WATER
HARDNESS: 0030mgL
```

6.1.4.4 Regeneration days override

Set the maximum number of days that the valve is in service without regenerating, regardless from the volume of water used.

Mandatory



For a timeclock valve, this value must be set !

Info



For metered valves, calendar override parameter would trigger a regeneration only if the volumetric control did not start a regeneration before calendar override period elapsed.

Each volumetric regeneration happening reset the calendar override delay.

1. Adjust the number of days with , and .
2. Press to validate the selection and advance to the next parameter.
 - ⇒ Can be adjusted from:
 - 1 to 99 days for timeclock regeneration;
 - OFF to 99 days for metered regeneration.

Without calendar override.

```
REGENERATION DAY
OVERRIDE: OFF
```

override every 3 days.

```
REGENERATION DAY
OVERRIDE: 03DAYS
```

6.1.4.5 Regeneration start time

Set the time for regeneration start.

Mandatory



Must be set when the regeneration flow programmed is timeclock or with a metered calendar override !

1. Adjust the time of regeneration with , and .
2. Press to validate the selection and return to service.

Regeneration at 2:00 am.

```
REGENERATION
TIME      02:00HR
```

6.1.5 Master programming mode

Info



As soon as programming mode is entered, all parameters can be displayed or set to suit the needs.

Depending on the current programming, some functions will not be displayed or will not be changeable.

6.1.5.1 Master programming mode chart



Parameter	Options	Definition	Note
LANGUAGE	ENGLISH	English	-
	FRANCAIS	French	
	DEUTSCH	German	
	ITALIANO	Italian	
	ESPANOL	Spanish	

Parameter	Options	Definition	Note
SYSTEM TYPE	4	Single unit	1 unit.
	5	Parallel interlock	2 to 4 units.
	6	Parallel series regeneration	
	7	Alternating immediate	2 units.
	9	Parallel with standby unit	2 to 4 units.
	14	On-demand	
VALVE ADDRESS	#1	First control valve	This screen will not be displayed for system type 4.
	#2	Second control valve (default)	
	#3	Third control valve	
	#4	Fourth control valve	
SYSTEM SIZE	2	2 valves in the system	This screen will not be displayed for system type 4.
	3	3 valves in the system	
	4	4 valves in the system	
REGEN TYPE	TIME CLK DELAYED	Time clock delayed (default)	System 4 only.
	METER IMMEDIATE	-	All system types.
	MTR DLY FIX RSV	Metered delayed fixed reserve	Systems 4 & 6 only.
VALVE TYPE	2750	-	-
	2850	-	
	2900/2910	-	
	3150	-	
	3900	-	
	STAGER-NOTCH CAM	-	
REGENERANT FLOW	DOWN FLOW	-	-
	UP FLOW	-	
REMOTE SIGNAL START	OFF to 99 minutes	-	This screen will not be displayed for system type 14.
DISPLAY FORMAT	US-GALLONS	US units (default)	-
	EU-METRIC-LITRES	Metric units	
UNIT CAPACITY	1 to 198'000	Gram CaCO ₃	Use the SHIFT button to move to the left.
CAPACITY SAFETY FACTOR	0 to 50	%	

Parameter	Options	Definition	Note
FEED WATER HARDNESS	1 to 1'999	Milligram CaCO ₃ /L	This screen will only display on the lead unit for system types 6 & 7. For all other system types, it will display for all units. Use the SHIFT button to move to the left.
TRIP POINT 1	1 to 3997	L/m	This screen will only display for system 14 and will only appear on the master controller (Valve address #1). Use the SHIFT button to move to the left.
TRIP DELAY 1	30 to 99	Second (30 seconds default)	
TRIP POINT 2	1 to 3997	L/m	This screen will only display for system 14 and will only appear with the system sized to 3 or 4 on the master controller (Valve address #1). Use the SHIFT button to move to the left.
TRIP DELAY 2	30 to 99	Second (30 seconds default)	
TRIP POINT 3	1 to 3997	L/m	This screen will only display for system 14 and will only appear with the system sized to 4 on the master controller (Valve address #1). Use the SHIFT button to move to the left.
TRIP DELAY 3	30 to 99	Second (30 seconds default)	
REGENERATION DAY OVERRIDE	OFF to 99	Day	Days between regenerations for timeclock mode.
REGENERATION TIME	00:00:00 to 23:59:59	Hour	Regeneration time will not appear unless regeneration day override or timeclock is on.
CYCLE 1	OFF to 04:00:00		-
CYCLE 2	OFF to 04:00:00		-
CYCLE 3	OFF to 04:00:00		-
CYCLE 4	OFF to 04:00:00		-
CYCLE 5	OFF to 04:00:00		This screen will only display when cycle 4 is not OFF.
AUXILIARY RELAY	Enabled	-	Not compatible with CPO AUX activation.
	Disabled	{Default}	

Parameter	Options	Definition	Note
AUX RELAY OUTPUT START	00:00:00 to 18:00:00	Hour	Only displayed if auxiliary relay is enabled in previous screen.
AUX RELAY OUTPUT END	00:00:00 to 18:00:00		Auxiliary relay will only display if chemical pump is OFF for system types 6 & 7.
CHEMICAL PUMP	Enabled	-	This screen will only display on the lead (#1) unit for system types 6 & 7. For all other system types, it will display for all units.
	Disabled	(Default)	
CPO AUX RELAY VOLUME	1 to 9'999	L	Activate the relay output during a service based upon the volume of treated water. Relay is activated for a set time after every set volume is treated. Not compatible with aux. relay activation.
CPO AUX RELAY TIME	00:00:00 to 02:00:00	Hour	
FLOW METER	1.0" PADDLE	-	Default flow meter type is based on the valve type.
	1.0" TURBIN E	-	
	1.5" PADDLE	-	This screen will only display on the lead (#1) unit for system types 6 & 7.
	1.5" TURBIN E	-	
	2.0" PADDLE	-	All other system types it will display for all units.
	3.0" PADDLE	-	
	GENERIC	-	
PEAK FLOW RATE	20 to 2'000	l/min	Only displayed if "Generic" is chosen for the flow meter.
ADD XXX LITRES EVERY YYY PULSES	1 to 255	XXX: number of litre/ gallon YYY: number of pulses	

6.1.5.2 Entering master programming mode

- Press  and  simultaneously for 5 seconds to enter the master programming mode.

```

7#1 SRV* 08:26HR
VOLUME 20000L
  
```



6.1.5.3 Language setting

Select the displayed language.

Options:

- English;
- French;
- German;

- Italian;
- Spanish.

1. Select the language to be displayed with  and .
2. Press  to validate the selection and advance to the next parameter.



```
SELECT LANGUAGE:
ENGLISH
```

6.1.5.4 System type

Select the system in which the valve(s) operate(s).

Options:

- 4: single valve;
- 5: multiple valves, parallel interlock system;
- 6: multiple valves, parallel series regeneration system;
- 7: duplex alternating immediate system;
- 9: multiple valves, parallel system with standby unit;
- 14: multiple valves, system on-demand.

1. Set the system type with  and .
2. Press  to validate the selection and advance to the next parameter.

Example: 4 Single valve.

```
SYSTEM TYPE   :4
SIMPLEX
```

Example: 5 multiple valves.

```
5#1 RGO* 10:15HR
VOLUME      3000L
```

6.1.5.5 Valve address in the system

Set the valve position in the system.

Info





Only visible in systems 5, 6, 7, 9 and 14.

The number #1 is the lead valve (master) and contains the programmed parameters used by the other controllers in the system in order to control the regeneration and service or standby positions.

Options:

- address #1: valve 1, lead (master);
- address #2: valve 2;
- address #3: valve 3;
- address #4: valve 4.

1. Set the valve position with  and .
⇒ Default setting: valve 2 address #2.
2. Press  to validate the selection and advance to the next parameter.

Example: Valve #1 (master).

VALUE	ADDRESS
	#1

Example: Valve #2.

VALUE	ADDRESS
	#2

6.1.5.6 System size

Set the number of valves to be connected (2 to 4 valves) in the system.



Info



Only visible in multiple valve systems and only present on the master #1 valve.

Options:

- 2 valves in the system;
- 3 valves in the system;
- 4 valves in the system.

1. Adjust the system size with  and .
⇒ Default setting: 2 valves.
2. Press  to validate the selection and advance to the next parameter.



SYSTEM SIZE	:
	2 VALVES

6.1.5.7 Regeneration type

Select the regeneration type.

Options:

- time clock delayed: regeneration will take place, at the programmed regeneration time, after the set amount of days has been reached (available only for system type 4);
- volume delayed: regeneration is requested when the volume of treated water reaches the reserve capacity and will take place, at the programmed regeneration time (available only for system type 4);
- volume immediate: regeneration is requested when the capacity is fully depleted. The regeneration starts immediately (available for all system types).

1. Set regeneration type with  and .
2. Press  to validate the selection and advance to the next parameter.



REGEN TYPE
TIME CLK DELAYED

6.1.5.8 Valve type

Select which valve is being used with the NXT.

Options:

- 2750;
- 2850;
- 2900/2910;
- 3150;
- 3900.

1. Set valve type at 3900 with  and .

⇒ Default setting: 2750

VALVE TYPE: 3900

2. Press  to validate the selection and advance to the next parameter.

6.1.5.9 Regeneration flow

Set the direction of flow during the brine draw cycle.

Info



The availability depends on the valve type programmed in the previous step.

Options:

- down flow;
- up flow (not for 2850 valve type);
- up flow fill first (only for 2750 and 2900/2910 types).

1. Set regeneration flow with  and .

⇒ Default setting: down flow

REGENERANT FLOW DOWN FLOW

2. Press  to validate the selection and advance to the next parameter.

6.1.5.10 Remote started regeneration





Start regeneration from an external signal (see chapter Electrical connections [»Page 53]).

Info



The contact will close after a preset duration. When the contact closes, the regeneration starts.

This mode can be combined with the other methods of regeneration; it has priority once it is activated.

1. Set the remote controller with ,  and .
⇒ Can be adjusted from OFF to 01:39:00.
2. Press  to validate the selection and advance to the next parameter.

Without remote controller.

```
REMOTE SIGNAL
START: OFF
```

With remote controller and 1 minute contact programmed.

```
REMOTE SIGNAL
START: 00:01:00
```

6.1.5.11 Display format

Set the unit system to be used.

Options:

- US GALLONS: volume in gallons, time display 2 x 12 hours, hardness in grains;
- EU-METRIC-LITRES: volume in litre, time display 24 hours and hardness depends on the language:





EN: mg/L as
CaCO₃

FR: °F

GE: °dH

IT: °TH

SP: °TH

1. Set the display format with ,  and .
2. Press  to validate the selection and advance to the next parameter.





```
DISPLAY FORMAT
EU-METRIC-LITER
```

6.1.5.12 System capacity

Set the capacity of the tank where the valve is installed.

Info

- **Based on system capacity, safety coefficient and inlet water hardness, the controller calculates the volume of water that the system can treat between 2 regenerations.**

1. Set the unit capacity with ,  and .
2. Press  to validate the selection and advance to the next parameter.

Example: 3000 g of CaCO₃ of capacity.

```
UNIT CAPACITY
003000 gCaCO3
```

This volume corresponds to the volume the tank could treat if the inlet water hardness is 1°F, 1°TH or 1°dH.

6.1.5.13 Safety coefficient

Set the percentage value by which the total capacity is reduced as a safety coefficient.

1. Set the safety coefficient with \swarrow , \searrow and \leftarrow .
 ⇒ Can be adjusted from 0 to 50%.
2. Press \otimes to validate the selection and advance to the next parameter.

No safety factor programmed.

```

CAPACITY SAFETY
FACTOR 00%
    
```

6.1.5.14 Inlet water hardness

Set the inlet water hardness in the unit set on chapter Units [▶Page 100]

1. Set the inlet water hardness with \swarrow , \searrow and \leftarrow .
2. Press \otimes to validate the selection and advance to the next parameter.

```

FEED WATER
HARDNESS:0030mgL
    
```

6.1.5.15 Trip points setting

Set the flow rate and switching delay when another tank is switched to service.

Info



Only visible in system 14.

Trip point 1

Info



Only visible if controller programmed as valve position #1.

1. Set the trip point 1 flow rate with \swarrow , \searrow and \leftarrow .
 ⇒ Can be adjusted from 0 to 3997 l/min.
2. Press \otimes to validate the selection and advance to the next parameter.
3. Set the trip point 1 delay with \swarrow , \searrow and \leftarrow .
 ⇒ Can be adjusted from 30 to 99 seconds.
4. Press \otimes to validate the selection and advance to the next parameter.

```

TRIP POINT 1:
0000Lpm
    
```

```

TRIP DELAY 1
30 SECONDS
    
```

Trip point 2

Info



Only visible if controller programmed as valve position #1 and system size to 3 or 4.

1. Set the trip point 2 flow rate with \swarrow , \searrow and \leftarrow .
 ⇒ Can be adjusted from trip point 1+1 to 3998 l/min.
2. Press \otimes to validate the selection and advance to the next parameter.
3. Set the trip point 2 delay with \swarrow , \searrow and \leftarrow .
 ⇒ Can be adjusted from 30 to 99 seconds.
4. Press \otimes to validate the selection and advance to the next parameter.

```
TRIP POINT 2:
      0000Lpm
```

```
TRIP DELAY 2
      30 SECONDS
```

Trip point 3

Info



Only visible if controller programmed as valve position #1 and system size to 4.

1. Set the trip point 3 flow rate with \swarrow , \searrow and \leftarrow .
 ⇒ Can be adjusted from trip point 2+1 to 3999 l/min.
2. Press \otimes to validate the selection and advance to the next parameter.
3. Set the trip point 3 delay with \swarrow , \searrow and \leftarrow .
 ⇒ Can be adjusted from 30 to 99 seconds.
4. Press \otimes to validate the selection and advance to the next parameter.

```
TRIP POINT 3:
      0000Lpm
```

```
TRIP DELAY 3
      30 SECONDS
```

6.1.5.16 Regeneration days override

Set the maximum number of days that the valve is in service without regenerating, regardless from the volume of water used.

Mandatory



For a timeclock valve, this value must be set as regeneration period in days !

Info



For metered valves, it is regenerated once the amount of days is reached at a preset time unless the meter triggers regeneration before.

Calendar override initiate regeneration only if no regeneration has been initiated within the delay programmed in calendar override parameter.

1. Adjust the number of days with , and .
2. Press to validate the selection and advance to the next parameter.
 - ⇒ Can be adjusted from:
 - 1 to 99 days for timeclock regeneration;
 - OFF to 99 days for metered regeneration.

Without calendar forcing.

```
REGENERATION DAY
OVERRIDE:OFF
```

Forcing every 3 days.

```
REGENERATION DAY
OVERRIDE:03DAYS
```

6.1.5.17 Regeneration start time

Set the time for regeneration start.

Mandatory



Must be set when the valve is in timeclock mode or with a calendar override !

1. Adjust the time of regeneration with , and .
2. Press to validate the selection and advance to the next parameter.

Regeneration at 2:00 am.

```
REGENERATION
TIME 02:00HR
```

6.1.5.18 Programming regeneration cycle times

Set the cycle times of the regeneration.

Info



Five cycles can be set.

The system displays the programming cycles and allows setting of a specific time for each cycle. If a cycle is set to NO, the next cycles is not activated.

The sequence of the regeneration cycles depends upon regenerant flow, see System regeneration cycle [▶ Page 21](#).

1. Adjust the cycle time with \swarrow , \searrow and \leftarrow .
2. Press  to validate the selection and advance to the next parameter.
3. Repeat for each cycle.

1. Backwash: 10 min.

```
CYCLE 1 00:10:00
          BACKWASH
```

2. Draw/Slow rinse:
1 h 10 min.

```
CYCLE 2 01:10:00
          BRINE&SLOW RINSE
```

3. Fast rinse: 10 min.

```
CYCLE 3 00:10:00
          RAPID RINSE
```

4. Refill: 10 min.

```
CYCLE 4 00:10:00
          BRINE TANK FILL
```

5. Pause: not used.

```
CYCLE 5 NO
          PAUSE & DELAY
```

6.1.5.19 Auxiliary relay/Chemical pump

Mandatory



The system can be set only with auxiliary relay or chemical pump !

Auxiliary relay

Set the relay output during regeneration.

Info



This parameter has two steps of settings.

The first one activates the output, and the second one deactivates the output.

The time 00:00:00 correspond to the beginning of regeneration time.

1. Activate the relay with and .
2. Default setting: disabled.
3. Press to validate the selection and advance to the next parameter.
4. Set the relay activation time with , and .
5. Press to validate the selection and advance to the next parameter.
6. Set the relay deactivation time with , and .
7. Press to validate the selection and advance to the next parameter.

Disabled.

```
AUXILIARY RELAY:
                DISABLED
```

Relay enabled at the beginning of regeneration.

```
AUX RELAY OUTPUT
START: 00:00:00
```

Relay disabled 10 min. after the start of regeneration.

```
AUX RELAY OUTPUT
END:    00:10:00
```

Relay enabled during cycle 2 as in chapter Programming regeneration cycles time [▶ Page 107] .

```
AUX RELAY OUTPUT
START: 00:10:00
```

```
AUX RELAY OUTPUT
END:    01:20:00
```

Chemical pump

Activate the relay output during the service based upon the volume of treated water.

Info



Only visible in metered systems.











Info



This parameter has two steps.

The first one determines the volume which activates the relay.

The second one determines how long the relay has to be activated once the volume has passed.

1. Activate the relay with  and .
2. Default setting: disabled.
3. Press  to validate the selection and advance to the next parameter.
4. Set the relay activating time with ,  and .
5. Press  to validate the selection and advance to the next parameter.
6. Set the relay deactivating time with ,  and .
7. Press  to validate the selection and advance to the next parameter.

Disabled.

```

CHEMICAL PUMP:
                DISABLED
    
```

Relay enabled every 20 litre.

```

CPO AUX RELAY
VOLUME:  0020 L
    
```

Relay enabled for 1 min.

```



CPO AUX RELAY
TIME :  00:01:00
    
```

6.1.5.20 Flow meter selection

Select the size of the flow meter.

Options:

- 1.0" paddle (standard for 2750 valve series);
- 1.0" turbine;
- 1.5" paddle (standard for 2815 and 2850 valve series);
- 1.5" turbine;
- 2.0" paddle (standard for 2900 and 3150 valve series);
- 3.0" paddle (standard for 3900 valve series);
- generic meter.

1. Select the flow meter with  and .
2. Press  to validate the selection and advance to the next parameter.

```

FLOW METER
        3.0"PADDLE
    
```

Generic meter

Info



Only visible if "generic" was selected in flow meter selection.

Set the generic meter.

Info



This parameter has two settings.

The first display is to enter the maximum flow rate of the water meter.

The second display is to enter the values for the flow meter (pulses and volume).

1. Set the maximum flow rate with \swarrow , \searrow and \leftarrow .
2. Press to validate the selection and advance to the next parameter.
3. Set the number of litres per pulse(s) with \swarrow , \searrow and \leftarrow .
4. Press to validate the selection and advance to the next parameter.
5. Set the number of pulses for the programmed number of litres with \swarrow , \searrow and \leftarrow .
6. Press to validate the selection and advance to the next parameter.

Example: 290 L/min.

```
PEAK FLOW
      0290 lpm
```

Example: 1 litre for 1 pulse.

```
ADD 001 LITER
EVERY 001 PULSES
```

Example: 5 litres for 1 pulse.

```
ADD 005 LITERS
EVERY 001 PULSES
```

Example: 2 litres for 10 pulses.

```
ADD 002 LITERS
EVERY 010 PULSES
```

6.1.5.21 Parameters saving

Info



When the last parameter is set and the button pressed, the controller updates the database based on the new programming.

Wait until programming is finished, this may take a few seconds.

```
PROGRAMMING UNIT
PLEASE WAIT...
```

6.1.6 Diagnostic

6.1.6.1 Commands

Info



Depending on current settings, some displays cannot be viewed and there is no time limit on the displays in the Diagnostic mode.

1. Press **D** to enter the Diagnostic mode.
2. Press to pass at the next step.
3. Press **D** to exit the Diagnostic mode at any time.

6.1.6.2 Current flow rate

Info



The display is updated every second.

CURRENT FLOW RAT
L/min 0Lpm

6.1.6.3 Peak flow rate

Info



The controller registers the highest flow rate since the last regeneration.



PEAK FLOW RATE
0Lpm

6.1.6.4 Totalizer

Info



The controller registers the total volume of treated water that passes through the meter since start-up (or last hard reset).

- To reset, press and hold the buttons  and  for 5 seconds until the display shows zero.

TOTALIZER :
0 L

6.1.6.5 Hours between last two regenerations

Info



Shows the number of hours between the last two regenerations, which indicates the duration of the last service cycle.

2 LAST REGEN
0 HOUR

6.1.6.6 Hours since last regeneration

Info



Shows the number of hours since the last regeneration, indicating the duration of the current service cycle.

LAST REGEN.
0 HOUR

6.1.6.7 Volume remaining

Info



Shows the volume remaining for the valve where controller is installed, excepted for system 6 where it shows the volume remaining of the complete system.

In system 4, 5, 7, 9 and 14.

```
VOL REMAINING
                100000L
```

In system 6 (complete system).

```
VOL REMAIN SYST
                0100000L
```

6.1.6.8 Valve position

Info



Shows the position of the valve in a multiple valve system, also called the valve address.

```
VALVE POSITION:
                #2
```

6.1.6.9 Software version

Info



Shows the version of the software used by the controllers.

Mandatory



In case of use of multiple valves system, verify the controller's software compatibility !

```
3200NXT:
VERSION 2.04
```

6.1.7 Resetting the controller

Mandatory



Once you have completed this operation, check all programming steps !



Info

There are two options to reset: partial and hard reset.

Partial reset will set all the parameters to default values, except flow meter totalizer volume in diagnostic mode.

Hard reset will set all the parameters to default values.

6.1.7.1 Partial reset

1. Press and hold  and  for 25 seconds until the display shows time of day.

6.1.7.2 Hard reset

1. Disconnect the power supply from the valve, press and hold the button  while reconnecting the power supply.

6.2 NXT2 Controller



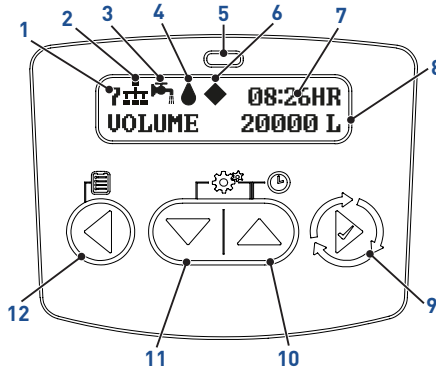

6.2.1 Display













1. System type

- 4: Single valve;
- 5: Multiple valves, parallel interlock system, 2 to 8 valves;
- 6: Multiple valves, parallel series regeneration system, 2 to 8 valves;
- 7: Duplex alternating immediate system, 2 valves;
- 8: Duplex alternating delayed system, 2 valves;
- 9: Multiple valves, parallel system with standby unit, 2 to 8 valves;
- 14: Multiple valves, system on-demand, 2 to 8 valves.

2. Network Indicator

-  Connected;
-  Disconnected;
-  Unit missing;
-  USB Connected.

- | | |
|--------------------------|---|
| 3. Valve status | <ul style="list-style-type: none"> •  Initializing: after a power failure or a change in the programming, the controllers initializes for approximately 30 seconds; •  Lock windows: the controller has acquired the lockout windows; •  Lock remote: the controller has acquired the lockout remote; •  Regeneration Inhibition indicator: In a multi-valves system, a valves is in regeneration while another valve is waiting for regeneration; •  Valve in service; •  Flashing: Regeneration queued; •  Valve in standby; •  Remote Regeneration. |
| 4. Flow indicator | <ul style="list-style-type: none"> •  Flashing when flow is going through the meter. |
| 5. LED Status Indicator | <ul style="list-style-type: none"> • Blue: In Service • Flashing blue: Regeneration Queued • Green: Regeneration • Flashing green: Standby • Red: Error condition present • All LED flashing: Delayed unlock |
| 6. Master unit indicator | <ul style="list-style-type: none"> •  Master unit (auto-assigned) for multi-unit system; • Empty for single unit. |
| 7. Time of the day | <ul style="list-style-type: none"> • 24h mode or 12h am/pm depending on units type selected |
| 8. Operating mode | <ul style="list-style-type: none"> • Remaining volume in volumetric mode; • Remaining days before regeneration in timeclock mode. |
| 9. Regen. button | <ul style="list-style-type: none"> • Navigate to next menu option • Display time of programmed regeneration |
| 10. Up button | <ul style="list-style-type: none"> • Adjust menu value up |
| 11. Down button | <ul style="list-style-type: none"> • Adjust menu value down |
| 12. Left button | <ul style="list-style-type: none"> • Navigate to previous menu option |

6.2.2 Commands

6.2.2.1 Menu commands

Info



At any time, press to return to previous screen without saving.

Menus are displayed in a defined and incremental order.

Editable digit is marked by two triangles (Cursor).

If none of the buttons are pushed for 5 minutes in the Programming mode, or if there is a power failure, the controller returns to Service mode without saving.

Mandatory



In order to store the new settings in the programming mode, it is necessary to go through all the parameters !

1. Press to pass to the next step and save programming.
2. Use to move the cursor to the next digit, or use to move the cursor to the previous digit.
3. Use and to adjust the values.
4. Press at any time to return to previous step without saving the current parameters changes.

6.2.2.2 Access commands

1. Hold pressed 2 seconds the following buttons.

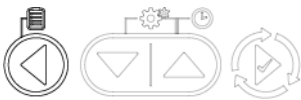

- Enter diagnostic menu

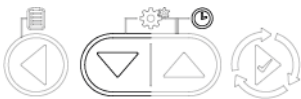

- Enter time of day menu

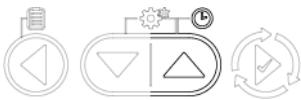

- Enter time of day menu

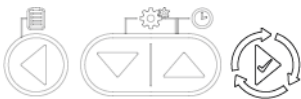

- Initiate an immediate regeneration

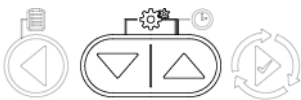

- Access to user programming menu



- Access to master programming menu

6.2.3 Time of day menu

Mandatory



In multiple valve systems, set the time of day on the lead valve (#1) !

The time of day will be automatically updated on the other valves in the system within 10 seconds.

6.2.3.1 Time of day

Set the time in the system.

1. Press ▼ or ▲ for 2 seconds.
2. Adjust as desired the time with ▼, ▲ and ▶.
3. Press ▶ to validate the selection and advance to the next parameter.

TIME

12:34HR

6.2.3.2 Year

Set the year.

1. Set the year with ▼ and ▲:
2. Press ▶ to validate the selection and advance to the next parameter.

YEAR

2019

6.2.3.3 Month

Set the month.

1. Set the month with ▼ and ▲:
2. Press ▶ to validate the selection and advance to the next parameter.

MONTH

SEP

6.2.3.4 Calendar day

Set the day of the month.

1. Set the day of the month with ▼ and ▲:
2. Press ▶ to validate the selection and advance to the next parameter.

CALENDAR DAY

1

6.2.4 Basic programming

6.2.4.1 Basic programming mode chart

Parameter	Options	Definition	Note
DAY OVERRIDE / TIME DRIVEN	OFF to 99	Day	Days between regenerations only for metered regeneration types.
	4, 8, 12, 16, 20	Hour	Hours or days between regenerations only for time clock regeneration type.
	1 to 1999	Day	
REGENERATION TIME	00:00 to 23:59	Hour	Regeneration time will not appear when day override/time driver is by hours for time clock or OFF for meter immediate regeneration type.
HARDNESS	1 to 1999	Gram as CaCO ₃ equivalent if hardness unit is mg/L °FTH if hardness unit is °FTH °dH if hardness unit is °dH °eH if hardness unit is °eH	Those screens will only display when regeneration type selected is softener meter immediate or delayed.
VOLUME REMAINING	0 to 4820	Litre	
PUSH SETTINGS	ON	(default)	Only displayed for multi unit systems.
	OFF	-	

6.2.4.2 Day Override / Time-driven

Set the maximum number of days between two regenerations, regardless from the volume of water treated.

Mandatory



Must be set for timeclock valve !

Consequences

Info



For metered valves, calendar override parameter would trigger a regeneration, only if the volumetric control did not start a regeneration before calendar override period elapsed.

Each volumetric regeneration happening reset the calendar override delay.

Calendar override is not visible in «Day of the week» mode.

1. Press and hold ▼ and ▲ simultaneously to enter user programming mode.
2. Select the number of days or hours with ▼ and ▲.
3. Press ▶ to validate the selection and advance to the next parameter.
 - ⇒ Can be adjusted with 4H, 8H, 12H, 16H, 20H or from 1 to 99 days for timeclock regeneration and from OFF to 99 days for metered regeneration.

Without calendar override.

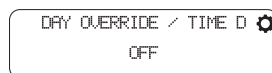

Override every 3 days.

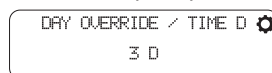

6.2.4.3 Regeneration time

Set the time for regeneration start.

Mandatory



Must be set when the regeneration flow programmed is timeclock, day of week mode, volumetric delayed mode and any time a calendar override period is set !

1. Adjust the time with ▼ and ▲.
2. Press ▶ to validate the selection and advance to the next parameter.

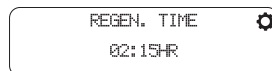

6.2.4.4 Hardness

Set the inlet water hardness in the unit defined on chapter Units [▶ Page 100].

Info



This parameter is not visible in "Filter " mode.

1. Adjust the hardness with ▼, ▲ and ▶.
2. Press ▶ to validate the selection and advance to the next parameter.



6.2.4.5 Volume remaining

Display the remaining volume before the system's capacity is exhausted. This parameter can be adjust if necessary, and will be reset to the programmed capacity after next regeneration.

Info



This parameter is visible only in "Softener meter immediate/delayed " mode

1. Adjust the volume with ▼, ▲ and ▶.
2. Press ▶ to validate the selection and advance to the next parameter.



6.2.4.6 Push settings

This parameter allows to push and copy settings from the master unit to all other connected units.

Info



This parameter is visible only in multi-units systems.

1. Select OFF or ON with ▼ and ▲.
2. Press to validate the selection.

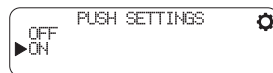

6.2.5 Master programming mode

Info



As soon as programming mode is entered, all parameters can be displayed or set to suit the needs.

Depending on the current programming, some functions will not be displayed or will not be changeable.

6.2.5.1 Master programming mode chart

Parameter	Options	Definition	Note
SETTINGS REVIEW	ON	-	When settings review mode is on, no programming changes can be done.
	OFF (Default)	-	
LANGUAGE	ENGLISH	English (default)	-
	FRANCAIS	French	
	DEUTSCH	German	
	ITALIANO	Italian	
	ESPANOL	Spanish	
	NEDERLANDS	Dutch	
	PORTUGUES	Portuguese	
ASSISTANCE NAME 1	-	-	12 characters maximum.
ASSISTANCE NAME 2	-	-	
ASSISTANCE PHONE	-	-	14 characters maximum.

Parameter	Options	Definition	Note
SYSTEM TYPE	4	Single unit (default)	1 unit.
	5	Parallel interlock	2 to 8 units.
	6	Parallel series regeneration	
	7	Alternating immediate	2 units.
	8	Alternating delayed	
	9	Parallel with standby unit	2 to 8 units.
	14	On-demand	
NUMBER OF TANKS	2 to 8	Valves in the system	This screen will not be displayed for system type 4, 7 and 8.
TRIP POINT #X - LPM	1 to 7563	l/min	System 14 only.
TRIP POINT #X - SERVICE DURATION	1 to 90	Second	System 14 only; Duration for which the service flow rate must be greater than the above trip point flow rate to cause the next tank to move into service position.
TRIP POINT #X - STANDBY DURATION	60 to 300	Second	System 14 only; Duration for which the service flow rate must become lower than the above trip point flow rate to cause one of the tank of the system to move back into stand-by position.
VALVE	2510	-	Valve type.
	2750	(default)	
	2850	-	
	2900	-	
	3150	-	
	3900	-	
	2815	-	
REGEN. FLOW	DOWN FLOW	Down flow softener (default)	-
	UP FLOW	Up flow softener	
	FILTER	Filter	

Parameter	Options	Definition	Note
REGEN. TYPE	TIME CLOCK	Time clock (default)	System 4 and 6 only.
	DAY OF THE WEEK	Regeneration on selected days	System 4 and 6 only.
	METER IMMEDIATE	Metered immediate	All system unless system 8.
	METER DELAYED	Metered delayed	Systems 4, 6 and 8 only.
UNITS	US	US units (default)	-
	METRIC	Metric units	
VOL. OVERRIDE/ VOLUMETRIC	0 to 9999999	Litre	This screen will only display when regeneration type selected is filter meter immediate or Delayed.
HARDNESS UNITS	mg/L	mg/L as CaCO ₃ equivalent (default)	This screen will only display when regeneration type selected is softener meter immediate or delayed with metric units.
	*DH	-	
	*FTH	-	
	*EH	-	
CAPACITY	0 to 9999999	Gram as CaCO ₃ equivalent if hardness unit is mg/L L x °FTH if hardness unit is °FTH L x °dH if hardness unit is °dH L x °eH if hardness unit is °eH	Those screens will only display when regeneration type selected is softener meter immediate or delayed.
HARDNESS	1 to 1999	Gram as CaCO ₃ equivalent if hardness unit is mg/L °FTH if hardness unit is °FTH °dH if hardness unit is °dH °eH if hardness unit is °eH	Those screens will only display when regeneration type selected is softener meter immediate or delayed.
RESERVE	WEEKLY RESERVE	(default)	This screen will only display when regeneration type selected is softener meter delayed.
	VARIABLE RESERVE	-	
	FIXED%	-	
	FIXED VOLUME	-	

Parameter	Options	Definition	Note
FIXED%	0 to 50	%	This screen will only display when regeneration type selected is softener meter delayed with fixed% reserve; Any value set above 50% will be discard and 50% will be considered as % reserve.
FIXED VOLUME	0 up to the half of the total capacity	Litre	This screen will only display when regeneration type selected is softener meter delayed with fixed volume reserve; Range depend on capacity value. Any value set above the half of the capacity will be discarded and considered as the half of the capacity.
REMOTE REGENERATION	OFF	(default)	-
	IMMEDIATE	-	
	DELAYED	-	
REMOTE SIGNAL DURATION	1 to 5940	Second	Only displayed if immediate or delayed is chosen for remote regeneration.
DAY OF WEEK	SU	Sunday (default)	This screen will only display when regeneration type selected is day of week; Activate or de-activate for each position (X = deactivated; ✓ = activated).
	MO	Monday	
	TU	Tuesday	
	WE	Wednesday	
	TH	Thursday	
	FR	Friday	
	SA	Saturday	
DAY OVERRIDE / TIME DRIVEN	OFF to 99	Day	Days between regenerations only for metered regeneration types.
	4, 8, 12, 16, 20	Hours	Hours or days between regenerations only for time clock regeneration type.
	1 to 99	Day	
REGENERATION TIME	00:00 to 23:59	Hour	Regeneration time will not appear when day override/time driver is by hours for time clock or OFF for meter immediate regeneration type.
LOCK WINDOW #1	ON	-	Period during which no regeneration can start. Maximum 2 lock windows programmable.
	OFF	(default)	

Parameter	Options	Definition	Note
LOCK START #1	00:00 to 23:59	Hour	This screen will only display when lock windows #1 is on.
LOCK END #1	00:00 to 23:59	Hour	This screen will only display when lock windows #1 is on.
LOCK WINDOW #2	ON	-	This screen will only display when lock windows #1 is on.
	OFF	(default)	
LOCK START #2	00:00 to 23:59	Hour	This screen will only display when lock windows #1 and 2 are ON.
LOCK END #2	00:00 to 23:59	Hour	This screen will only display when lock windows #1 and 2 are ON.
BACKWASH	0 to 240	Minute	-
DRAW	0 to 240	Minute	Brine draw and slow rinse. This screen will not be displayed for filter systems.
RAPID RINSE	0 to 240	Minute	-
TANK REFILL	0 to 240	Minute	Regenerant tank refill. This screen will not be displayed for filter systems.
PAUSE	0 to 240	Minute	This screen will not be displayed for filter systems.
METER TYPE	GENERIC	-	Default flow meter type is based on the valve type; This screen will only display on the lead (#1) unit for system types 6, 7 & 8.
	0.75" PADDLE	(default for 2510)	
	0.75" TURBINE	-	All other system types it will display for all units;
	1.0" PADDLE	(default for 2750)	
	1.0" TURBINE	-	
	1.25" TURBINE	-	This screen will only display when regeneration type selected is softener meter immediate or delayed.
	1.5" PADDLE	(default for 2815 and 2850)	
	1.5" TURBINE	-	
	2.0" PADDLE	(default for 2910 and 3150)	
3.0" PADDLE	(default for 3900)		
PULSES/L	0 to 1500	PULSES/L	Only displayed if "Generic" is chosen for the meter type.
MAXIMUM FLOW - LPM	76 to 7570	l/min	

Parameter	Options	Definition	Note
CONTINUOUS FLOW DETECT	ON	-	This screen will only display when regeneration type selected is softener meter immediate or delayed.
	OFF	(default)	
CONTINUOUS FLOW DETECT - FLOW RATE- LPM	0.1 to 227.1	l/min	Only displayed if continuous flow detect is ON. Even if maximum theoretical programmable value is 999.9 l/min, the controller will consider only up to 227.1 l/min.
CONTINUOUS FLOW DETECT - DURATION	1 to 255	Hour	Only displayed if continuous flow detect is ON.
AUXILIARY 1	STANDBY		Activates relay from beginning of regeneration and during standby phase.
	OFF	(default)	-
	ALARM BASED	-	Any alarm or error detected by the controller will start signal output from Auxiliary relay#1.
	CYCLE BASED	-	-
	TIME BASED	-	-
	VOLUME BASED	-	This choice will only available when metered regeneration type.
AUX. 1: CYCLE BASED	SP	Service position	Only displayed if "Cycle based" is chosen for auxiliary 1; Activate or de-activate for each position (✗ = deactivated; ✓ = activated).
	BW	Backwash position	
	BD	Draw and slow rinse position	
	RR	Rapid rinse position	
	RF	Refill position	
	SB	Pause position	
AUX. 1: TIME BASED - START TIME #1	0 to total regeneration time minus 1 minute	Minute	Only displayed if "Time based" is chosen for auxiliary 1.
AUX. 1: TIME BASED - END TIME #1	from start time#1 plus 1 minute until total regeneration duration	Minute	

Parameter	Options	Definition	Note
AUX. 1: TIME BASED - START TIME #2	OFF End time #1 to total regeneration duration minus 1 minute	Minute	Only displayed if "Time based" is chosen for auxiliary 1 and END TIME #1 < total regeneration duration minus 1 minute; Range depend on Start and end time #1 values.
AUX. 1: TIME BASED - END TIME #2	OFF From start time #2 + 1 minute until the total regeneration duration	Minute	Only displayed if "Time based" is chosen for auxiliary 1 and START TIME #2 ON; Range depends on Start and end time #1 values.
AUX. 1: VOLUME BASED - VOLUME - L	0 to MAX	Litre	Only displayed if "volume based" is chosen for auxiliary 1; Volume range depend on capacity; Even if maximum theoretical programmable value is 999999 the controller will take the unit capacity as maximum volume.
AUX. 1: VOLUME BASED - DURATION	1 to 7200	Second	Only displayed if "volume based" is chosen for auxiliary 1; Volume range depend on capacity; Even if maximum theoretical programmable value is 9999 the controller will take 7200 as duration.
AUXILIARY 2	STANDBY		Activates relay from beginning of regeneration and during standby phase.
	OFF	{default}	-
	ALARM BASED	-	Any alarm or error detected by the controller will start signal output from Auxiliary relay#2.
	CYCLE BASED	-	-
	TIME BASED	-	-
	VOLUME BASED	-	This choice will only available when metered regeneration type.

Parameter	Options	Definition	Note
AUX. 2: CYCLE BASED	SP	Service position	Only displayed if "Cycle based" is chosen for auxiliary 2; Activate or de-activate for each position (✗ = deactivated; ✓ = activated).
	BW	Backwash position	
	BD	Draw and slow rinse position	
	RR	Rapid rinse position	
	RF	Refill position	
	SB	Pause position	
AUX. 2: TIME BASED - START TIME #1	0 to total regeneration time minus 1 minute	Minute	Only displayed if "Time based" is chosen for auxiliary 2.
AUX. 2: TIME BASED - END TIME #1	from start time#1 plus 1 minute until total regeneration duration	Minute	
AUX. 2: TIME BASED - START TIME #2	OFF End time #1 to total regeneration duration minus 1 minute	Minute	Only displayed if "Time based" is chosen for auxiliary 2 and END TIME #1 < total regeneration duration minus 1 minute; Range depend on Start and end time #1 values.
AUX. 2: TIME BASED - END TIME #2	OFF From start time #2 + 1 minute until the total regeneration duration	Minute	Only displayed if "Time based" is chosen for auxiliary 2 and START TIME #2 ON; Range depend on Start and end time #1 values.
AUX. 2: VOLUME BASED - VOLUME - L	0 to MAX	Litre	Only displayed if "volume based" is chosen for auxiliary 1; Volume range depend on capacity; Even if maximum theoretical programmable value is 999999 the controller will take the unit capacity as maximum volume.

Parameter	Options	Definition	Note
AUX. 2: VOLUME BASED - DURATION	1 to 7200	Second	Only displayed if "volume based" is chosen for auxiliary 1; Volume range depend on capacity; Even if maximum theoretical programmable value is 9999 the controller will take 7200 as duration.
PUSH SETTINGS	ON	(default)	Only displayed for multi unit systems.
	OFF	-	
SAVE AS NON-FACTORY	ON	-	The non-factory configuration can be used on RESET.
	OFF	(default)	-
LOCK OPTIONS	OFF	(default)	Lock setting prevents unexpected access to master programming.
	DELAYED	-	
	ENTER CODE	-	
	TIME BASED	-	

6.2.5.2 Entering master programming mode

1. Press and hold and simultaneously for two seconds to enter the master programming mode;
2. Set the password using , and ;
 - ⇒ If the controller calls for a Password that is unknown to you, please contact your installer.

If lock settings is activated.



6.2.5.3 Settings review

Activate or deactivate the settings review mode.

Options:

- on: all parameters and current programming can be displayed but not modified;
 - off: all parameters are displayed and programmable.
1. Adjust the time with and .
 2. Press to validate the selection and advance to the next parameter.

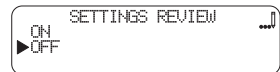

6.2.5.4 Language setting

Select the displayed language.

Options:

- English;
- French;
- German;

- Italian;
 - Spanish;
 - Dutch;
 - Portuguese.
1. Select the system type with ▼ and ▲;
 2. Press ▶ to validate the selection and advance to the next parameter.



6.2.5.5 Assistance name 1 and 2

Edit names of assistance.

Info



Maximum 12 characters per screen.

Tip



Press the ▶ button for 2 seconds to go immediately to next screen.

To correct a digit, Press the ◀ or ▶ button to move the cursor on a digit to correct.

1. Edit assistance name using ▼, ▲ and ▶;
 - ⇒ Assistance name is empty by default;
 - ⇒ Each character can be chose from A to Z or stay empty;
2. Press ▶ to validate the selection and advance to the next parameter.



6.2.5.6 Assistance phone

Edit phone number.

Info



Maximum 14 digits.

Tip



Press the ▶ button for 2 seconds to go immediately to next screen.

1. Edit assistance phone using ▼, ▲ and ▶;
 - ⇒ Assistance phone is empty by default;
 - ⇒ Each character can be chose from 1 to 9 or stay empty;
2. Press ▶ to validate the selection and advance to the next parameter.

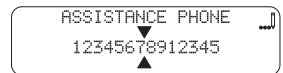

6.2.5.7 System type

Select the system in which the valve(s) operate(s).

Options:

- 4: single valve;
- 5: multiple valves, parallel interlock system (2- 8 units);
- 6: multiple valves, parallel series regeneration system (2- 8 units);
- 7: duplex alternating immediate system (2 units);
- 8: duplex alternating delayed system (2 units);
- 9: multiple valves, parallel system with standby unit (2- 8 units);
- 14: multiple valves, system on-demand (2- 8 units).

1. Select the system type with ▼ and ▲;

⇒ Default system: system 4;

2. Press ▶ to validate the selection and advance to the next parameter.

Example: 4 Single valve.

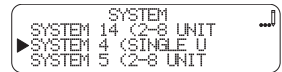

Example: 5 multiple valves.

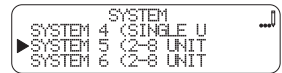

6.2.5.8 Number of tanks

Set the number of valves to be connected (2 to 8 valves) in the system.

Info



Only visible in multiple valve systems and only present on the master valve.

Options:

- 2 to 8 valves in the system.

1. Select number of tanks with ▼ and ▲;

⇒ Default setting: 2 valves;

2. Press ▶ to validate the selection and advance to the next parameter.

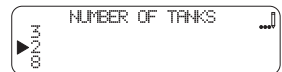

6.2.5.9 Trip points setting

Set the flow rate and switching service and standby duration.













Info



Only visible in system 14, and on master valve, identified by  on the controller screen.

Depending on the number of tank used in the system, there might up to 7 trip point to set up (for 8 tanks systems).

Each additional trip point might be set for a flow rate equal to the previous one plus 1 l/min.

1. Set the trip point flow rate with ,  and ;
 - ⇒ Can be adjusted from 1 to 7569 l/min;
2. Press  to validate the selection and advance to the next parameter;
3. Set the trip point service duration with ,  and ;
 - ⇒ Can be adjusted from 1 to 90 seconds;
4. Press  to validate the selection and advance to the next parameter;
5. Set the trip point service standby with ,  and ;
 - ⇒ Can be adjusted from 60 to 300 seconds;
6. Press  to validate the selection and advance to the next parameter.

Example: trip point #1.

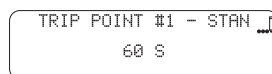
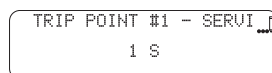
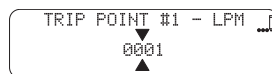



6.2.5.10 Valve type

Select which valve is being used with the NXT2.

Options:

- 2510
- 2750;
- 2850;
- 2900/2910;
- 3150;
- 3900;
- 2815.

1. Set valve type at 3900 with  and .
2. Default setting: 2750;
3. Press  to validate the selection and advance to the next parameter.

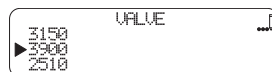

6.2.5.11 Regeneration flow

Set the direction of flow during the brine draw cycle for softener, or set filter.

Options:

- down flow;
- up flow (do not use for 2510 and 2850 valve types);
- filter.

1. Set regeneration flow with ▼ and ▲;

⇒ Default setting: down flow;

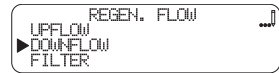

2. Press ► to validate the selection and advance to the next parameter.

6.2.5.12 Regeneration type

Select the regeneration type.

Info



The availability depends on regeneration flow (softener or filter) type programmed in the previous step.

This screen will only display for system 4 and 6.

For all other systems the regeneration type is defined by default: meter delayed for system 8 and meter immediate for system 5, 7, 9 and 14.

Options:

- time clock: The unit will regenerate at the preset regeneration time once the preset interval between two regeneration elapsed;
- day of the week: The unit will regenerate on preset day(s) of the week at the preset regeneration time;
- softener or filter meter delayed: When volume remaining reaches zero and the scheduled regeneration time is reached (default 2 a.m. softener; 12 a.m. filter), the unit will regenerate;
- softener or filter meter immediate: When volume remaining reaches zero, the unit will regenerate.

1. Set regeneration type with ▼ and ▲;

⇒ Default regen. type: time clock;



2. Press ► to validate the selection and advance to the next parameter.

6.2.5.13 Units

Set the unit system to be used.

Options:

- US: volume in gallons, time display 2 x 12 hours, hardness in grains;
- metric: volume in litre, time display 24 hours and hardness depends on hardness unit set (see Hardness units [►Page 101])

1. Set the unit system with ▼ and ▲;

⇒ Default system unit: US;

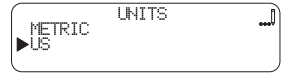

2. Press ▶ to validate the selection and advance to the next parameter.

6.2.5.14 Volume override/ Volumetric

Set the volume of water between 2 cleaning/regeneration cycles.

Info



Available only for filter metered systems.

1. Set the volume override with ▼, ▲ and ▶;

⇒ Can be adjusted from 0 to 9'999'999 litres;



2. Press ▶ to validate the selection and advance to the next parameter.

6.2.5.15 Hardness units

Set hardness unit system to be used.

Info



This screen is displayed only if units mode programmed is metric (Units [▶ Page 100]).

1°F = 10 mg/L CaCO₃ = 10ppm CaCO₃ = 0.56°dH = 0.7 °eH

Options:

- mg/L;
- °DH: German;
- °FTH: French;
- °EH: English.

1. Set hardness unit with ▼ and ▲;

⇒ Default metric hardness unit: mg/L;

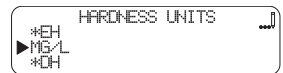

2. Press ▶ to validate the selection and advance to the next parameter.

6.2.5.16 Capacity

Set the capacity of the tank where the valve is installed.

Info

Available only for softening metered systems.

Based upon the system capacity, safety coefficient and inlet water hardness, the controller calculates the volume of water that the system can treat between 2 regenerations.

When hardness unit is programmed in mg/L as CaCO₃, the capacity must be programmed in grams as CaCO₃ equivalent and correspond to the total equivalent mass of CaCO₃ that the system can treat before requiring regeneration.

When the hardness unit is programmed in °FTH, °dH or °EH, the capacity must be programmed in litre and correspond to the total volume of water the system could treat if the inlet water hardness was 1° in the corresponding unit before requiring regeneration.

1. Set the capacity with ▼, ▲ and ▶;
2. Can be adjusted from 0 to 9.999.999 grams;
3. Press ▶ to validate the selection and advance to the next parameter.

Example: 3000 g of CaCO₃ of capacity.

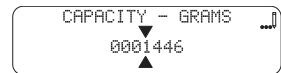

6.2.5.17 Hardness

Set the inlet water hardness in the unit set on chapter Hardness units [▶ Page 101]

1. Set hardness with ▼ and ▲;
 - ⇒ Can be adjusted from:
 - ⇒ 1 – 1999 mg/l;
 - ⇒ 1- 199 °F;
 - ⇒ 1 - 112.0 °dH;
 - ⇒ 1 - 140.2 °eH.
 - ⇒ Any value programmed above the maximum value for each unit will be discarded and considered as the maximum above mentioned value for the relevant unit.
2. Press ▶ to validate the selection and advance to the next parameter.

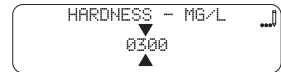

6.2.5.18 Reserve

Set the reserve type.

Info

Available only for softening metered systems.

Options:

- weekly reserve;
- variable reserve;

- fixed%;
 - fixed volume.
1. Select reserve type with ▼ and ▲;
 2. Press ▶ to validate the selection and advance to the next parameter.



Fixed%

Set the percentage of the total unit capacity used to calculate the unit safety reserve capacity.

Info



The availability depends on reserve type programmed in the previous step.

1. Set the safety coefficient with ▼, ▲ and ▶;
 - ⇒ Can be adjusted from 0 to 50%;
 - ⇒ Any value programmed above the maximum value will be discarded and considered as the maximum above mentioned value.
2. Press ▶ to validate the selection and advance to the next parameter.

No safety factor programmed.

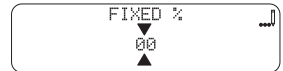

Fixed volume

Set a fixed volume as safety reserve capacity.

Info



The availability depends on reserve type programmed in the previous step.

1. Set the reserve volume with ▼, ▲ and ▶;
 - ⇒ The volume range depend on capacity, in litre if metric units were programmed or US gallon if US units were programmed (see Units [▶Page 100]);
 - ⇒ The maximum reserve volume capacity settable will correspond to the half of the total volume.
2. Press ▶ to validate the selection and advance to the next parameter.



6.2.5.19 Remote regeneration

Set the regeneration type for remotely started regeneration (external dry contact input, see chapter NXT2 controller connections [▶Page 55]).

Info



This mode can be combined with the other methods of regeneration

The remotely started regenerations overrule the other regeneration type once the signal is acquired.

Options:

- off;
 - immediate;
 - delayed.
1. Set the remote regeneration mode with ▼ and ▲;

⇒ Default setting: off;

2. Press ► to validate the selection and advance to the next parameter.

Remote regeneration deactivated.

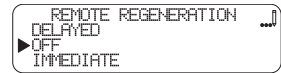

6.2.5.20 Remote signal duration

Set remote signal duration.

Info



The availability depends on remote regeneration option programmed in the previous step.

The contact will close after a preset signal duration. When the contact closes, remote regeneration signal is acquired and a regeneration will start (immediate or delayed) as programmed in Remote regeneration [► Page 103].

1. Set the signal duration with ▼ and ▲;
- ⇒ Can be adjusted from 1 to 5940 seconds;

2. Press ► to validate the selection and advance to the next parameter.



6.2.5.21 Day of the week

Select the day of the week of regeneration.

Info



Available only for day of the week regeneration type.

Options:

- Sunday;
- Monday;
- Tuesday;
- Wednesday;
- Thursday;

- Friday;
 - Saturday.
1. Select the days for regeneration with ▼ and ▲;
 - ⇒ Default setting: Sunday;
 - ⇒ Multi-selection is possible;
 - ⇒ Not selected days are marked by ✗ and selected days are marked by ✓;
 2. Press ▶ to validate the selection and advance to the next parameter.

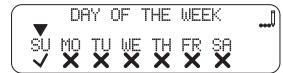

6.2.5.22 Day override/time driven

Set the maximum number of days between two regenerations regardless from any other regeneration triggering type that could be programmed.

Mandatory



**For a timeclock valve, must be set as regeneration period in hours or days !
For metered valves, must be set in days !**

Info



Not available if the regeneration type programmed is Day of week mode.

1. Adjust the number of days with ▼ and ▲;
 - ⇒ Can be adjusted with 4H, 8H, 12H, 16H, 20H or from 1 to 99 days for timeclock regeneration and from OFF to 99 days for metered regeneration;
2. Press ▶ to validate the selection and advance to the next parameter.

Calendar override deactivated.

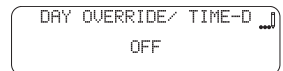

Override every 3 days.

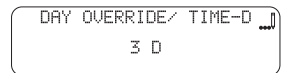

6.2.5.23 Regeneration time

Set the time for regeneration start.

Info



Depending on regeneration flow programmed, this parameter may be displayed or not.

1. Adjust the time of regeneration with ▼, ▲ and ▶;
2. Can be adjusted from: 00:00 to 23:59HR;
3. Press ▶ to validate the selection and advance to the next parameter.

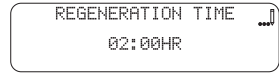

6.2.5.24 Lock setting

Set Lock Window settings: Enable lock windows then select the desired Lock Start time and Lock End time.

Info



Lock Window prevents the unit from regenerating during a specified time frame.
Two lock windows are available (Lock Window #1 and Lock Window #2).

Mandatory



Before deactivating lock window #1, you must deactivate lock window #2 first, otherwise lock window #2 will remain active but not visible anymore in the programming.

Lock window #1

Set Lock Window #1 settings.

1. Enable lock window with ▼ and ▲;
⇒ Default setting: off;
2. Press ▶ to validate the selection and advance to the next parameter.
3. Set lock start time with ▼ and ▲;
4. Press ▶ to validate the selection and advance to the next parameter.
5. Set lock end time with ▼ and ▲;
6. Press ▶ to validate the selection and advance to the next parameter.

Lock window #1 activated.

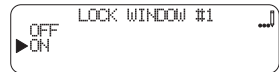

Lock window #1 starts at 12:00.

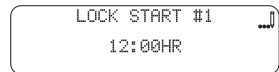

Lock window #1 ends at 13:00.

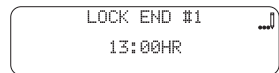

Lock window #2

Set Lock Window #2 settings.

Info



Lock Window #2 settings are accessible only if lock windows #1 is on.

1. Enable lock window with ▼ and ▲;
⇒ Default setting: off;
2. Press ▶ to validate the selection and advance to the next parameter.
3. Set lock start time with ▼ and ▲;
4. Press ▶ to validate the selection and advance to the next parameter;
5. Set lock end time with ▼ and ▲;
6. Press ▶ to validate the selection and advance to the next parameter.

Lock window #2 activated.

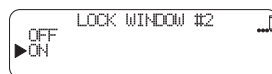

Lock window #2 starts at 13:00.

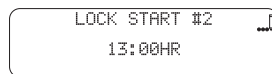

Lock window #2 ends at 14:00.

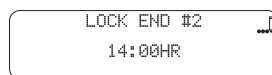

6.2.5.25 Programming regeneration cycles time

Set the regeneration cycles duration in minutes.

Info



A maximum of 5 cycles can be programmed.

For filter system only backwash and rapid rinse are available.

The sequence of the regeneration cycles depends upon regenerant flow, see System regeneration cycle [▶ Page 21].

1. Adjust the cycle time with ▼ and ▲;
⇒ Can be adjusted from: 0 to 240 minutes;
2. Press ▶ to validate the selection and advance to the next parameter;
3. Repeat for each cycle.

1. Backwash: 10 min.

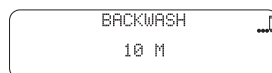

2. Draw: 60 min.

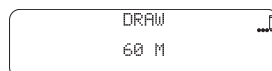

3. Rapid rinse: 10 min.

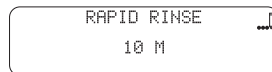

4. Tank Refill: 12 min.

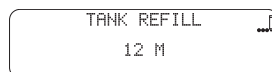

5. Pause: not used.

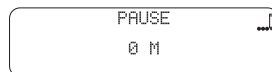

6.2.5.26 Meter type

Select the size of the flow meter.

Info



Available only for softening metered systems.

Options:

- 0.75" paddle (standard for 2510 valve series);
- 0.75" turbine;
- 1.0" paddle (standard for 2750 valve series);
- 1.0" turbine;
- 1.25" turbine;
- 1.5" paddle (standard for 2815 and 2850 valve series);
- 1.5" turbine;
- 2.0" paddle (standard for 2900 and 3150 valve series);
- 3.0" paddle (standard for 3900 valve series);
- generic.

1. Select the meter type with ▼ and ▲;

2. Press ▶ to validate the selection and advance to the next parameter.

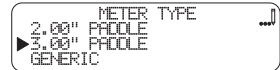

Generic meter

Set the generic meter settings.

Info



Only visible if "generic" was selected as meter type in the previous step.

This parameter has two settings.

- Enter the number of pulses per 1 unit of volume.
- Enter the maximum expected flow rate.

1. Set the number of pulses per litre with ▼, ▲ and ▶;

2. Can be adjusted from: 0 to 1500 Pulses/L;

3. Press ▶ to validate the selection and advance to the next parameter;

4. Set the maximum flow with ▼, ▲ and ▶;

5. Can be adjusted from: 67 to 7570 l/min;

6. Press ▶ to validate the selection and advance to the next parameter.

Example: 1 pulse per 1L.



Example: 2000 l/min.

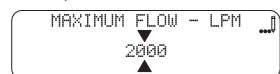

6.2.5.27 Continuous flow detect settings

Set continuous flow detect.

Info



Alert appears when specified continuous flow rate is detected during service over a specified duration.

Available only for softening metered systems.

Note that flow rate observed due to leaks are generally much smaller than service flow rate and this parameter must therefore be programmed accordingly.

This parameter has three settings:

The first one enables or disables continuous flow detection option.

If activated, then 2 step will call for flow rate until which a permanent flow could be considered as a leak.

The 3rd step will call for programming the period as of which a flow rate lower or equal to the setting in step 2 is considered as a leak and therefore causes the alarm display on the screen.

Info



Options:

- on;
- off.

1. Set continuous flow on with ▼ and ▲;
2. Default setting: off;
3. Press ▶ to validate the selection and advance to the next parameter;
4. Adjust flow rate with ▼, ▲ and ▶;
5. Can be adjusted from: 0.1 to 227.1 l/min;
6. Press ▶ to validate the selection and advance to the next parameter;
7. Adjust duration with ▼ and ▲;
8. Can be adjusted from: 1 to 255 Hours;
9. Press ▶ to validate the selection and advance to the next parameter.

Continuous flow detect activated.

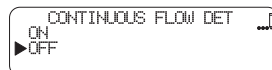

Continuous flow detect - Flow rate 0.1 l/min.

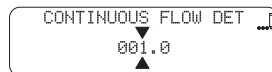

Continuous flow detect - Duration 8H.

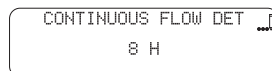

6.2.5.28 Auxiliary Relays settings

Program auxiliary output relays (dry contact). To locate the relays on the board, see AUX 1 and AUX 2 at NXT2 controller connections [▶Page 55].

Info

The NXT2 has two auxiliary relays available based on alarm, cycle, time or volume.
 The following settings are auxiliary 1 settings and are the same for auxiliary 2.

Options:

- standby (activates relay from beginning of regeneration and during standby phase);
- off;
- alarm based;
- cycle based;
- time based;
- volume based.

1. Choose the options of relay with ▼ and ▲;
2. Default setting: disabled;
3. Press ▶ to validate the selection and advance to the next parameter.

Disabled.

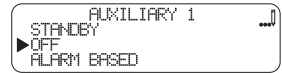

Cycle based

Set the cycle based relay output during regeneration.

Info

Only visible if "cycle based" was selected as auxiliary in the previous step.

1. Choose the options of relay with ▼ and ▲;
 - ⇒ Unselected cycle are marked by X;
 - ⇒ Activated cycles are marked with a ✓;
 - ⇒ Multi-selection is possible;
2. Press ▶ to validate the selection and advance to the next parameter.

Activated during selected cycle step.

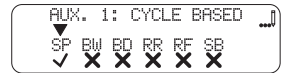

Time based

Set the time based relay output during regeneration.

Info

Only visible if "time based" was selected as auxiliary in the previous step.

This parameter has two steps of settings for each time Start time # / End time#.
 The first one activates the relay output, and the second one deactivates the relay output.
 The time 0 MIN corresponds to the beginning of regeneration time.
 If the first interval of activation does not cover the whole regeneration duration, it is possible to set up a second interval.

1. Set the relay Start time #1 with ▼ and ▲;
2. Can be adjusted from:0 to the total regeneration duration minus 1 minute;
3. Press  to validate the selection and advance to the next parameter.
4. Set the relay End time #1 with ▼ and ▲;
5. Can be adjusted from: start time #1 + 1 to the total regeneration time, in minutes;
6. Should the End time#1 be shorter than the total regeneration duration, a second interval may be programmable in the remaining period of regeneration, provide this remaining period is long enough to allow activation/deactivation of the relay (minimum 2 minutes are required).

Activated as of the regeneration starts.



TIME BASED - START
TIME #1.

AUX. 1: TIME BASED - ...
0M

Deactivated 10 minutes after the regeneration started.

TIME BASED - END
TIME #1.

AUX. 1: TIME BASED - ...
10M

7. Press  to validate the selection and advance to the next parameter;
1. Set the relay Start time #2 with ▼ and ▲;
2. Can be adjusted from: end time #1 + 1 to the total regeneration duration minus 1 minute;
3. Press  to validate the selection and advance to the next parameter;
4. Set the relay End time #2 with ▼ and ▲;
5. Can be adjusted from: start time #2 + 1 to the total regeneration duration;
6. Press  to validate the selection and advance to the next parameter.

Activated 12 minutes after the regeneration started.

TIME BASED - START
TIME #2.

AUX. 1: TIME BASED - ...
12M

Deactivated 150 minutes after the regeneration started.

TIME BASED - END
TIME #2.

AUX. 1: TIME BASED - ...
150M

Volume based (Chemical pump)

Activate the relay output during the service for a preset duration based upon the volume of treated water.

Info



Only visible for metered systems if "volume based" was selected as auxiliary in the previous step.

This parameter has two steps.

The first one determines the volume which activates the relay.

The second one determines how long the relay has to be activated once the volume has passed.

1. Set the relay activation volume with ▼ and ▲;
2. Can be adjusted from: 1L to the total capacity of a service cycle excluding the reserve capacity.;
3. Press ► to validate the selection and advance to the next parameter.;
4. Set the relay activation duration with ▼ and ▲;
5. Can be adjusted from: 1 to 7200 seconds;
6. Press ► to validate the selection and advance to the next parameter.

Activates upon 1 L.

VOLUMEBASED-VOLUME-L.



Deactivates upon 10 minute.

VOLUMEBASED-DURATION-S.



6.2.5.29 Push settings

Select the desired Master Programming settings on one unit then push the same settings to all other connected units.

Info



Available only for multi-valves systems.

The ability to transmit settings from one unit to all other connected units. After push settings are complete, you may still make unique changes to individual units.

Options:

- off;
- on.

1. Select the push settings with ▼ and ▲;
2. Default setting: enabled;
3. Press ► to validate the selection and advance to the next parameter.

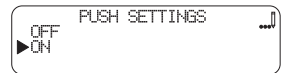

6.2.5.30 Save as non-factory

Info



Parameters set on master programming menu can be saved as a non-factory program.

This saved program will be restorable from the reset menu.

Options:

- off;
- on.

1. Select save as non-factory option with ▼ and ▲;
2. Default setting: disabled;
3. Press ► to validate the selection and advance to the next parameter.

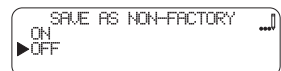

6.2.5.31 Lock options

Select the desired lock settings option (off, time based, delayed, or enter code).

Info



Lock Settings prevents unexpected access to master programming.

Once lock settings option is activated, the controller returns to normal service display.

The next time accessing the menu, the controller will call for either a password, or will grant access to menu only if programmed conditions are fulfilled.

Contact your supplier for more information.

Options:

- off;
- delayed;
- enter Code;
- time Based.

1. Select save as non-factory option with ▼ and ▲;

2. Default setting: disabled;

3. Press ▶ to validate the selection.



6.2.5.32 Parameters saving

Info



When the last parameter is set and the button ▶ pressed (after lock settings), the controller updates the database based on the new programming.

The main screen appears and valve status is initializing.

Wait until updating is finished, this may take a few seconds.

6.2.6 Diagnostic

6.2.6.1 Commands

Info



Depending on current settings, some displays cannot be viewed.

If none of the buttons are pushed for 5 minutes in the Diagnostic mode, or if there is a power failure, the controller returns to Service mode.

1. Press and hold ◀ to enter the Diagnostic mode.
2. Press ▶ to see the next data group or press ◀ to return to previous data group.
3. Press and hold ◀ to exit the Diagnostic mode at any time.

6.2.6.2 Flow rate

Info



The display is updated every second.

FLOW RATE
29.7 LPM



6.2.6.3 Peak flow rate

Info



The controller registers the highest flow rate since the last regeneration.

PEAK FLOW
30.1 LPM



6.2.6.4 Totalizer

Info



The controller registers the total volume of treated water that passes through the meter since start-up (or last hard reset).

1. To reset, press and hold the buttons ▼ and ▲ for 5 seconds until the display shows zero.

TOTALIZER
123 L



6.2.6.5 Reserve

Info



Shows the reserve capacity settings.

RESERVE
12 L



6.2.6.6 Use since regeneration

Info



Shows the volume at the outlet since last regeneration

USE SINCE REGEN
4 L



6.2.6.7 Valve address

Info



Shows the position of the valve in a multiple valve system.

ADDRESS
1

6.2.6.8 Last regeneration

Info



Shows the number of hours since the last regeneration, indicating the duration of the current service cycle.

LAST REGEN.
4H

6.2.6.9 Software version

Info



Shows the version of the software loaded in the controller.

Mandatory



In case of use of multiple valves system, verify the controller's software compatibility !

SOFTWARE VERSIO
1.0.1387

6.2.6.10 Number of regeneration

Info



Shows number of regeneration since installation.

NO. OF REGENS
2

6.2.6.11 Regeneration interval

Info



Shows duration between regenerations.

REGEN. INTRERUAL
5 D 0 H

6.2.6.12 Last settings change

Info



Shows when the last settings change occurred.

LAST SETTINGS CH
1H

6.2.6.13 Error log

Info



The last 20 error or alarm events are registered showing time and date of occurrences.

```

ERROR LOG
#20-2019-04-17 09:
▶ #1-2019-04-18 10:4
#2-2019-04-18 10:4
    
```

6.2.6.14 Sunday average daily usage

Info



Shows average water consumption on Sunday.

SUN - AVERAGE DAI
29 L

6.2.6.15 Sunday- daily usage

Info



Shows water consumption for the last 20 Sunday.

```

SUN - DAILY USAGE
2019-05-20 0 L
▶ 2019-04-12 0 L
2019-04-10 0 L
    
```

6.2.6.16 Monday average daily usage

Info



Shows average water consumption on Monday.

MON - AVERAGE DAI
29 L

6.2.6.17 Monday- daily usage

Info



Shows water consumption for the last 20 Monday.

MON - DAILY USAGE
2019-03-31 0 L
▶ 2019-04-13 0 L
2019-04-11 0 L

6.2.6.18 Tuesday average daily usage

Info



Shows average water consumption on Tuesday.

TUE - AVERAGE DAI
29 L

6.2.6.19 Tuesday- daily usage

Info



Shows water consumption for the last 20 Tuesday.

TUE - DAILY USAGE
2019-04-01 0 L
▶ 2019-04-14 0 L
2019-04-12 0 L

6.2.6.20 Wednesday average daily usage

Info



Shows average water consumption on Wednesday.

WED - AVERAGE DAI
29 L

6.2.6.21 Wednesday- daily usage

Info



Shows water consumption for the last 20 Wednesday.

WED - DAILY USAGE	
2019-04-02	0 L
▶ 2019-04-15	0 L
2019-04-13	0 L

6.2.6.22 Thursday average daily usage

Info



Shows average water consumption on Thursday.

THU - AVERAGE DAI	
29 L	

6.2.6.23 Thursday- daily usage

Info



Shows water consumption for the last 20 Thursday.

THU - DAILY USAGE	
2019-04-03	0 L
▶ 2019-04-16	0 L
2019-04-14	0 L

6.2.6.24 Friday average daily usage

Info



Shows average water consumption on Friday.

FRI - AVERAGE DAI	
29 L	

6.2.6.25 Friday- daily usage

Info



Shows water consumption for the last 20 Friday.

FRI - DAILY USAGE	
2019-04-04	0 L
▶ 2019-04-17	0 L
2019-04-15	0 L

6.2.6.26 Saturday average daily usage

Info



Shows average water consumption on Saturday.



6.2.6.27 Saturday- daily usage

Info



Shows water consumption for the last 20 Saturday.

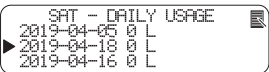

6.2.7 Resetting the controller

Mandatory



Once you have completed this operation, check all programming steps !

Info







There are two options to reset: reset to factory defaults or reset to Non-Factory Defaults.

Reset to factory defaults will set all the parameters to factory default values.

Reset to non-factory defaults will set all the parameters to previously saved default values.

Options:

- back: acces to main screen without resetting;
- reset to factory defaults;
- reset to non-factory defaults.

1. Power on the unit;
2. When Pentair's logo appears, press and hold ;
 - ⇒ The Reset menu appears;
3. Select reset option with  and ;
 - ⇒ Default setting: reset to factory defaults;
4. Press  to validate the selection.

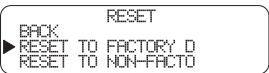

7 Commissioning

Info



This chapter is available for standard regeneration flows. Contact your supplier if the actual regeneration is not standard and if you need assistance.

7.1 Water filling, draining and waterproofness inspection

7.1.1 Activating a single valve system (System 4)

1. With the bypass still in Bypass position (inlet and outlet of the valve closed), plug in the NXT/NXT2 controller to the power source.
2. Proceed to programming according to system specification if not done yet.
3. Start a manual regeneration by pressing the regen button for 5 seconds. The piston will move into backwash position. Once in this position, unplug the NXT/NXT2 controller from the power source.
4. With the outlet manual valve still closed, slowly open the inlet manual valve. The valve and tank will slowly get filled with raw water, allowing air to be purged by the drain. Open the inlet progressively until fully open position.
5. Once the drain runs clear and the inlet manual valve fully open, plug in again the NXT/NXT2 controller to the power source.
6. Push on the regen button once to move the piston to the next regeneration cycle position. Leave the valve 1 minute in each position and move to the next one, until C4 or Cycle 4/5 is displayed. When C4 or Cycle 4/5 is displayed, let the valve run the entire cycle and check the level of water in the brine tank. The level of water in the brine tank should be about 5 cm above the salt platform. You may want to mark the level on the brine tank as this can be used as an indicator for the future lifetime of the softener.
7. Once C5 or Cycle 5/5 is completed, the valve will automatically go back into service position (unless non-standard regen sequence is programmed). Start again a manual regeneration by pressing for 5 seconds on the regen button. The valve will move to backwash position.
8. Press the regen button once to move to brine draw position. Check to see in the brine tank if the water level decreases.
9. Once the draw function is observed and confirmed (level of water in the brine tank has decreased), you may go through each cycle pushing on the regen button until C5 or Cycle 5/5, leave the water come back to the 'full' level, and then push on the regen button so that the valve returns into service position.
10. Slowly open the outlet manual valve, and close the bypass manual valve. The system is now in service.
11. Fill the brine tank with salt. You may want to mark the level of water in the brine tank when completely refilled with water and full of salt. In the future, after each regeneration, you can visually control that the quantity of water refilled should be between the 2 marks done. Marking are optional, but may allow to visually detect a irregularity during regeneration that may lead to softener inefficiency.

12. With the brine tank completely refilled and full of salt, adjust the safety brine valve in the brine well. Make sure the overflow elbow is installed above the float level and the discharge point.
13. After the softener has been running a few minutes in service, proceed to hardness test on outlet water to make sure the water is treated as per requirements.

7.1.2 Activating a multiple valves system (Systems 5, 6, 7, 8, 9 and 14)

1. Follow the previous procedure for each tank of the system.

Info



In order to save time, program first all tanks as single system 4.

Proceed to start up as described above for each tank, then program the correct system type and valve addresses (NXT only, NXT2 featuring automatic valve addressing) and eventually set/trip points in case of system 14.

7.1.2.1 Triplex and quadruplex system

After start up is complete and system is synchronized according to the system type program, adjust manually the tanks remaining capacities per tank in the diagnostic mode. If the capacity of all tanks in service are equal after start up, then the system could show the unwanted situation where several tanks are fully exhausted at the same time, leading to uncertain treated water quality for a short period. This can be avoided by manually balancing the capacities of the different tanks at start up. Note that this operation may require to be done regularly during normal service life of the system.

Example:

Assuming a triplex system 5 or 9. The valve with address 1, is set capacity at 50% of its real capacity in the diagnostic mode. The valve with address 2 is set it at 75% and the valve with address 3 is left at the real capacity. [Depending on the resin volume, you may also choose to balance on 33%, 66% and 100%]. The tanks in service will reach exhausted state at different moment.

Once regenerated, each tank will restart its cycle with 100% of its capacity as programmed.

The capacity adjustment in the diagnostic mode is valid only for the current cycle, it does not affect not modify the programmed system capacity.

7.2 Sanitization

7.2.1 Disinfection of water softeners

The materials of construction of the modern water softener will not support bacterial growth, nor will these materials contaminate a water supply. In addition, during normal use, a softener may become polluted with organic matter, or in some cases with bacteria from the water supply. This may result in an off-taste or odour in the water.

Thus, your softener may need to be disinfected after installation. Some softeners will require periodic disinfection during their normal lifetime. Consult your installing dealer for more information on disinfecting your softener.

Depending on the conditions of use, the softener type, the type of ion exchanger and the disinfectant available, a choice can be made among the following methods.

7.2.2 Sodium or calcium hypochlorite

These materials are satisfactory for use with polystyrene resins, synthetic gel zeolite, greensand and bentonites.

5.25% Sodium hypochlorite

If stronger solutions are used, such as those sold for commercial laundries, adjust the dosage accordingly.

Dosage

Polystyrene resin: set 1.25 mL fluid per 1 L of resin.

Non-resinous exchangers: set 0.85 mL fluid per 1 L.

Brine tank softeners

Backwash the softener and add the required amount of hypochlorite solution to the well of the brine tank. The brine tank should have water in it to permit the solution to be carried into the softener.

Proceed with the normal regeneration.

Calcium hypochlorite

Calcium hypochlorite, 70% available chlorine, is available in several forms including tablets and granules. These solid materials may be used directly without dissolving before use.

Do not let the disinfectant stand for more than 3 hours in the brine tank before the regeneration start.

Dosage

Measure two grains ~ 0.11 mL for 1 L.

Brine tank softeners

Backwash the softener and add the required amount of hypochlorite to the well of the brine tank. The brine tank should have water in it to permit the chlorine solution to be carried into the softener.

Proceed with the normal regeneration.

7.2.3 Electro chlorination

Valves or systems already equipped with an electrochlorinator device or system will be sanitized during the brine draw phase.

8 Operation

8.1 Display

8.1.1 NXT controller

8.1.1.1 During service

- Single valve in service in timeclock mode:

```
4#- SRV 15:25HR
REGEN EN 03 DAYS
```

- single valve in service in volume immediate or delayed mode:

```
4#- SRV* 14:24HR
VOLUME 8000L
```

- lead valve in regeneration queued in interlock system:

```
5#1 SRV* 10:15HR
VOLUME 25000L
```

- valve 3 in service in serial regeneration system:

```
6#3 SRV* 08:42HR
SYSUOL 45000L
```

8.1.1.2 During regeneration

During regeneration the display shows the cycle number and the time remaining for that cycle. The countdown for the time remaining starts only when the valve is in the cycle displayed.

- Cycle 1, time remaining 10 min:

```
CYCLE 1 00:10:00
```

- cycle 2, time remaining 1 hour 20 min:

```
CYCLE 2 01:20:00
```

- cycle 3, time remaining 50 min:

```
CYCLE 3 00:50:00
```

- cycle 4, time remaining 2 hours 40 min:

```
CYCLE 4 02:40:00
```

- cycle 5, time remaining 15 min:

```
CYCLE 5 00:15:00
```

8.1.2 NXT2 controller

8.1.2.1 During service

- Single valve in service in timeclock mode:

```
4  12:00HR
REGEN IN 4 D
```

- single valve in service in volume immediate or delayed mode:
- lead valve in regeneration queued in interlock system:
- window lock activated in serial regeneration system:
- remote lock activated in serial regeneration system:

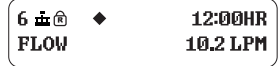

8.1.2.2 During regeneration

During regeneration the display shows the cycle number and the time remaining for that cycle. The countdown for the time remaining starts only when the valve is in the cycle displayed.

- The timer advance to regeneration cycle step #1:
- cycle step #1, time remaining 10 min:
- the timer advance to regeneration cycle step #2:
- cycle step #2, time remaining 1 hour 20 min:
- the timer advance to regeneration cycle step #3:
- cycle step #3, time remaining 50 min:
- the timer advance to regeneration cycle step #4:

During transition to cycle:

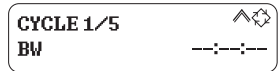

Once in position:



During transition to cycle:

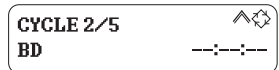

Once in position:

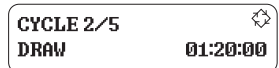

During transition to cycle:

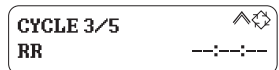

Once in position:

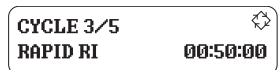

During transition to cycle:

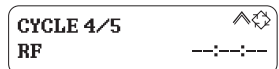

- cycle step #4, time remaining 2 hours 40 min:

Once in position:

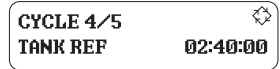

- the timer advance to regeneration cycle step #5:

During transition to cycle:

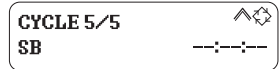

- cycle step #5, time remaining 15 min:

Once in position:

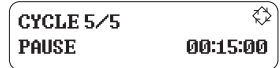

8.1.3 LED status

- Blue → the unit is in service and no errors detected;
- Blue flashing → the unit is in service with a queued regeneration;
- Green → the unit is in regeneration;
- Green flashing → the unit is in standby position, in a multi tank system;
- Red → the controllers have detected an error;
- All LED flashing → delayed unlock, only for NXT2.

8.2 Recommendations

- Use only regeneration salts designed for water softening in accordance with EN973;
- for optimal system operation, the use of clean salt, free from impurities, is recommended (for example salt pellets);
- do not use ice melt, block, or rock salts;
- the sanitizing process (both with liquid and electrochlorination) may introduce chlorine compounds which may reduce the lifetime of the ion exchange resins. Refer to the technical guides for resins in common use, providing necessary checks on the system.



8.3 Manual regeneration

Mandatory



The controller must be in service in order to enable this procedure !

8.3.1 Manual delayed regeneration

1. Press  (for NXT) or  (for NXT2) once for delayed regeneration.
 - ⇒ The regeneration starts on the programmed regeneration time. See chapter Regeneration start time [▶ Page 74] for NXT and chapter Regeneration time [▶ Page 105] for NXT2;
 - ⇒ For NXT: The blue LED flashes and the letters RGQ take place on the valve state;

⇒ For NXT2: The blue LED and the symbol  on the valve state flash.

Info





To cancel: press  (for NXT) or  (for NXT2) again.



For NXT: The blue LED stop flashing and the letters SRV take place on the valve status.

For NXT2: The blue LED and the symbol  stop flashing.

8.3.2 Immediate regeneration

1. Press and hold  (for NXT) or  (for NXT2) for 5 seconds to initiate immediate manual regeneration, regardless from the programmed regeneration mode.

8.3.3 To advance regeneration cycles

1. Press  (for NXT) or  (for NXT2) to pass to the next regeneration cycle.

8.3.4 To stop a regeneration (NXT2 only)

1. Press and hold  to stop the regeneration.

8.4 Operation during a power failure

- All the program settings are stored in a permanent memory;
- current valve position, cycle step time elapsed, and time of day are stored during a power failure, and will be restored upon power restoration;
- time is kept during a power failure and the time of day is adjusted upon restoration of the power (as long as the power is restored within 12 hours);
- the time of day on the main display screen will flash after a power failure once the power is restored until any button is pressed on the keyboard.

9 Maintenance

Mandatory



Cleaning, maintenance and service operation shall take place at regular intervals and must be done by qualified personnel only in order to guarantee the proper functioning of the complete system.

Report maintenance done in the Maintenance chapter of the User Guide document.

Failure in respecting above instructions may void the warranty!

9.1 General system inspection

Mandatory



Must be done, at minimum, once a year !

9.1.1 Water quality

9.1.1.1 Valve used for softening

1. Raw water total hardness.
2. Treated water hardness.

9.1.1.2 Valve used for filtration

1. Check for raw water analysis and filter's targeted contaminants concentration.
2. Check for treated water analysis and compare with raw water data.

9.1.2 Mechanical Checks

1. Inspect general condition of softener/filter and associated ancillaries and check for any leaks, ensure valve connection to piping is made with adequate flexibility as per manufacturer instruction.
2. Inspection of electrical connections, verify wiring connections and search for evidence of overloading.
3. Verify settings of electronic timer, verify regeneration frequency, and make sure the valve configuration is appropriate for media and tank size.
4. Check water meter, if present, report water meter settings and compare with previous inspection.
5. If water meter is present, verify total water consumption compared to previous visit.
6. If pressure gauges are installed before and after softening/filtering system, verify and record static and dynamic pressure, reporting pressure drop. Verify that inlet pressure respects valve and softening/filtering system limits. Verify that pressure drop stay stable year on year, adapt backwash duration if required.
7. If pressure gauges are not present, but suitable points exist, install temporary pressure gaug(s) to perform precedent point.

9.1.3 Regeneration test

9.1.3.1 Valve used for softening

1. Check condition of brine tank and any associated equipment.
2. Check salt level in brine tank.
3. Initiate regeneration test.
 - ⇒ Check brine draw during brine draw stage.
 - ⇒ Check brine tank refill.
 - ⇒ Check operation of safety brine valve, where fitted.
 - ⇒ Check for brine draw off levels.
 - ⇒ Check for resin loss at the drain during regeneration.
 - ⇒ Where fitted, check for satisfactory operation of solenoid, i.e. outlet shut off during regeneration and/or brine line shut off valve(s).
4. Test and record Total Hardness of outlet water from softener vessel(s).

9.1.3.2 Valve used for filtration

1. Initiate manual regeneration and observe flow to drain.
2. Make sure flow rate correspond to DLFC configuration.
3. Check for media loss at the drain during backwash.
4. Check to see if water runs clear at the end of the backwash cycle.
5. Observe flow fast rinse cycle and measure pressure drop through the filter system. Pressure drop after fast rinse should return equal or very close to pressure drop recorded after system start-up.
6. Where fitted, check for satisfactory operation of solenoid valve(s) i.e. outlet shut off during regeneration.

9.2 Recommended maintenance plan

9.2.1 Valve used for softening

Items	1 year	2 year	3 year	4 year	5 year
Injector & filter	Clean	Clean	Clean	Clean	Clean/ replace if necessary
BLFC***	Clean	Clean	Clean	Clean	Clean/ replace if necessary
DLFC***	Clean	Clean	Clean	Clean	Clean/ replace if necessary
Bypass (if present, contains Orings***)	Clean	Clean	Clean	Clean	Clean/replace if necessary
Piston*	Check/clean/ replace if necessary	Replace	Check/clean/ replace if necessary	Replace	Check/clean/ replace if necessary
Seals & spacers*	Check/clean/ replace if necessary	Replace	Check/clean/ replace if necessary	Replace	Check/clean/ replace if necessary
Brine valve	Check/clean/ replace if necessary	Check/clean/ replace if necessary	Check/clean/ replace if necessary	Check/clean/ replace if necessary	Replace
O-rings***	Check for watertightness /clean or replace in case of leakage	Check for watertightness /clean or replace in case of leakage	Check for watertightness /clean or replace in case of leakage	Check for watertightness /clean or replace in case of leakage	Check for watertightness /clean or replace in case of leakage
Motors	Check	Check	Check	Check	Replace
Gearing	Check	Check	Check	Check	Check/ replace if necessary
Inlet hardness	Check	Check	Check	Check	Check
Residual hardness	Check/adapt mixing screw if necessary	Check/adapt mixing screw if necessary	Check/adapt mixing screw if necessary	Check/adapt mixing screw if necessary	Check/adapt mixing screw if necessary
Electronic/ settings**	Check	Check	Check	Check	Check/ replace if necessary
Transformer**	Check	Check	Check	Check	Check/ replace if necessary
Microswitches	Check	Check	Check	Check	Replace
Meter(s)* (if present)	Check and Clean	Check and Clean	Check and Clean	Check and Clean	Replace
Meter cable(s)* (if present)	Check	Check	Check	Check	Replace

Items	1 year	2 year	3 year	4 year	5 year
Valve watertightness	Check	Check	Check	Check	Check
Valve to piping watertightness	Check	Check	Check	Check	Check

* Wear parts - durability strongly affected by raw water quality and regeneration frequency.

** Electronic parts - durability strongly affected by power source quality and stability.

*** Elastomer durability is strongly affected by raw water concentration in chlorine and its derivative.

9.2.2 Valve used for filtration

Items	1 year	2 year	3 year	4 year	5 year
DLFC***	Clean	Clean	Clean	Clean	Clean/ replace if necessary
Bypass (if present, contains Orings***)	Clean	Clean	Clean	Clean	Clean/replace if necessary
Piston*	Replace	Replace	Replace	Replace	Replace
Seals & spacers*	Replace	Replace	Replace	Replace	Replace
O-rings***	Check for watertightness /clean or replace in case of leakage	Check for watertightness /clean or replace in case of leakage	Check for watertightness /clean or replace in case of leakage	Check for watertightness /clean or replace in case of leakage	Check for watertightness /clean or replace in case of leakage
Motors	Check	Check	Check	Check	Replace
Gearing	Check	Check	Check	Check	Check/ replace if necessary
Electronic/ settings**	Check	Check	Check	Check	Check/ replace if necessary
Transformer**	Check	Check	Check	Check	Check/ replace if necessary
Microswitches	Check	Check	Check	Check	Replace
Meter(s)* (if present)	Check and Clean	Check and Clean	Check and Clean	Check and Clean	Replace
Meter cable(s)* (if present)	Check	Check	Check	Check	Replace
Valve watertightness	Check	Check	Check	Check	Check
Valve to piping watertightness	Check	Check	Check	Check	Check

* Wear parts - durability strongly affected by raw water quality and regeneration frequency.

** Electronic parts – durability strongly affected by power source quality and stability.

*** Elastomer durability is strongly affected by raw water concentration in chlorine and its derivative.

9.3 Recommendations

9.3.1 Use original spare parts

Caution - material



Risk of damage due to use of non-genuine spare parts !

To ensure correct operation and safety of the device, only use original spare parts and accessories recommended by the manufacturer.

Usage of non-genuine spare parts voids all warranties.

Parts to keep in stock for potential replacements are the pistons, S&S kit, injectors, micro-switches and motors. Refer to maintenance sheet.

9.3.2 Use original approved lubricants

- Dow Corning #7 Release Agent.

9.3.3 Maintenance instructions

- Disinfect and clean the system at least once a year or if the treated water has an off-taste or an unusual odor;
- perform a hardness test every year of both inlet and treated water.

9.4 Cleaning and maintenance

9.4.1 First steps

Before any cleaning or maintenance procedure, complete the following steps:

Mandatory



These operations must be performed before any cleaning or maintenance procedure !

1. Unplug the wall-mounted transformer.
2. Shut off water supply or put bypass valve(s) into bypass position.
3. Relieve system pressure before performing any operations.

9.4.2 Power head and/or motor replacement

9.4.2.1 Valve with NXT controller

Info



As the DC motor is equipped with an AC to DC converter, AC and DC motors can be used with the NXT controller.

1. Using a flat screwdriver, unscrew (1) and open the cover (2).
2. Disconnect the motor (11).
3. Unscrew (9) and remove the micro-switches with their support (10).
4. Using a Philips screwdriver, unscrew (5) and open the controller (8).
5. Using pliers, remove the retaining clip (3) and the circlip (6).
6. Remove the pin (4) and the plate (7).
7. Using pliers, remove the circlip (15) and the wheel (14).
8. Using a flat screwdriver unscrew (13).
9. Using a wrench, unscrew (12) and remove the motor (11).
10. Reverse above procedure steps to rebuild

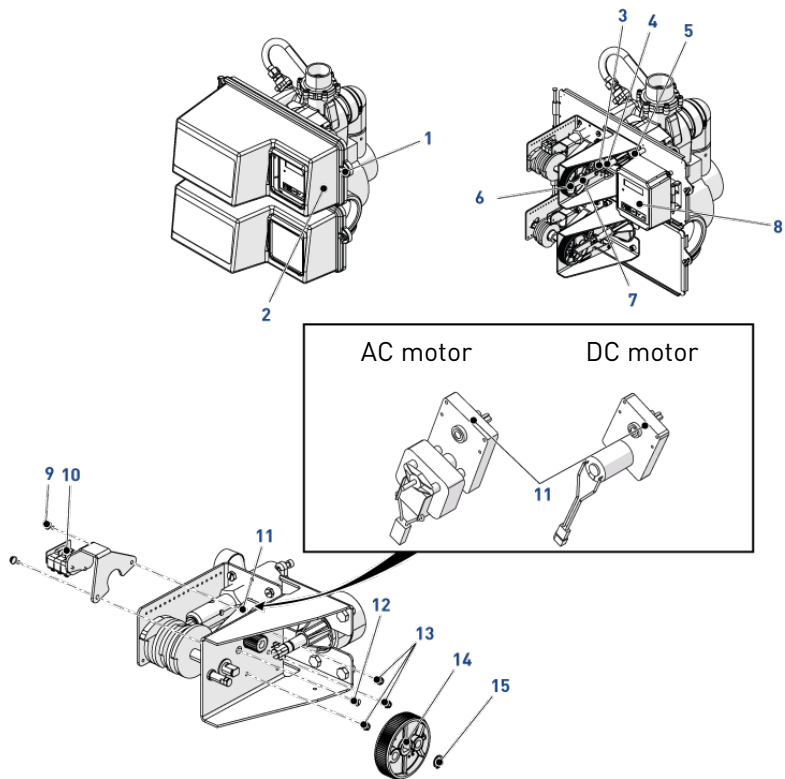

9.4.2.2 Valve with NXT2 controller

Caution - material



Risk of damage due to AC motor use !

Use only DC motor with NXT2 controller.

1. Using a flat screwdriver, unscrew (1) and open the cover (2).
2. Disconnect the motor (10).
3. Unscrew (8) and remove the micro-switches with their support (9).
4. Open the controller (7).
5. Using pliers, remove the retaining clip (3) and the circlip (5).
6. Remove the pin (4) and the plate (6).
7. Using pliers, remove the circlip (14) and the wheel (13).
8. Using a flat screwdriver unscrew (12).
9. Using a wrench, unscrew (11) and remove the motor (10).
10. Reverse above procedure steps to rebuild

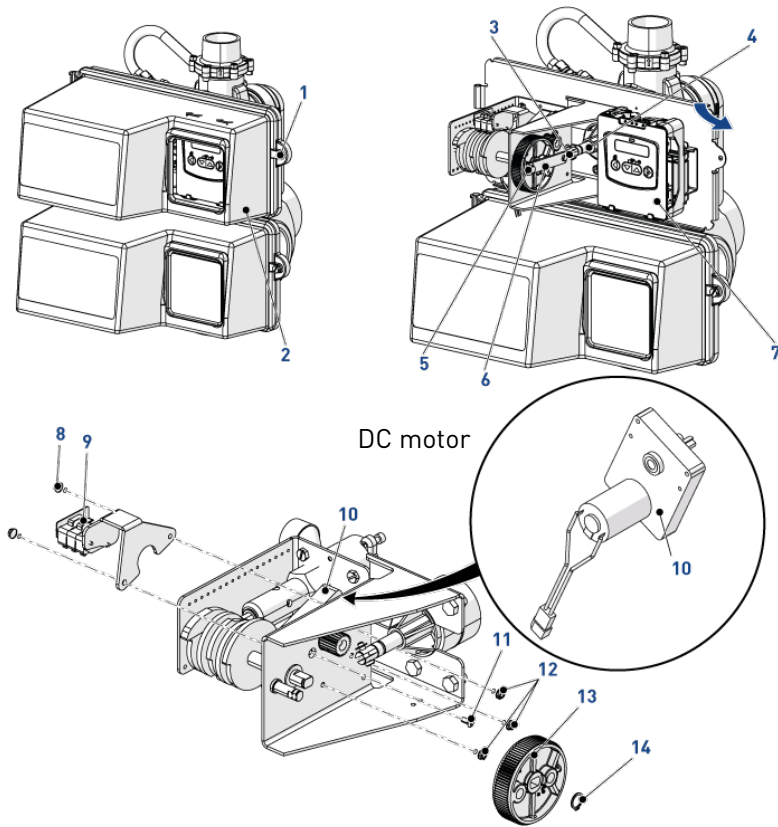

9.4.3 Lower power head motor replacement

Caution - material



Risk of damage due to AC motor use !

Use only DC motor with NXT2 controller.

Info



As the DC motor is equipped with a AC to DC converter, AC and DC motors can be used with the NXT controller.

1. Using a flat screwdriver, unscrew (1) and open the cover (2).
2. Disconnect the motor (9).
3. Unscrew (7) and remove the micro-switches with their support (8).
4. Using pliers, remove the retaining clip (3) and the circlip (5).
5. Remove the pin (4) and the plate (6).
6. Using pliers, remove the circlip (13) and the wheel (12).
7. Using a wrench unscrew (11).
8. Using a wrench, unscrew (10) and remove the motor (9).
9. Reverse above procedure steps to rebuild

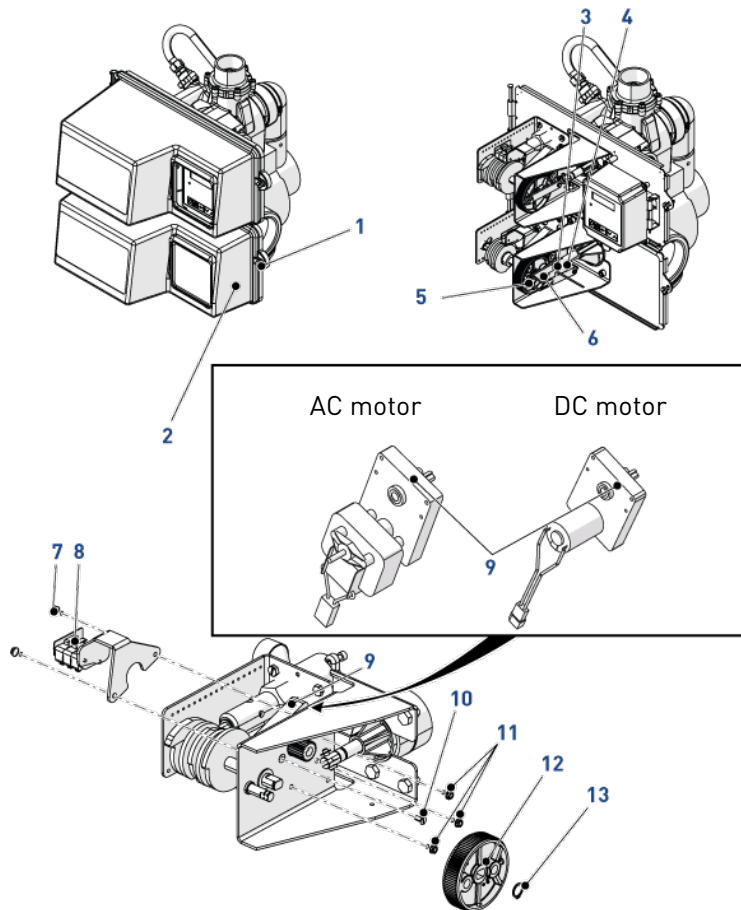

9.4.4 NXT to NXT2 controller upgrade

Mandatory



As NXT2 controller functions only with DC motors, in case of NXT to NXT2 controller upgrade, the AC motor must be changed for a DC motor !

1. Using a flat screwdriver, unscrew (1) and open the cover (2).
2. Using a flat screwdriver, unscrew (5) and open the NXT controller (9).
3. Disconnect the AC motor (11).
4. Remove the pin (6), the O-ring (10) and the NXT controller (9).
5. Remove the micro-switches (13), see Micro-switches replacement [► Page 146].
6. Using pliers, remove the retaining clip (3) and the circlip (7).
7. Remove the pin (4) and the plate (8).
8. Using pliers, remove the circlip (17) and the wheel (16).
9. Using a flat screwdriver unscrew (14).
10. Using a wrench, unscrew (15) and remove the **AC** motor (11).
11. Fit the **DC** motor (12) in place and using a screwdriver screw (14).
12. Using a wrench, screw (15).
13. Fit the wheel (16) in place and fix the circlip (17) using pliers.
14. Fit the plate (8) with the pin (4) in place.
15. Using pliers, fix the retaining clip (3) and the circlip (7).
16. Fit the micro-switches (13) in place, see Micro-switches replacement [► Page 146].
17. Using the pin (6) and the O-ring (10) fit the NXT2 controller holder (18) in place.
18. Connect the NXT2 controller (19), see NXT2 controller connections [► Page 55].
19. Clip the NXT2 controller (19) in the controller holder (18).
20. Close the NXT2 controller (19).
21. Close the cover (2) and using a flat screwdriver screw (1).
22. Change the lower power head AC motor for a DC motor, see Lower power head motor replacement [► Page 137].

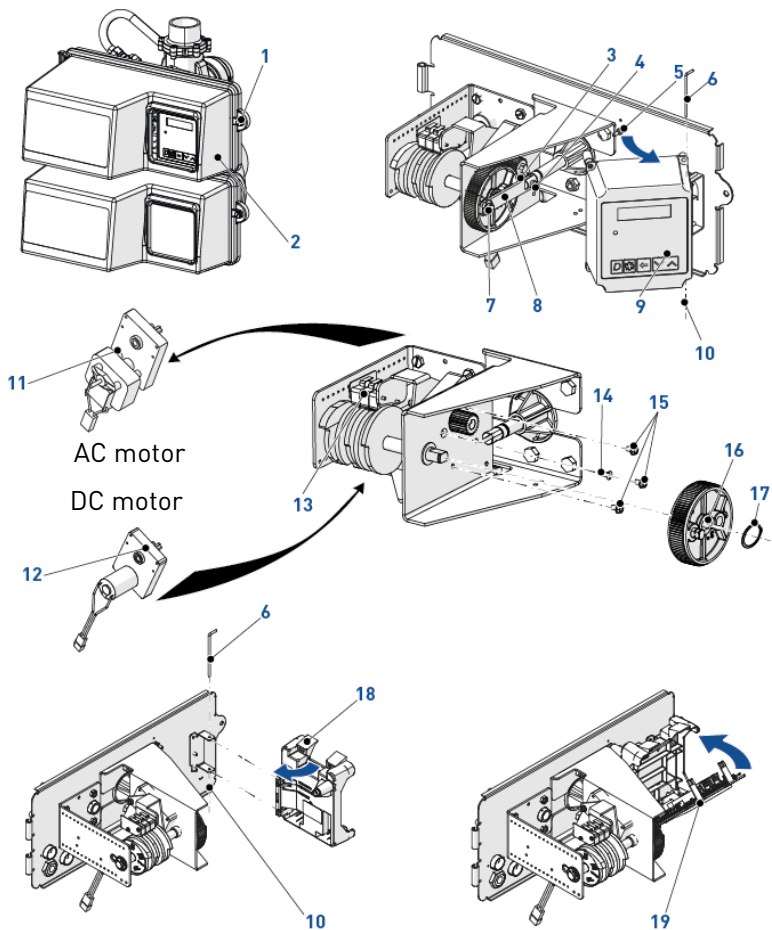

9.4.5 NXT2 controller replacement

1. Using a flat screwdriver, unscrew (1) and open the cover (2).
2. Press on the clips (3) and remove the controller (4).
3. Disconnect the controller (4).
4. Connect the new NXT2 controller (5), see NXT2 controller connections [▶ Page 55].
5. Clip the new NXT2 controller (5) in the controller holder (6).
6. Close the cover (2) and using a flat screwdriver screw (1).

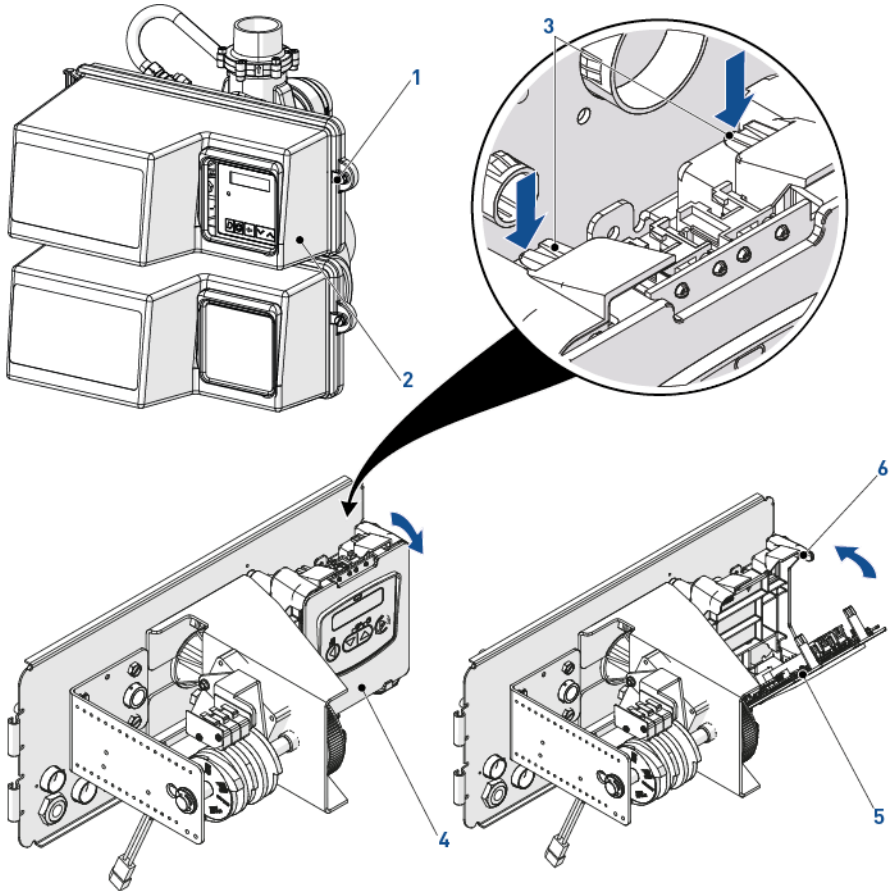

9.4.6 Upper piston and/or seal and spacer kit disassembly/replacement

1. Using a flat screwdriver, unscrew (1) and open the cover (2).
2. Using pliers, remove the clip (6) and the connecting pin (7).
3. Using a 32 mm wrench, unscrew (3).
4. Using a 10 mm wrench, unscrew (4) and remove the power head (5).
5. Using pliers, remove the piston (10).

Caution - material



Risk of damage on piston due to wrench use !

Using a wrench on piston rod coating will cause leakages.

6. Using a small hook, remove a seal (12).
7. Using the puller, remove a spacer (8 or 9).
8. Repeat the two previous steps for all the seals and spacers.
9. Lubricate each new seals (12).
10. Put back a seal (12) using the stuffer.
11. Put back a spacer (8 or 9) using the stuffer.

Mandatory



Respect the order of the spacers shown on the sketch.

12. Repeat the two previous steps for all the seals and spacers.
13. Lubricate the piston O-ring (11).
14. Put back the piston (10).
15. Follow the procedure four first steps in reverse order to rebuild.

Caution - material



Risk of damage due to wrong lubricant use !

Do not use petroleum-based lubricants such as vaseline, oils, or hydrocarbon-based lubricants.

Use only approved silicone grease or soapy water !

9.4.6.1 Special tools needed

1

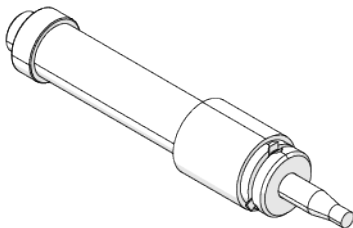

2

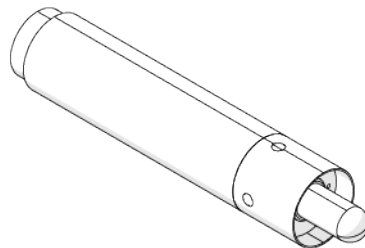

Item	Part number	Description	Packaging quantity
1	12682	Puller 2"	1
2	12683	Stuffer 2"	1

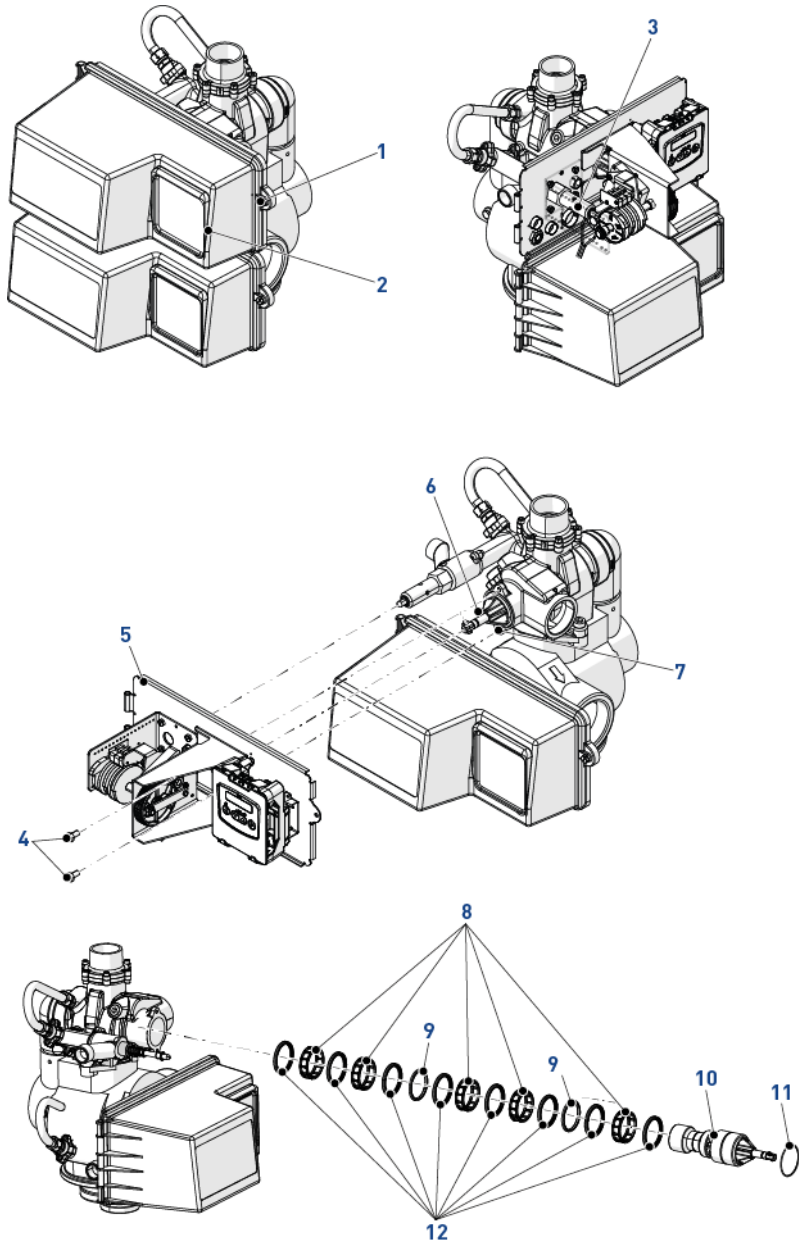

9.4.7 Lower piston and/or seal and spacer kit replacement

1. Using a flat screwdriver, unscrew (1) and open the cover (2).
2. Using pliers, remove the clip (5) and the connecting pin (6).
3. Using a 10 mm wrench, unscrew (3) and remove the power head (4).
4. Using pliers, remove the piston (9).

Caution - material



Risk of damage on piston due to wrench use !

Using a wrench on piston rod coating will cause leakages.

5. Using a small hook, remove a seal (7).
6. Remove a spacer (8 or 11).
7. Repeat the two previous steps for all the seals and spacers.
8. Lubricate each new seals (7).
9. Put back a seal (7).
10. Put back a spacer (8 or 11).

Mandatory



Respect the order of the spacers shown on the sketch.

11. Repeat the two previous steps for all the seals and spacers.
12. Lubricate the piston o-ring (10).
13. Put back the piston (9).
14. Follow the procedure three first steps in reverse order to rebuild.

Caution - material



Risk of damage due to wrong lubricant use !

Do not use petroleum-based lubricants such as vaseline, oils, or hydrocarbon-based lubricants.

Use only approved silicone grease or soapy water !

Info



No special tools are needed to change the seals and spacers from the lower piston. The hole is big enough to do it with the hands.

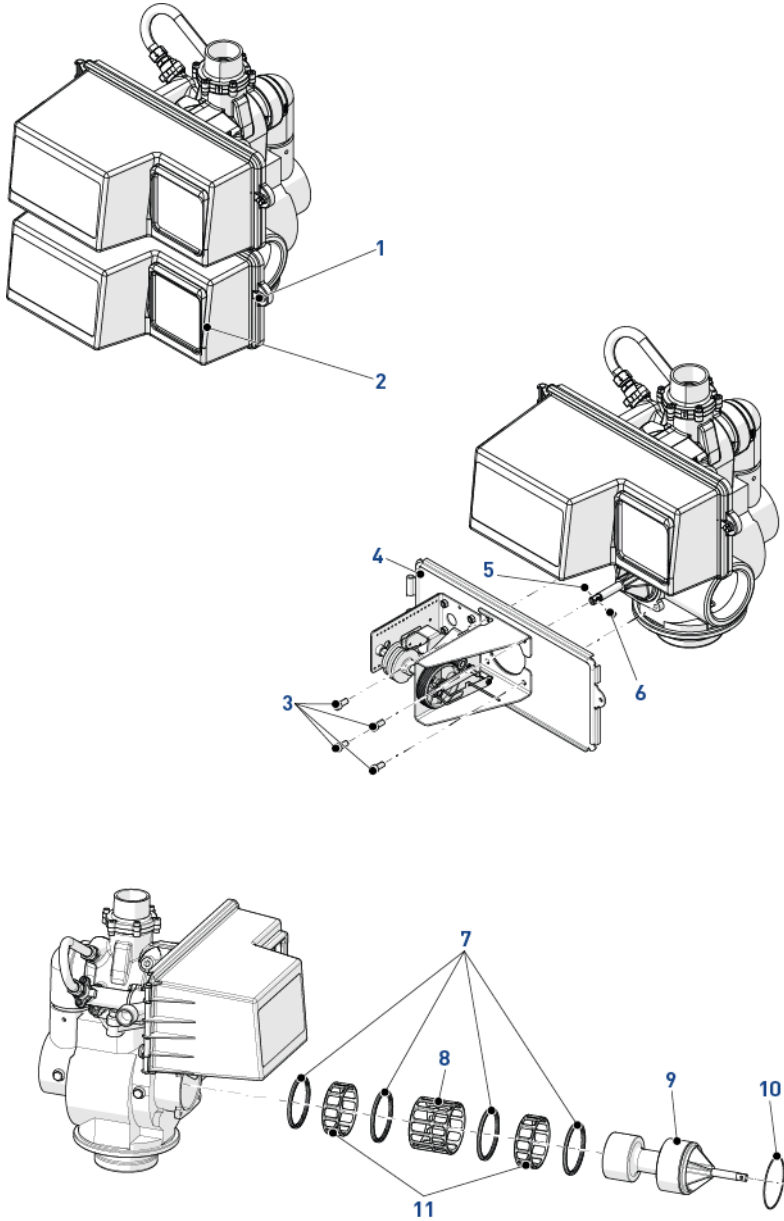

9.4.8 Micro-switches replacement

1. Using a flat screwdriver, unscrew (1) and open the cover (2).
2. Using a Phillips screwdriver, unscrew (3) and extract the protection plates (4) and the micro-switches (5).
3. Reverse above procedure steps to rebuild.

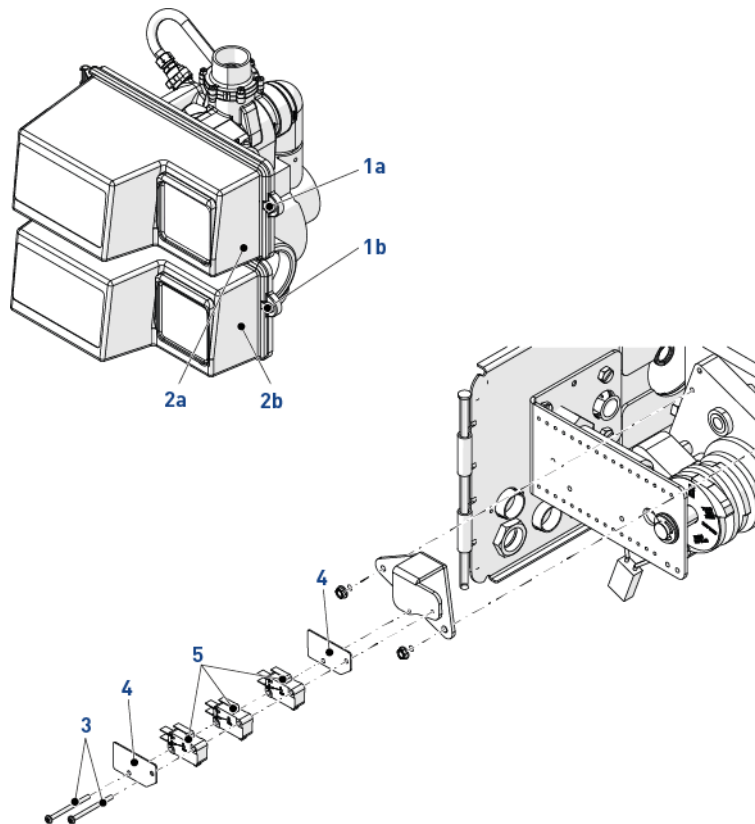

9.4.9 Cams replacement

1. Using a flat screwdriver, unscrew (1) and open the cover (2).
2. Remove the micro-switches (3), see Micro-switches replacement [▶ Page 146].
3. Disconnect the motor (4).
4. For NXT2 controller, open the controller (7) by pulling it. And for NXT controller, open the controller (7) using a Philips screwdriver.
5. Using pliers, remove the clip (5) and the connecting pin (6).
6. Using pliers, remove the circlip (12) and the wheel (11).
7. Using a 10 mm wrench, unscrew (9) and remove the plate (10) and the camshaft (8).
8. Using a pin punch, remove the pin (13).
9. Reverse above procedure steps to rebuild.

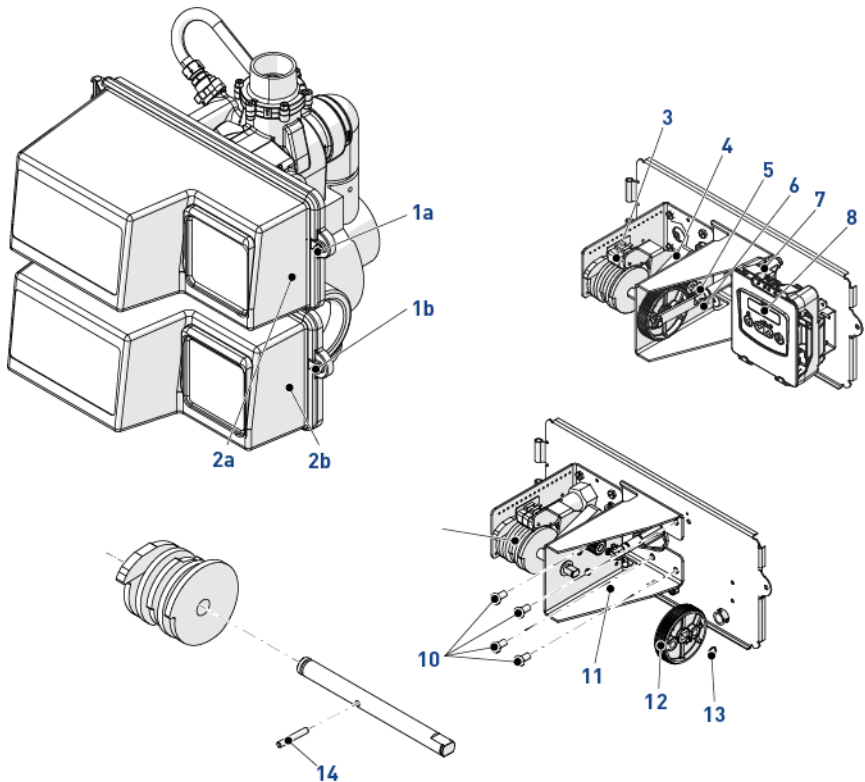

9.4.10 Injector throat and washer cleaning

1. Using a 4 mm Allen wrench, unscrew (1).
2. Using a 24 mm wrench, remove the tube (10).
3. Using a 4 mm Allen wrench, unscrew (11) and remove the connector (9), the o-ring (8) and the injector nozzle (7).
4. Using a 4 mm Allen wrench, unscrew (5) and remove the T-tube (6), the o-rings (3 and 12), the injector throat (4) and the injector washer (2).
5. Clean the injector throat (4) and the injector washer (2) using compressed air, a soft brush or possibly a pin.
6. Lubricate on the o-rings (3), (8) and (12) using silicone grease.
7. Reverse above procedure steps to rebuild.

Mandatory



The injector washers (2) have to be installed with their chamfered side upfront the water stream flow.

Flow indication must be visible after the injector washer (2) is placed on the seat (4).

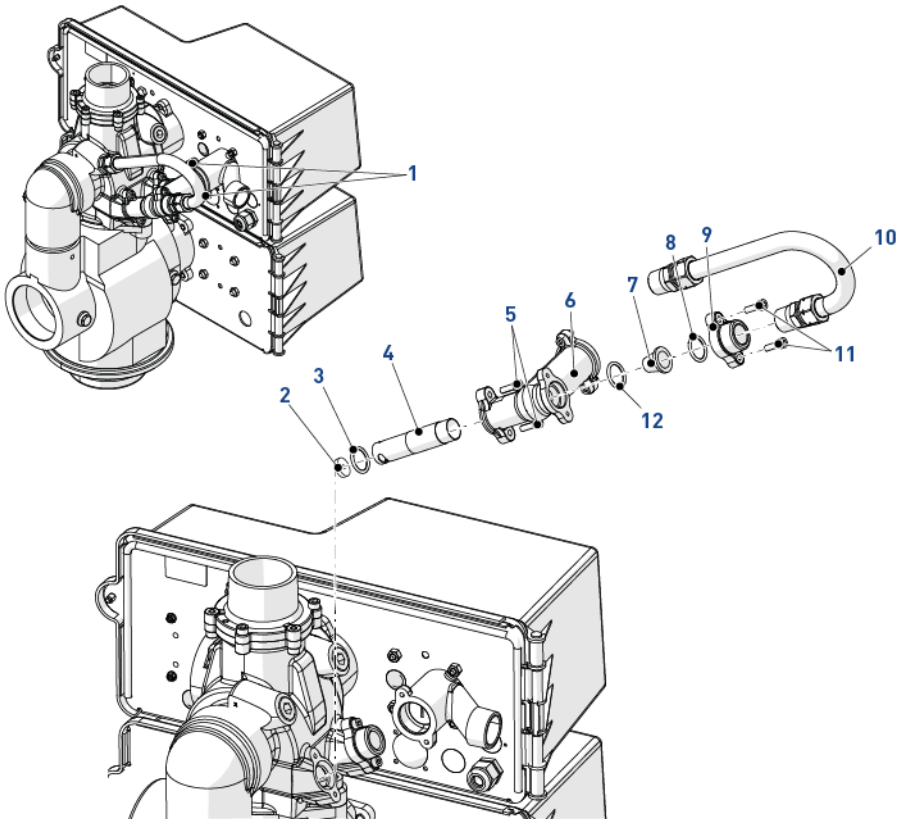

9.4.11 BLFC cleaning

1. Using a 34 mm wrench, remove the flow control housing (1) from the valve.
2. Using pliers, remove the retaining ring (6), the flow control retainer (5), the washer holder (3) and the washer (4).
3. Remove the washer (4) from washer holder (3).
4. Clean or change the washer (4).
5. Lubricate the seal (2) with approved silicone lubricant only.
6. Follow the procedure three first steps in reverse order to rebuild.

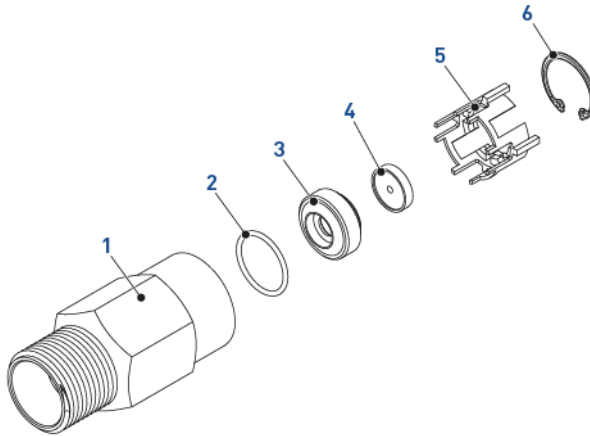

9.4.12 DLFC cleaning

1. Using a 5 mm Allen wrench, unscrew (1) and remove the housing (2).
2. Remove the cover plate (4) and the seat (6).
3. Remove the washers (5) from the seat (6).
4. Clean or change the washers (5).
5. Lubricate the seal (3) with approved silicone lubricant only.
6. Follow the procedure three first steps in reverse order to rebuild.

Mandatory



The washers (5) have to be installed with their chamfered side upfront the water stream flow.

Flow indication must be visible after the washer (5) is placed on the seat (6).

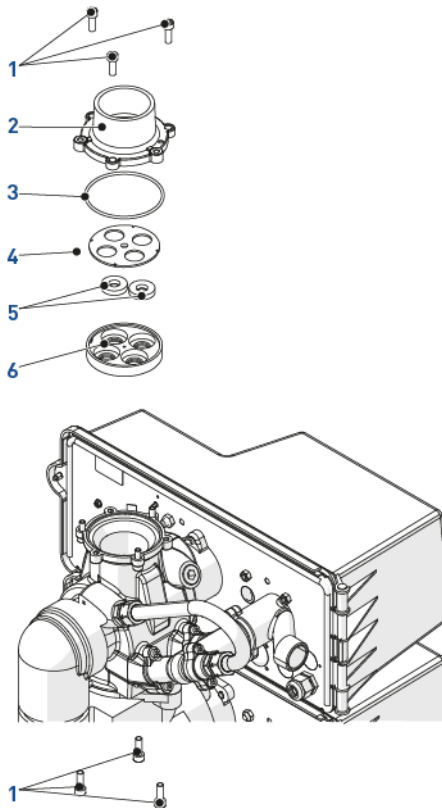

9.4.13 Valve on tank assembly

1. Lubricate the seals with approved silicone grease.
2. Spin the valve (1) onto the tank (2), ensuring the threads are not cross-threaded.
3. Rotate the valve (1) clockwise and freely, without using force until it comes to a stop.

Info



This stop position is considered point zero.

4. Rotate the valve (1) clockwise from point zero to between $\frac{1}{4}$ turn and $\frac{1}{2}$ turn.

Caution - material



Risk of damage due to excessive force !

Do NOT exceed 27 Nm of torque when installing the valve. Exceeding this limit may damage the threads and cause failure.

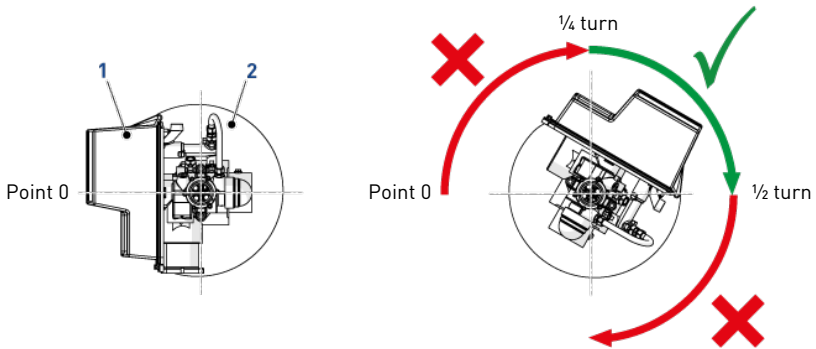

10 Troubleshooting

10.1 Error detection

Info





It can take up to 30 seconds before an error can be detected and displayed.

Mandatory



All the errors must be displayed on each controller before they can be corrected !

- If an error is detected, the status LED light will be red;
- during an error condition, the unit continues to monitor flow and update the remaining capacity. Once an error condition is corrected, the unit returns to the operating status it was in prior to the error, and regeneration resumes according to normal programming;
- if an error is cleared by reprogramming the unit in the Master Programming Mode, the volume remaining may be reset to the full unit capacity (as though it had just regenerated);
- if an error is present, a regeneration can only occur manually by pressing and holding  or  for 5 seconds;
- if the unit was in regeneration when the error occurred, it completes the regeneration cycle and goes to service;
- when the problem is corrected, and the error no longer displays (it may take several seconds for the unit to stop displaying the error message), the unit returns to normal operation. The status LED light is no longer Red, and turns Green if the unit is regenerating, or Blue if the unit is in service.

Problem	Cause	Solution
Water softener fails to regenerate	Electrical service to unit has been interrupted.	Assure permanent electrical service (check fuse, plug, switch...).
	Timer is defective.	Replace controller.
	Power failure.	Reset time of day.

Problem	Cause	Solution
Hard water	By-pass valve is open.	Close by-pass valve.
	No salt is in brine tank.	Add salt to brine tank and maintain salt level above water level.
	Injector screen plugged.	Clean injector screen.
	Insufficient water flowing into brine tank.	Check brine tank fill time and clean brine line flow control if pugged.
	Leak at the distributor tube.	Make sure distributor tube is not cracked. Check o-ring and tube pilot.
	Internal valve leak.	Replace seals and spacers and/or piston.
Excessive salt consumption	Improper salt setting.	Check salt usage and salt setting.
	Excessive water in brine tank.	See problem "Excessive water in brine tank" below.
Controller cycles continuously	Maladjusted, broken or shorted micro-switch.	Determine if micro-switch or controller is faulty and replace it, or replace complete power head.
Loss of water pressure	Iron buildup in line to water softener.	Clean line to water softener.
	Iron buildup in water softener.	Clean controller and add mineral cleaner to mineral bed. Increase frequency of regeneration.
	Inlet of softener plugged due to foreign material broken loose from pipes by recent work done on plumbing system.	Remove piston and clean the piston chamber.
Loss of mineral through drain line	Air in water system.	Assure that well system has proper air eliminator control. Check for dry well condition.
	Improperly sized drain line flow control.	Check for proper drain rate.
Iron in conditioned water	Fouled mineral bed.	Check backwash, brine draw and brine tank refill. Increase frequency of regeneration. Increase backwash time.

Problem	Cause	Solution
Excessive water in brine tank	Plugged drain line flow control.	Clean flow control.
	Plugged injector system.	Clean injector and screen.
	Controller is not cycling.	Replace controller.
	Foreign material in brine valve.	Replace brine valve seat and clean valve.
	Foreign material in brine line flow control.	Clean brine line flow control.
Softener fails to draw brine	Drain line flow is plugged.	Clean drain line flow control.
	Injector is plugged.	Clean injector.
	Injector screen is plugged.	Clean screen.
	Line pressure is too low.	Increase line pressure to 1.4 bar.
	Internal valve leaks.	Change seals, spacers and piston assembly.
	Cam did not cycle.	Check drive motor and micro-switches.
Drain flows continuously	Controller is not programming correctly.	Check controller program and positioning of controls. Replace power head assembly if not positioning properly.
	Foreign material in valve body.	Remove power head assembly and inspect bore. Remove foreign material and check valve body in various regeneration positions.
	Internal valve leak.	Replace seals and piston assembly.

10.2 Programming error

If reprogramming the unit clears the error, the remaining volume may be reset to full unit capacity (as if it had just regenerated).

- All the units in service remain in service;
- all the units in standby go to service;
- when the error appears, the unit in regeneration finishes the regeneration and goes to service;
- no regeneration starts while the error condition remains.

When the programming problem is corrected and the error is no longer displayed (it may take several seconds for all the units of the system to stop displaying the error), the system returns to normal operation.

Some examples of programming errors detected are:

- valve address doubled;
- power failure;

- system size: ex. programmed for 4 units, but there are only 2 units;
- units of measure do not correspond between the different valves of the system;
- wrong type of valve programmed.

Cause	Solution
More than one unit programmed with the same position number.	Program correctly the units using only once per position number.
Flashing display.	There was a power failure.
Units of measure do not correspond: units have different units of measure programmed.	Check and program all units in the system with the same units of measure.
System size: the number of units in the system does not correspond to the number programmed and vice versa.	Check to make sure that system number and number of units correspond.

10.3 Examples of error displayed

10.3.1 NXT controller

- The unit 2 has been reset;
 - Reprogram the unit.
- there is no message from unit 3;
 - The number indicate the unit to be checked in the system.
 - Check that communication cables are connected.
 - Check the valve address.
- there are more units in the system than programmed in the lead (#1) unit;
- the programmed values do not match, check the values programmed in each unit;
 - Example: Display format different from one unit to the other.
 - Example: System of 4 units, but only 2 detected or connected.
- programmed position of units incorrect.
 - Lead unit (#1) not programmed.
 - 2 or more units are programmed with the same address.

```
DETECTED ERROR =
E2      RESET UNIT
```

```
ERROR DETECTED
NO      MESSAGE 3
```

```
ERROR DETECTED
SYSTEM SIZE !
```

```
ERROR DETECTED
ERROR PROGRAM
```

```
ERROR DETECTED
ADDRESS OK
```

10.3.2 NXT2 controller

- Number of NXT2 detected does not match selected system type in Master Programming;
 - Push correct valve settings in Master Settings and check wiring.

```
ERROR 
VALUE COUNT MISMATC
```

- the motor is on but no encoder pulses are detected or CAM Switches change state within a given duration;
 - Verify correct valve type is chosen. Trigger a manual regeneration.
- motor current exceeds thresholds;
 - Call your supplier.
- flow exceeded specified threshold for a specific duration;
 - Call water treatment specialist.
- during a setting push, a packet was missing;
 - Reconnect communication cables and push setting in Master Settings.
- the system type among connected units does not match;
 - Push correct system settings in Master Settings. Check all programming steps without changing settings.
- hardware or software error;
 - Call your supplier.
- 100 Days have expired without a regeneration;
 - Trigger a manual regeneration. Check user programming, meter cable and meter functionality.

MOTOR RUN-ON ⓘ
NO CAM SWITCH CHANGE

OVER-CURRENT ⓘ
MOTOR OVER-CURRENT

FLOW METER ERROR ⓘ
CONTINUOUS FLOW DET

ERROR ⓘ
SEND/RECEIVE FAIL

ERROR ⓘ
SYSTEM TYPE MISMATCH

MICROCONTROLLER ER ⓘ

100 DAYS WITHOUT REG ⓘ

11 Spare parts and options

11.1 Valve parts list

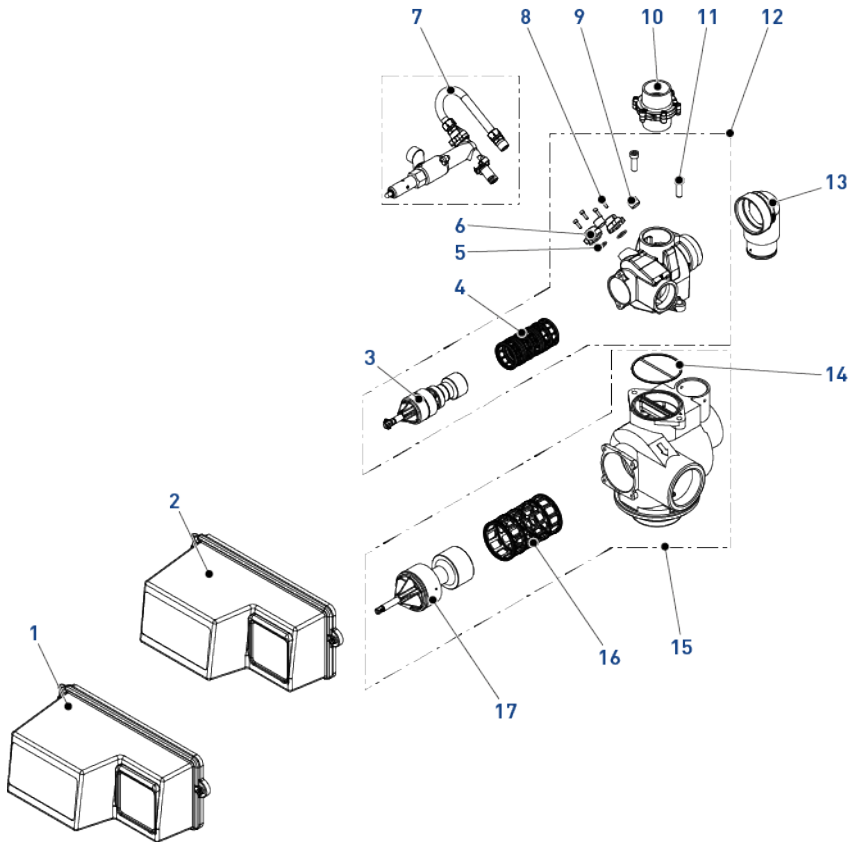

Item	Part number	Description	Packaging quantity
1	PH3900-001	PH 3900 24V/50Hz grey w/o timer	1
-	PH3900-002	PH 3900 adapt 24V/50Hz	1
-	PH3900-007	PH 3900 adapt NXT	1
2	PH3150-001	PH 3150 24V/50Hz grey without timer	1
-	PH3150-002	PH 3150 NXT 24V/50Hz	1
3	60106-00	Piston assy 3150/3900 upper DF	1
-	60106-10	Piston assy 3150 up flow	1
4	18022	S&S kit 2930/3150/3900 upper	1
5	15246-01SP	O-ring 560 CD	10
6	16341-02	Injector plug 1800	1

Item	Part number	Description	Packaging quantity
7	26745-4	BV 1800 assy 3900 DF	1
-	26745-5	BV 1800 assy 3900 DF	1
-	26745-6	BV 1800 assy 3900 DF	1
-	26745-7	BV 1800 assy 3900 DF	1
-	26745-8	BV 1800 assy 3900 DF	1
-	26745-9	BV 1800 assy 3900 DF	1
-	26745-10	BV 1800 assy 3900 DF	1
8	19677SP	Screw	50
9	16387	VB plug 1/2" NPT 3150/3900	1
10	25580-ALL	DLFC kit 2" 3150/3900 30 to 100 gpm	1
11	25165SP	Screw THM 12x35	10
12	BU28517-01	VB assy 3900 DF	1
	BU28517-02	VB assy 3900 UF	1
13	18044	Coupling 3900 assy	1
14	15112	Seal 3150 adapt base	1
15	18043	VB adapt assy 3900 DF	1
-	18042	VB adapt assy 3900 NBP	1
16	18064	S&S kit 3900 lower	1
17	60107-00	Piston assy 3900 lower	1
-	60107-10	Piston assy 3900 lower NBP	1

11.2 Power head 3150 parts list

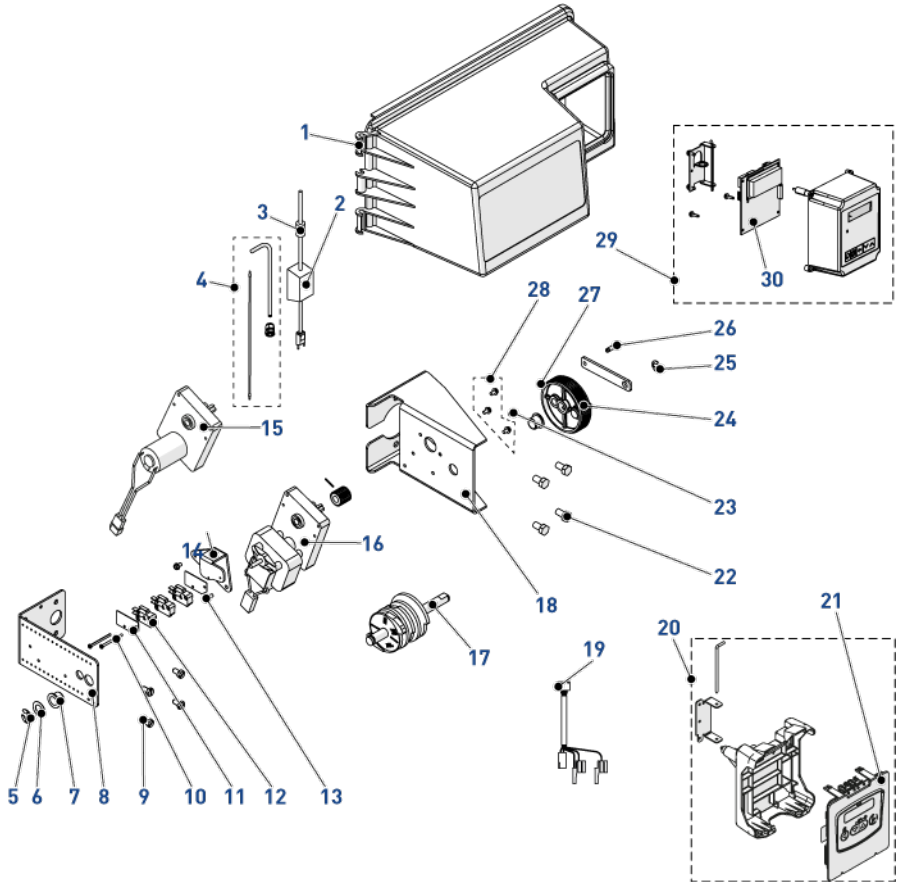

Item	Part number	Description	Packaging quantity
1	26637	Cover assy 3150 upper grey	1
2	26259	Transformer 24 VAC 105 VA (for 3900)	
-	26260	Transformer 24 VAC, 60 VA (for 3150)	1
-	44415	Transformer 24 VDC	1
3	17967	Liquid tight	1
4	25352	Guide cable & cable assy 3150 2"	1
5	16051SP	Retaining ring	10
6	16059SP	Washer	10
7	16052SP	Bushing	10
8	16053	Bracket brine side	1

Item	Part number	Description	Packaging quantity
9	23728SP	Screw THM 6x12	8
10	40080SP	Screw microswitch	10
11	10302SP	Insulator limit switch	10
12	10218SP	Microswitch	5
13	10872SP	Screw motor mounting	10
14	17797	Bracket switch mounting	1
15	29212	Drive motor assy 3150 24 VDC	1
16	28409-01	Drive motor assy 3150 24 VAC	1
-	28409-03	Drive Motor assy 3150/3900 230 VAC	1
17	16494-04	Cam assy 3150 upper up flow grey	1
-	16494-05	Cam assy 3150 upper down flow black	1
18	15120-01	Bracket motor 3150	1
19	40941	Wire Harness, upper driver	1
20	21594	Timer NXT2 assy	1
21	21595	Front panel assy NXT2	1
22	21361SP	Screw TCHCM 8x16	10
23	11080SP	Screw flat head	10
24	18963-31	Drive gear 3150 adapter	1
25	16050SP	Retaining ring	10
26	11709	Pin link 3150	1
27	11898SP	Clip 3150	10
28	10872SP	Screw Motor Mounting	50
29	BU28713	Controller assy NXT	1
30	BR61702-03	Circuit board NXT	1

11.3 Lower power head parts list

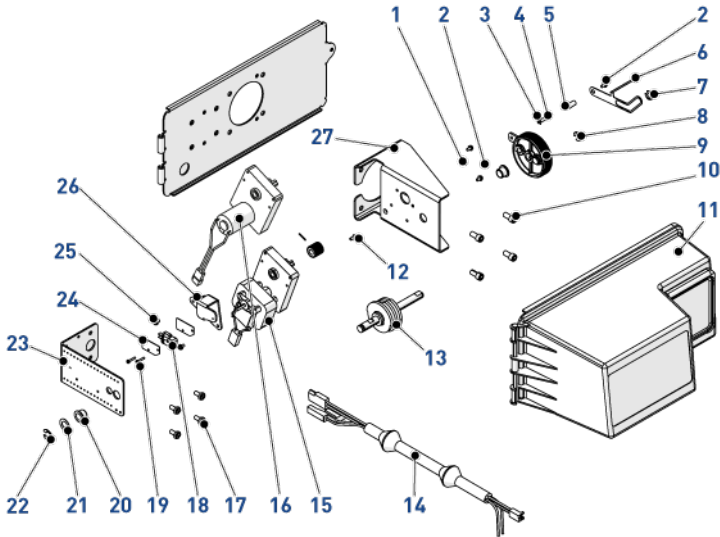

Item	Part number	Description	Packaging quantity
1	10872SP	Screw motor mounting	50
2	11080SP	Screw motor mounting	50
3	11898SP	Clip 3150/3900	50
4	11709	Connecting rod pin	1
5	18726-50SP	Spacer indicator	10
6	19315	Indicator off line/on line 3900	1
7	11774SP	Retaining ring	10
8	16050SP	Retaining ring	10
9	18963-39	Drive gear 3900 adapt	1
10	21361SP	Screw TCHCM 8x16	50
11	BU26638	Cover assy grey 3900 lower	1
12	11080SP	Screw flat head	50
13	16495	Cam assy 3900 lower	1
14	BR42446	Harness lower drive (ex 40405)	1
-	40943	Harness 3200NT lower	1
15	28409-01	Drive motor assy 3150 24VAC	1
-	28409-03	Drive Motor assy 3150/3900 230VAC	1
16	29212	Drive motor assy 3150 24VDC	1
17	10231SP	Screw hex head industrial	50
18	10218SP	Microswitch	5

Item	Part number	Description	Packaging quantity
19	11805SP	Screw microswitch	50
20	16052SP	Bushing	10
21	16059SP	Washer	10
22	16051SP	Retaining ring	10
23	16053	Bracket brine side	1
24	10302SP	Insulator limit switch	50
25	10872SP	Screw motor mounting	50
26	17797	Bracket switch mounting	1
27	16086	Bracket motor 3900	1

11.4 1800 injector parts list

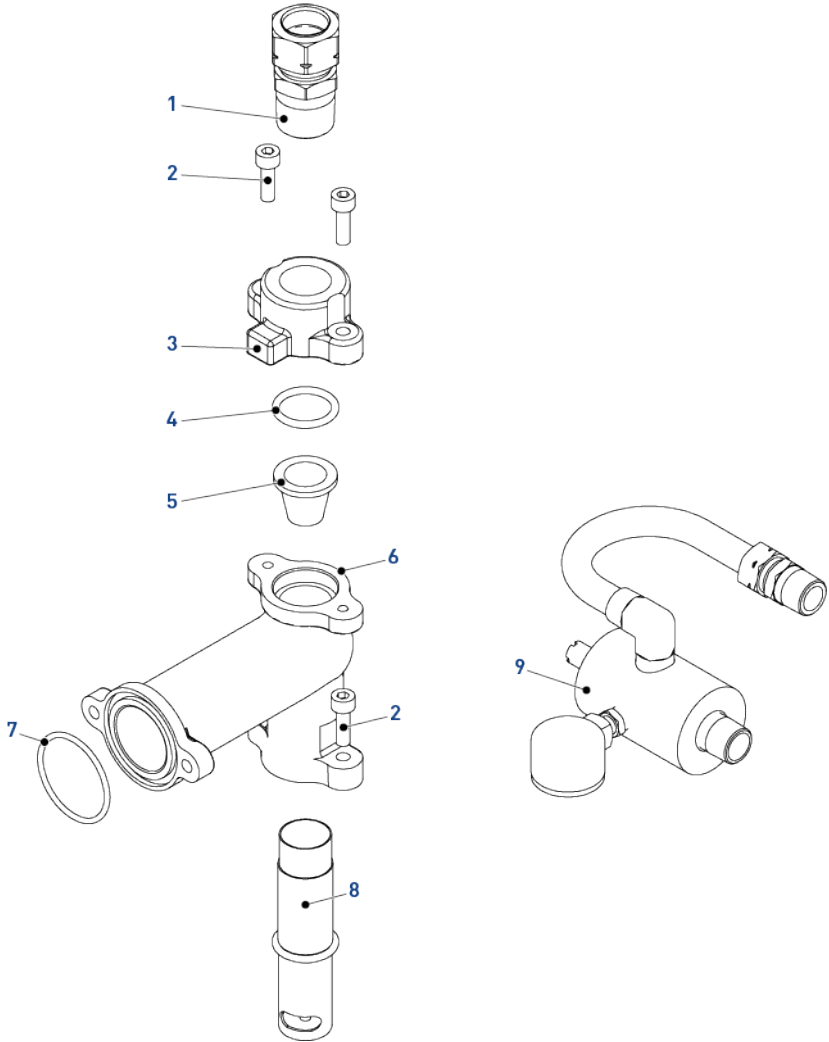

Item	Part number	Description	Packaging quantity
1	18702	Fitting, tube 1/2 NPT 5/8	1
2	19677SP	Screw	10
3	16341-01	Inj cover 1800	1
4	15246-01SP	O-ring - 560CD	1
5	15128-04SP	Injector nozzle 4	1
-	15128-05SP	Injector nozzle 5	1

Item	Part number	Description	Packaging quantity
-	15128-06SP	Injector nozzle 6	1
-	15128-07SP	Injector nozzle 7	1
-	15128-08SP	Injector nozzle 8	1
-	15128-09SP	Injector nozzle 9	1
-	15128-10SP	Injector nozzle 10	1
6	16340-20	Injector body DF	1
-	16340-21	Injector body UF	1
7	19054SP	O-ring	1
8	15127-04	Injector throat 4	1
-	15127-05	Injector throat 5	1
-	15127-06	Injector throat 6	1
-	15127-07	Injector throat 7	1
-	15127-08	Injector throat 8	1
-	15127-09	Injector throat 9	1
-	15127-10	Injector throat 10	1
9	60734	Pressure regulator assy 3150/3900	1

11.5 BLFC parts list

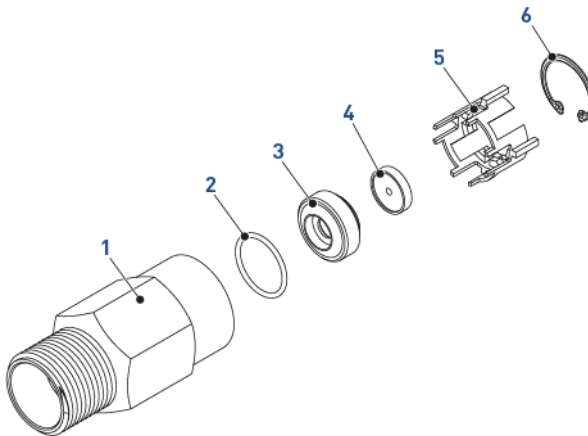

Item	Part number	Description	Packaging quantity
1	BR16530	Flow control housing	1
2	19292SP	O-ring 022	10
3	19053	Flow control retainer 1.5 to 7 gpm	1
-	19279	Flow control retainer 10 to 20 gpm	1

Item	Part number	Description	Packaging quantity
4	12086SP	Washer, flow 1.5 gpm	10
-	12087SP	Washer, flow 2.0 gpm	10
-	12089SP	Washer, flow 3.0 gpm	10
-	12090SP	Washer, flow 3.5 gpm	10
-	12092SP	Washer, flow 5.0 gpm	10
-	12408SP	Washer, flow 7.0 gpm	10
-	16529SP	Washer, flow 10.0 gpm	5
-	16736SP	Washer, flow 15.0 gpm	5
-	16528SP	Washer, flow 20.0 gpm	5
5	16738SP	Flow control retainer	10
6	16805SP	Retaining ring	10

11.6 DLFC parts list

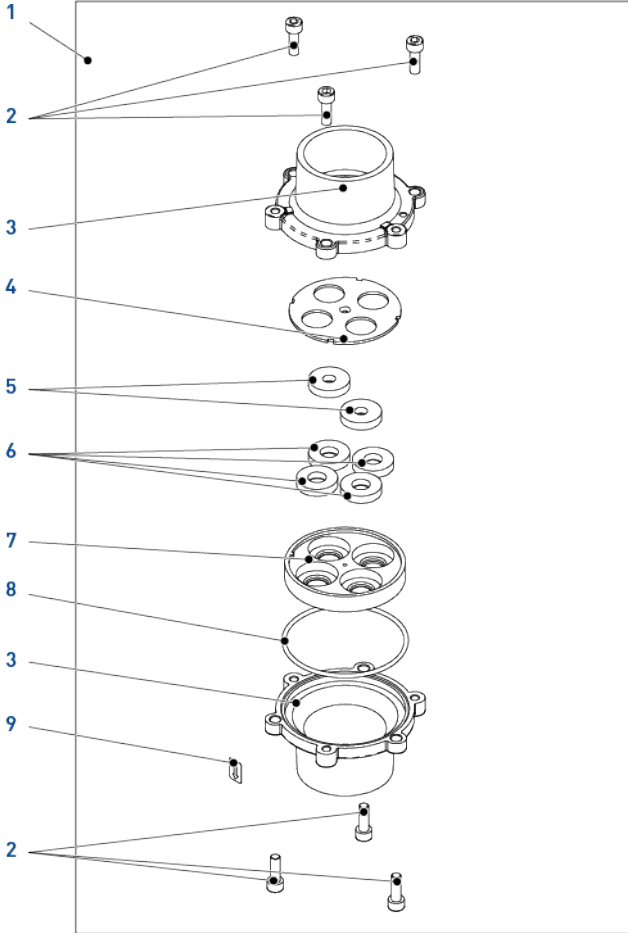

Item	Part number	Description	Packaging quantity
1	25580-ALL	2" DLFC assy 3150/3900 (30-100 gpm)	1
2	25177	Screw	10
3	27913-21	2" Flow control housing - BSP	2
4	16650	Plate, DLFC cover	1
5	16529	Flow controller washer 10 gpm	2
6	16736	Flow controller washer 15 gpm	4
-	16528	Flow controller washer 20 gpm	4
-	16737	Flow controller washer 25 gpm	4
7	16649	Holder DLFC button	1

Item	Part number	Description	Packaging quantity
8	16804	O-ring	1
9	BU28656	Label	1

11.7 Safety brine valves list

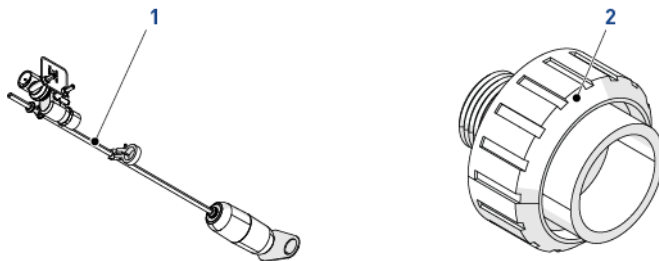

Item	Part number	Description	Packaging quantity
1	25453	SBV 2350 - without air check	5
2	28182	Union PVC female 1" to be glued - male 1" BSP	5

11.8 Distribution systems parts list

Caution - material



Respect the valve sizing configuration to avoid the resin to leak through the valve !

The 0.2 mm and 0.3 mm slots are used for softening systems and the 0.5 mm slots are used for filtering systems.

11.8.1 Flanged 6", tanks 30" - 36", TM, slots 0.3 mm

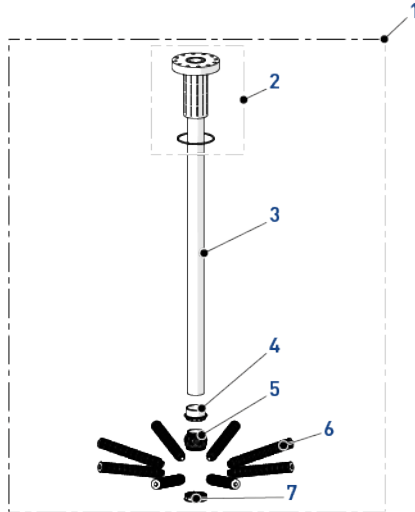

Item	Part number	Description	Packaging quantity
1	A-TF30-025	Distribution system assy, tanks 30"	1
-	A-TF36-025	Distribution system assy, tanks 36"	1
2	A-3100-11C	Adapter	1
3	A-PIPE-90	Riser tube 1850 mm	1
4	AB-GC8-30	Reducing bush	1
5	ATD-H80-00	Hub	1
6	A-TH02-268	Lateral 268 mm, tanks 30"	6
-	A-TH02-330	Lateral 330 mm, tanks 36"	6
7	AD-H80-00	Hub cap	1

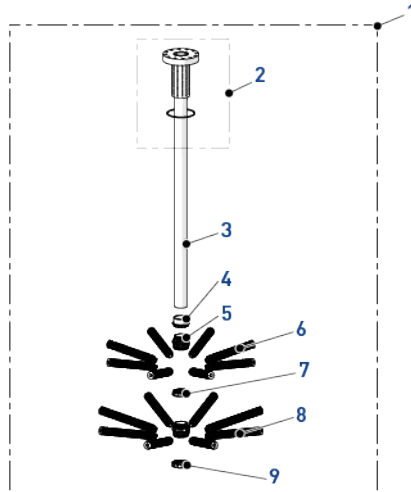
11.8.2 Flanged 6", tanks 42" - 48", TM, slots 0.3 mm

Item	Part number	Description	Packaging quantity
1	A-TF42-025	Distribution system assy, tanks 42"	1
-	A-TF48-025	Distribution system assy, tanks 48"	1
2	A-3100-11C	Adapter	1
3	A-PIPE-90	Riser tube 1850 mm	1
4	AB-GC8-30	Reducing bush	1
5	ATD-H80-00	Hub	2
6	A-TH02-423	Lateral 423 mm, tanks 42"	8
-	A-TH02-485	Lateral 485 mm, tanks 48"	8
7	AB-C08-40	Connection	1
8	A-TH02-361	Lateral 361 mm, tanks 42"	8
-	A-TH02-423	Lateral 423 mm, tanks 48"	8
9	AD-H80-00	Hub cap	1

11.8.3 Flanged 6", tanks 42" - 63", TM & SM, bottom distribution, DN100 connections

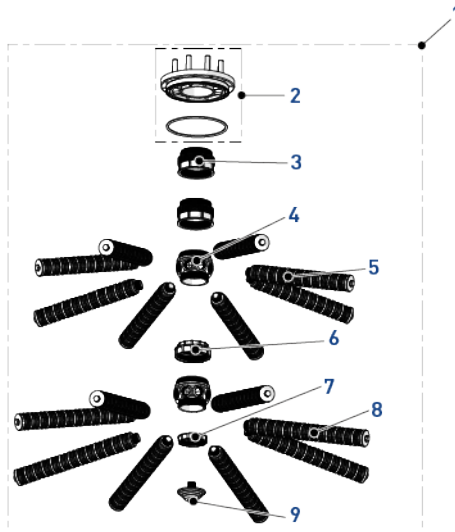

Item	Part number	Description	Packaging quantity
1	A-ST10042-02	Distribution system assy, DN100, slots 0.2 mm, tanks 42"	1
-	A-ST10042-05	Distribution system assy, DN100, slots 0.5 mm, tanks 42"	1
-	A-ST10048-02	Distribution system assy, DN100, slots 0.2 mm, tanks 48"	1
-	A-ST10048-05	Distribution system assy, DN100, slots 0.5 mm, tanks 48"	1
-	A-ST10055-02	Distribution system assy, DN100, slots 0.2 mm, tanks 55"	1
-	A-ST10055-05	Distribution system assy, DN100, slots 0.5 mm, tanks 55"	1
-	A-ST10063-02	Distribution system assy, DN100, slots 0.2 mm, tanks 63"	1
-	A-ST10063-05	Distribution system assy, DN100, slots 0.5 mm, tanks 63"	1
2	A-3100-09C	Adapter DN100	1
3	A-3100-05C	Prolongation	2
4	ATD-H80-00	Hub	2
5	A-TH02-361	Lateral 361 mm, slots 0.2 mm, tanks 42"	8
-	A-TH05-361	Lateral 361 mm, slots 0.5 mm, tanks 42"	8
-	A-TH02-423	Lateral 423 mm, slots 0.2 mm, tanks 48"	8
-	A-TH05-423	Lateral 423 mm, slots 0.5 mm, tanks 48"	8
-	A-TH02-516	Lateral 516 mm, slots 0.2 mm, tanks 55"	8
-	A-TH05-516	Lateral 516 mm, slots 0.5 mm, tanks 55"	8
-	A-TH02-578	Lateral 578 mm, slots 0.2 mm, tanks 63"	8
-	A-TH05-578	Lateral 578 mm, slots 0.5 mm, tanks 63"	8

Item	Part number	Description	Packaging quantity
6	AB-C08-40	Connection	1
7	A-BTC8-30	Hub cap	1
8	A-TH02-423	Lateral 423 mm, slots 0.2 mm, tanks 42"	8
-	A-TH05-423	Lateral 423 mm, slots 0.5 mm, tanks 42"	8
-	A-TH02-485	Lateral 485 mm, slots 0.2 mm, tanks 48"	8
-	A-TH05-485	Lateral 485 mm, slots 0.5 mm, tanks 48"	8
-	A-TH02-578	Lateral 578 mm, slots 0.2 mm, tanks 55"	8
-	A-TH05-578	Lateral 578 mm, slots 0.5 mm, tanks 55"	8
-	A-TH02-640	Lateral 640 mm, slots 0.2 mm, tanks 63"	8
-	A-TH05-640	Lateral 640 mm, slots 0.5 mm, tanks 63"	8
9	A-2727-10	Filter nozzle	1

11.8.4 Flanged 6", tanks 42" - 63", SM, top distribution, DN80 connections

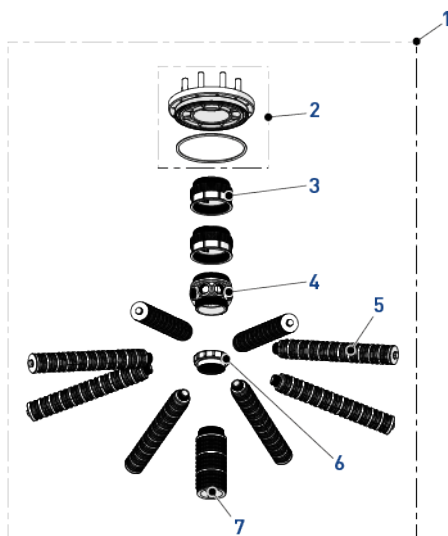

Item	Part number	Description	Packaging quantity
1	A-2742-FU	Distribution system assy, DN80, slots 0.2 mm, tanks 42"	1
-	A-2542-FU	Distribution system assy, DN80, slots 0.5 mm, tanks 42"	1
-	A-2748-FU	Distribution system assy, DN80, slots 0.2 mm, tanks 48"	1
-	A-2548-FU	Distribution system assy, DN80, slots 0.5 mm, tanks 48"	1
-	A-2755-FU	Distribution system assy, DN80, slots 0.2 mm,tanks 55"	1
-	A-2555-FU	Distribution system assy, DN80, slots 0.5 mm,tanks 55"	1
-	A-2763-FU	Distribution system assy, DN80, slots 0.2 mm, tanks 63"	1

Item	Part number	Description	Packaging quantity
-	A-2563-FU	Distribution system assy, DN80, slots 0.5 mm, tanks 63"	1
2	A-3100-03C	Adapter DN80	1
3	A-3100-05C	Prolongation	2
4	ATD-H80-00	Hub	1
5	A-TH02-361	Lateral 361 mm, slots 0.2 mm, tanks 42"	8
-	A-TH05-361	Lateral 361 mm, slots 0.5 mm, tanks 42"	8
-	A-TH02-423	Lateral 423 mm, slots 0.2 mm, tanks 48"	8
-	A-TH05-423	Lateral 423 mm, slots 0.5 mm, tanks 48"	8
-	A-TH02-516	Lateral 516 mm, slots 0.2 mm, tanks 55"	8
-	A-TH05-516	Lateral 516 mm, slots 0.5 mm, tanks 55"	8
-	A-TH02-578	Lateral 578 mm, slots 0.2 mm, tanks 63"	8
-	A-TH05-578	Lateral 578 mm, slots 0.5 mm, tanks 63"	8
6	AB-C08-30	Connection	1
7	A-2740	Diffuser, slots 0.2 mm	1
-	A-2746	Diffuser, slots 0.5 mm	1

11.8.5 Flanged 6", tanks 42" - 63", SM, bottom distribution, DN80 connections

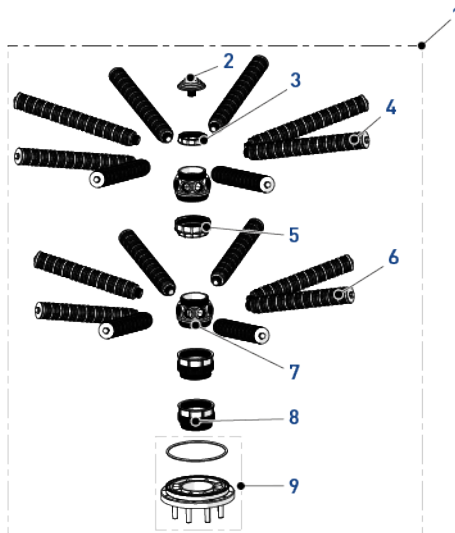

Item	Part number	Description	Packaging quantity
1	A-2742-FL	Distribution system assy, DN80, slots 0.2 mm, tanks 42"	1
-	A-2542-FL	Distribution system assy, DN80, slots 0.5 mm, tanks 42"	1
-	A-2748-FL	Distribution system assy, DN80, slots 0.2 mm, tanks 48"	1

Item	Part number	Description	Packaging quantity
-	A-2548-FL	Distribution system assy, DN80, slots 0.5 mm, tanks 48"	1
-	A-2755-FL	Distribution system assy, DN80, slots 0.2 mm,tanks 55"	1
-	A-2555-FL	Distribution system assy, DN80, slots 0.5 mm,tanks 55"	1
-	A-2763-FL	Distribution system assy, DN80, slots 0.2 mm, tanks 63"	1
-	A-2563-FL	Distribution system assy, DN80, slots 0.5 mm, tanks 63"	1
2	A-2727-10	Filter nozzle	1
3	A-BTC8-30	Hub cap	1
4	A-TH02-423	Lateral 423 mm, slots 0.2 mm, tanks 48"	8
-	A-TH05-423	Lateral 423 mm, slots 0.5 mm, tanks 48"	8
-	A-TH02-485	Lateral 485 mm, slots 0.2 mm, tanks 55"	8
-	A-TH05-485	Lateral 485 mm, slots 0.5 mm, tanks 55"	8
-	A-TH02-578	Lateral 578 mm, slots 0.2 mm, tanks 63"	8
-	A-TH05-578	Lateral 578 mm, slots 0.5 mm, tanks 63"	8
-	A-TH02-640	Lateral 640 mm, slots 0.2 mm, tanks 63"	8
-	A-TH05-640	Lateral 640 mm, slots 0.5 mm, tanks 63"	8
5	AB-C08-40	Connection	1
6	A-TH02-361	Lateral 361 mm, slots 0.2 mm, tanks 42"	8
-	A-TH05-361	Lateral 361 mm, slots 0.5 mm, tanks 42"	8
-	A-TH02-423	Lateral 423 mm, slots 0.2 mm, tanks 48"	8
-	A-TH05-423	Lateral 423 mm, slots 0.5 mm, tanks 48"	8
-	A-TH02-516	Lateral 516 mm, slots 0.2 mm, tanks 55"	8
-	A-TH05-516	Lateral 516 mm, slots 0.5 mm, tanks 55"	8
-	A-TH02-578	Lateral 578 mm, slots 0.2 mm, tanks 63"	8
-	A-TH05-578	Lateral 578 mm, slots 0.5 mm, tanks 63"	8
7	ATD-H80-00	Hub	2
8	A-3100-05C	Prolongation	1
9	A-3100-03C	Adapter DN80	1

11.9 Tank adapters parts list

11.9.1 Flanged 6", tanks adapter, TM

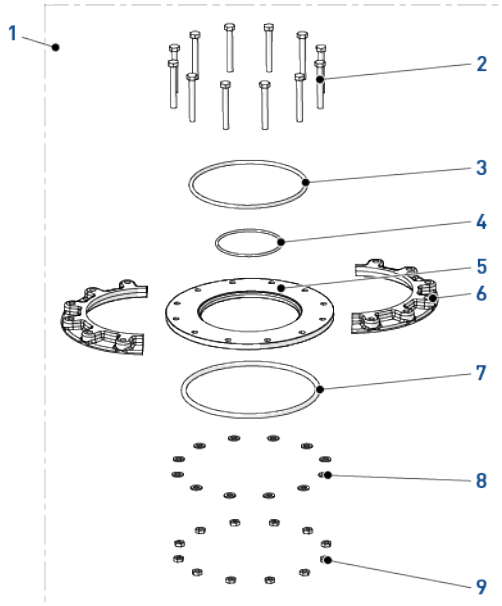

Item	Part number	Description	Packaging quantity
1	18925	Tank adapt assy 3900 TM flanged 6"	1
2	25175SP	Screw THM 8X65	12
3	16345-01SP	O-ring	2
4	BU16800	O-ring	1
5	16483	Flange ring	1
6	16482SP	Flange segment	2
7	16484	O-ring	1
8	25176	Washer	12
9	21409SP	Nut	50

11.9.2 Threaded 6", tanks adapter, TM

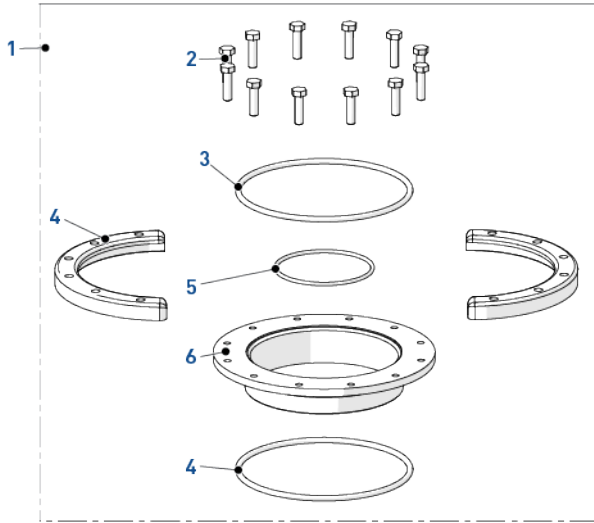

Item	Part number	Description	Packaging quantity
1	18041	Tank adapt assy 3900 TM threaded 6"	1
2	21408SP	Tank adapt screw 3900	12
3	16345-01SP	O-ring	2
4	16257SP	Flange segment	2
5	BU16800	O-ring	1
6	16255-20	Tank adapt 3900 TM threaded 6"	1

11.9.3 SM adapter

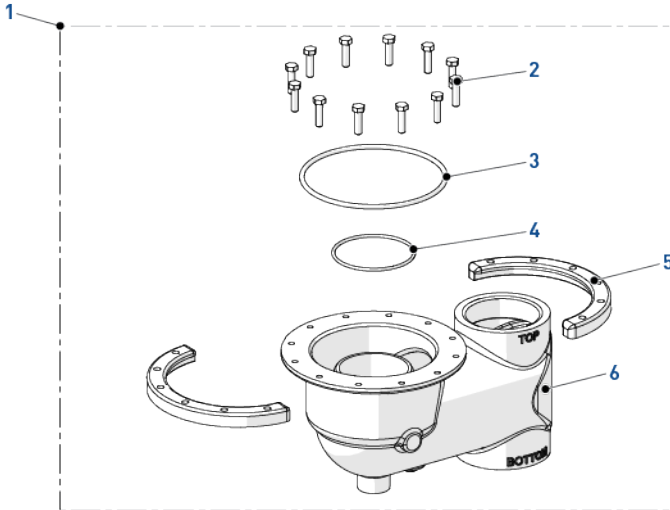

Item	Part number	Description	Packaging quantity
1	18926	Tank adapt assy 3900 SM	1
2	21408SP	Tank adapt screw 3900	12
3	16345-01SP	O-ring	2
4	BU16800	O-ring	1
5	16257SP	Flange segment	2
6	18584-22	Side mount adapter	1

11.10 Air checks list

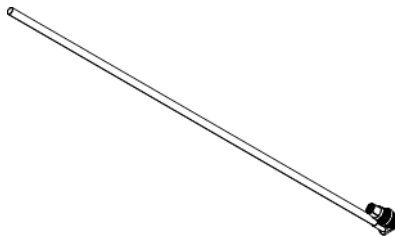

Item	Part number	Description	Packaging quantity
-	18979	Air check 900 - 1m88	5
-	BU28510	Air check 900 - 1m10	5

11.11 Meters parts list

11.11.1 Brass meters parts list

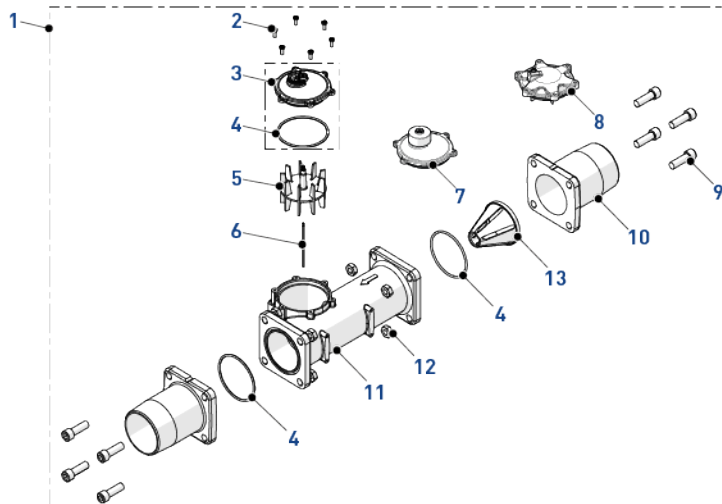

Item	Part number	Description	Packaging quantity
1	27129	Meter assy 3" electronic 3900	1
2	12112SP	Screw hex HD 10-24x1/2 (mechanical cover)	50
-	12473SP	Screw hex washer 10-24x5/8 18-8SS (electronic cover)	50
3	16400	Meter cover assy brass 240 m ³	1
4	15707SP	O-ring 560 CD meter 3"	10
5	16575	Impeller assy 3"	1
6	16279	Impeller shaft meter	1
7	16401	Meter cover assy brass 1200 m ³	1
8	14716-01	Meter cover assy electronic 3"	1
9	40118SP	Screw	10
10	16328-10	Flange adapter 3" threaded	2
11	16254	Meter body	1
12	16386SP	Nut	10
13	16280	Flow straightener 3"	1

11.11.2 Stainless steel meters parts list

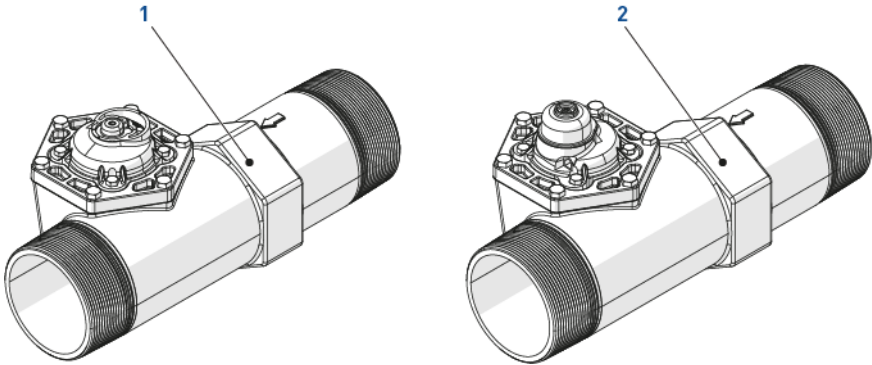

Item	Part number	Description	Packaging quantity
1	29080	Meter assy SS 3" BSP Mechanical 240 m ³ / Electronic	1
2	29081	Meter assy SS 3" BSP Mechanical 1200 m ³	1

11.12 Kit meter & Meter cables list

11.12.1 Mecanical cable meter

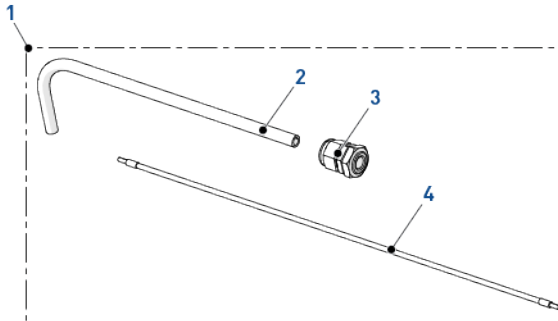

Item	Part number	Description	Packaging quantity
1	25353	Guide cable & cable assy 3900/9500	1
2	18717	Guide cable 3900	1
3	17967	Liquid tight	1
4	15513	Cable meter 444 mm	1

11.12.2 Brass kit meter & Meter cables list

Item	Part number	Description	Packaging quantity
-	28283	Kit meter assy 1" NT /NXT	1
-	28284	Kit meter assy 1.5" NT /NXT	1
-	28285	Kit meter assy 2" NT /NXT	1
-	28295	Kit meter assy 2" NT /NXT	1
-	28286	Kit meter assy 3" NT /NXT	1
-	28461-04	In-line meter 1¼" BSP plastic	1
-	19121-08	Meter cable SE/SXT 0.75 m	1
-	19121-09	Meter cable NT /NXT 2.5 m	1
-	19121-10	Meter cable NT /NXT 7.7 m	1

11.12.3 Stainless steel kit meter & Meter cables list

Item	Part number	Description	Packaging quantity
-	29096	Kit meter assy 1" stainless NXT	1
-	29097	Kit meter assy 1.5" stainless NXT	1
-	29098	Kit meter assy 2" stainless NXT	1
-	29082	Kit meter assy 3" stainless NXT	1
-	BR19791-02	Meter cable electronic 0.75 m	1
-	BR19791-04	Meter cable electronic 2.5 m	1
-	BR19791-05	Meter cable electronic 7.7 m	1

11.13 CE compliance parts list

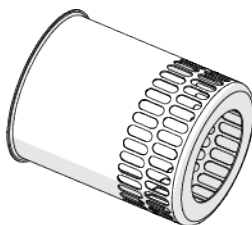

Item	Part number	Description	Packaging quantity
-	16258	Flow disperser 3" ex 16980	1

11.14 Other components list

Mixing assembly

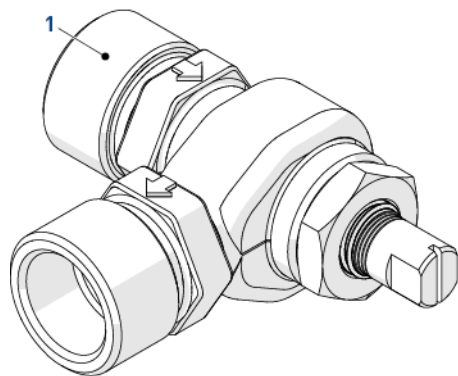

Kit 78

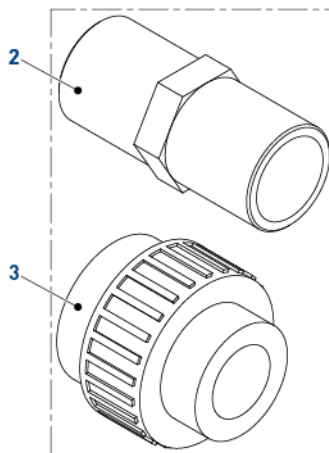

Item	Part number	Description	Packaging quantity
1	BU61564-10	Mixing assy 1" industrial	1
2	28181	PVC union female 1" BSP	2
3	16453	Pipe fitting PVC	1

12 Disposal

The device must be scrapped in accordance with directive 2012/19/EU or the environmental standards in force in the country of installation. The components included in the system must be separated and recycled in a waste recycling center that conforms with the legislation in force in the country of installation. This will help to reduce the impact on the environment, health, safety and help to promote recycling. Pentair do not collect used product for recycling. Contact your local recycling center for more information.





www.pentairaqueurope.com