



**FLECK
2850 SXT**



INSTALLER MANUAL

Table of Contents

1	Generalities	7
1.1	Scope of the documentation	7
1.2	Release management	7
1.3	Manufacturer identifier, product	7
1.4	Intended use	8
1.5	Abbreviations used	8
1.6	Norms	8
1.6.1	Applicable norms	8
1.6.2	Available certificates	9
1.7	Procedure for technical support	9
1.8	Copyright	9
1.9	Limitation of liability	10
1.10	Scan & Service application	11
2	Safety	12
2.1	Safety pictograms definition	12
2.2	Serial label location	13
2.3	Hazards	13
2.3.1	Personnel	13
2.3.2	Material	14
2.4	Hygiene and sanitization	14
2.4.1	Sanitary issues	14
2.4.2	Hygiene measures	14
3	Description	15
3.1	Technical specifications	15
3.2	Performance flow rate characteristics	17
3.3	Outline drawing	18
3.4	Components description and location	19
3.5	System regeneration cycle	20
3.5.1	Downflow regeneration cycle (5-cycles operation)	20
3.5.2	Filter cycle (3-cycles operation)	22
3.6	Configurations for softener, no by pass and filter	24
3.6.1	Downflow automatic softener	24
3.6.2	No by pass configuration	24
3.6.3	Automatic filter	25
4	System sizing	26
4.1	Recommended Injector/DLFC/BLFC-Valve configuration	26

4.2	Sizing a softener (single unit)	26
4.2.1	Parameters to be considered	26
4.2.2	Determining the required volume of resin	27
4.2.3	Resin exchange capacity and capacity of the unit	28
4.2.4	Valve configuration	29
4.2.5	Cycle time calculation	30
4.3	Salt amount definition	32
4.4	Injector flow rates	32
4.4.1	1600 injectors	33
4.4.2	1650 injectors	34
4.4.3	1700/1710 injectors	35
5	Installation	36
5.1	Warnings	36
5.2	Safety notices for installation	36
5.3	Installation environment	36
5.3.1	General	36
5.3.2	Water	37
5.3.3	Electrical	37
5.3.4	Mechanical	38
5.4	Integration constraints	38
5.5	Valve connection to piping	39
5.5.1	Top-mounted valve installation	39
5.5.2	Side-mounted valve installation	41
5.6	Block diagram and configuration example	42
5.7	Regeneration flows	44
5.8	Electrical connections	45
5.9	Bypassing	46
5.10	Drain line connection	46
5.11	Overflow line connection	47
5.12	Brine line connection	48
6	Programming	49
6.1	Display	49
6.2	Commands	50
6.3	Setting the time of the day (TD)	50
6.4	Basic programming	50
6.4.1	Basic programming mode chart	50
6.4.2	Day of override (DO)	51
6.4.3	Regeneration time (RT)	51
6.4.4	Feed water hardness (H)	51
6.4.5	Reserve capacity (RC) or (SF)	51
6.4.6	Current day of the week (CD)	51

6.5	Master programming mode	52
6.5.1	Master programming mode chart	52
6.5.2	Entering master programming mode.....	54
6.5.3	Display format mode (DF)	55
6.5.4	Regeneration flow (VT)	55
6.5.5	Regeneration control type (CT)	55
6.5.6	Number of tanks (NT).....	56
6.5.7	Tank in service (TS)	56
6.5.8	Unit capacity (C).....	56
6.5.9	Feedwater hardness (H).....	57
6.5.10	Reserve selection (RS)	57
6.5.11	Days override (DO).....	58
6.5.12	Regeneration time (RT)	58
6.5.13	Regeneration cycle step duration	59
6.5.14	Day of week (Dn, n = 1 to 7).....	59
6.5.15	Current day (CD).....	60
6.5.16	Flow meter type (FM)	60
6.5.17	Meter pulse	61
6.6	Filter programming.....	61
6.7	Diagnostic	61
6.7.1	Commands	61
6.7.2	Current flow rate (FR)	61
6.7.3	Peak flow rate (PF).....	61
6.7.4	Hours since last regeneration (HR)	62
6.7.5	Volume since last regeneration (VU)	62
6.7.6	Reserve capacity (RC)	62
6.7.7	Software version (SV)	63
6.8	Resetting the controller	63
6.8.1	Soft reset (SR)	63
6.8.2	Hard reset (HR)	63
7	Commissioning	64
7.1	Water filling, draining and waterproofness inspection	64
7.2	Sanitization	65
7.2.1	Disinfection of water softeners.....	65
7.2.2	Sodium or calcium hypochlorite	65
7.2.3	Electro chlorination.....	66
8	Operation.....	67
8.1	Display	67
8.1.1	Display during operation.....	67
8.1.2	Display during regeneration	67
8.2	Recommendations	68
8.3	Manual regeneration	68
8.3.1	Manual delayed regeneration	68
8.3.2	Immediate regeneration	68
8.3.3	To advance regeneration cycles	68

8.4	Operation during a power failure	69
9	Maintenance	70
9.1	General system inspection	70
9.1.1	Water quality	70
9.1.2	Mechanical Checks	70
9.1.3	Regeneration test	71
9.2	Recommended maintenance plan	72
9.2.1	Valve used for softening	72
9.2.2	Valve used for filtration	74
9.3	Recommendations	75
9.3.1	Use original spare parts	75
9.3.2	Use original approved lubricants	75
9.3.3	Maintenance instructions	75
9.4	Cleaning and maintenance	75
9.4.1	First steps	75
9.4.2	Power head and/or motor replacement	76
9.4.3	Controller replacement	77
9.4.4	Piston and/or seal and spacer kit disassembly/replacement	78
9.4.5	Micro-switches replacement	80
9.4.6	Cams replacement	81
9.4.7	Injector cleaning	82
9.4.8	BLFC cleaning	83
9.4.9	DLFC cleaning	84
9.4.10	Valve on tank assembly	85
10	Troubleshooting	86
10.1	Error detection	89
10.1.1	Motor stall/cam sense error	89
10.1.2	Motor run-ON error/cycle sense error	90
10.1.3	Regeneration failure	90
10.1.4	Memory error	91
11	Spare parts and options	92
11.1	Valve parts list	92
11.2	Power head parts list	93
11.3	Injector parts list	94
11.3.1	1600/1650 injector parts list	94
11.3.2	1700/1710 injector parts list	96
11.4	Brine valve parts list	97
11.5	Safety brine valves list	99
11.6	Safety brine valves parts list	99
11.7	Distribution systems parts list	100
11.8	Air checks list	101
11.9	Meters parts list	101

11.9.1	Brass meters parts list	101
11.9.2	Stainless steel meters parts list.....	102
11.10	Kit meter & Meter cables list.....	102
11.10.1	Brass kit meter & Meter cables list.....	102
11.10.2	Stainless steel kit meter & Meter cables list	103
11.11	CE compliance parts list	103
11.12	Other components list.....	104
12	Disposal.....	105

1 Generalities

1.1 Scope of the documentation

The documentation provides the necessary information for appropriate use of the product. It informs the user to ensure efficient execution of the installation, operation or maintenance procedures.

The content of this document is based on the information available at the time of publication. The original version of the document was written in English.

For safety and environmental protection reasons, the safety instructions given in this documentation must be strictly followed.

This manual is a reference and will not include every system installation situation. The person installing this equipment should have:

- training in the Fleck series, SXT controllers and water softener installation;
- knowledge of water conditioning and how to determine proper controller settings;
- basic plumbing skills.

This document is available in other languages on <https://www.pentairaquaeurope.com/product-finder/product-type/control-valves>.

1.2 Release management

Revision	Date	Authors	Description
A	26.04.2018	BRY/GJA	First edition.
B	12.11.2019	BRY	Corrections.

1.3 Manufacturer identifier, product

Manufacturer: Pentair International LLC
Avenue de Sevelin 18
1004 Lausanne
Switzerland

Product: Fleck 2850 SXT

1.4 Intended use

The device is intended for industry environment use only and it is purpose-built for water treatment.

1.5 Abbreviations used

Assy	Assembly
BLFC	Brine Line Flow Controller
BV	Brine Valve
CW	Cold Water
DF	Down Flow
Distr	Distribution
DLFC	Drain Line Flow Controller
HW	Hot Water
Inj	Injector
N/A	Not Available
NBP	No By Pass
PN	Part Number
Regen	Regeneration
S&S	Seals & Spacers
SBV	Safety Brine Valve
STD	Standard
SM	Side Mounted
Sys	System
TC	Time Clock
TM	Top Mounted
UF	Up Flow
VB	Valve Body

1.6 Norms

1.6.1 Applicable norms

Comply with the following guidelines:

- 2006/42/EC: Machinery Directive;
- 2014/35/UE: Low Voltage Directive;
- 2014/30/UE: Electromagnetic compatibility;
- 2011/65/UE: Restriction of use of certain hazardous substances in electrical and electronic equipment (RoHS);
- UNI EN ISO9001.

Meets the following technical standards:

- EN 55014-1;
- EN 55014-2;
- EN 61000-6-1;
- EN 61000-6-2;
- EN 61000-6-3;
- EN 61000-6-4;
- EN 61010-1;
- EN 61000-3-2;
- EN 61000-3-3.

1.6.2 Available certificates

- CE;
 - DM174;
 - ACS.
- Please find beside the certifications for some of our product families. Please note that this list is not an exhaustive list of all our certifications. In case of need for more information please contact us.



1.7 Procedure for technical support

Procedure to follow for any technical support request:

1. Collect the required information for a technical assistance request.
 - ⇒ Product identification [see Serial label location [▶Page 13] and Recommendations [▶Page 75]];
 - ⇒ Description of the device problem.
2. Please refer to the Troubleshooting [▶Page 86]. If the problem persists contact your supplier.

1.8 Copyright

© 2019 Pentair International Sàrl. All rights reserved.

1.9 Limitation of liability

Pentair Quality System EMEA products benefit, under specific conditions, from a manufacturer warranty that may be invoked by Pentair's direct customers. Users should contact the vendor of this product for applicable conditions and in case of a potential warranty claim.

Any warranty provided by Pentair regarding the product will become invalid in case of:



- improper installation, improper programming, improper use, improper operation and/or maintenance leading to any kind of product damages;
- improper or unauthorized intervention on the controller or components;
- incorrect, improper or wrong connection/assembly of systems or products with this product and vice versa;
- use of a non-compatible lubricant, grease or chemicals of any type and not listed by the manufacturer as compatible for the product;
- failure due to wrong configuration and/or sizing.

Pentair accepts no liability for equipment installed by the user upstream or downstream of Pentair products, as well as for process/production processes which are installed and connected around or even related to the installation. Disturbances, failures, direct or indirect damages that are caused by such equipment or processes are also excluded from the warranty. Pentair shall not accept any liability for any loss or damage to profits, revenues, use, production, or contracts, or for any indirect, special or consequential loss or damage whatsoever. Please refer to the Pentair List Price for more information about terms and conditions applicable to this product.

1.10 Scan & Service application

Scan & Service mobile application is the ideal support for the maintenance person in his daily business. A simple scan of an identification (ID) label (1) present on the valve with a smartphone gives an instantaneous access to all updated information related to the product, such as:

- valve's and tanks detailed configuration;
- manuals;
- spare parts lists;
- troubleshooting recommendations;
- multi-lingual videos, detailing how to best service a part;
- informations about new products, latest technologies, novelties about the Blue Network program, etc.

1. Download the application "Scan & Service" from  or  in a smartphone (4).
2. Open the application "Scan & Service".
3. Scan the bleam (3) stuck on the valve (2).
4. Navigate to find information.

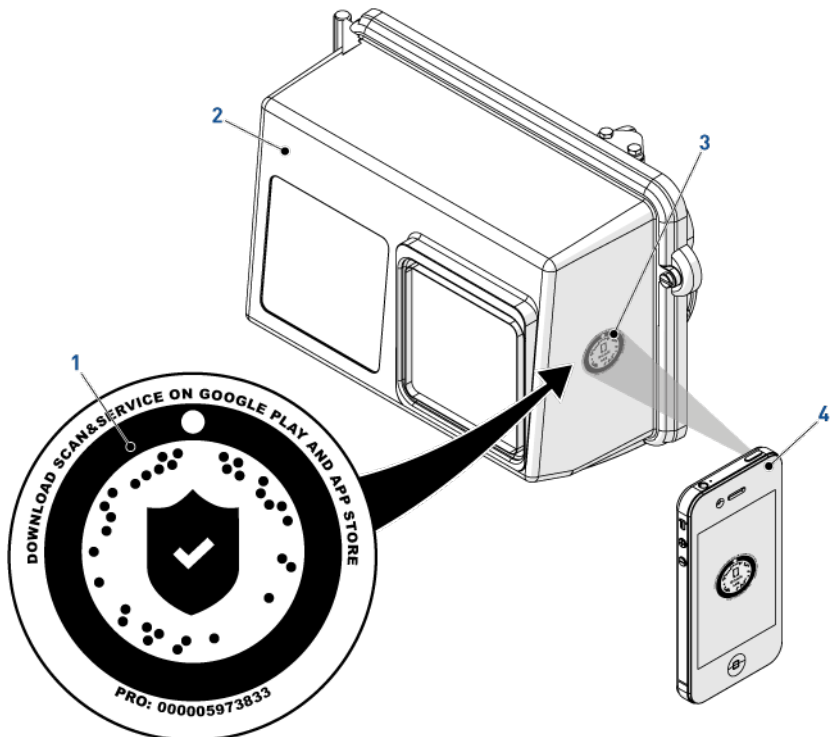

2 Safety

2.1 Safety pictograms definition

DANGER



This combination of symbol and keyword indicates an imminently hazardous situation that will result in serious or fatal injury if not avoided.

WARNING



This combination of symbol and keyword indicates a potentially hazardous situation that can result in serious or fatal injury if not avoided.

CAUTION



This combination of symbol and keyword indicates a potentially hazardous situation that can result in minimal or minor injury if not avoided.

Caution - material



This combination of symbol and keyword indicates a potentially hazardous situation that can result in material damage if not avoided.

Prohibition



Mandatory advice to follow.

Mandatory



Applicable guideline, measure.

Info



Informative comment.

2.2 Serial label location

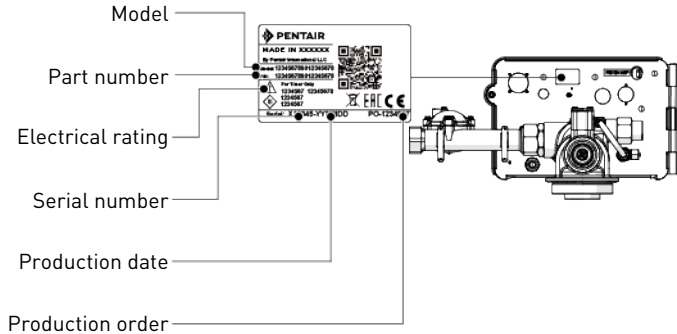

Mandatory



Ensure that the serial label and the safety labels on the device are completely legible and clean !

If necessary, replace them with new labels in the same positions.

2.3 Hazards

All the safety and protection instructions contained in this document must be observed in order to avoid temporary or permanent injury, damage to property or environmental pollution.

At the same time, any other legal regulations, accident prevention and environmental protection measures, as well as any recognized technical regulations relating to appropriate and risk-free methods of working which apply in the country and place of use of the device must be adhered to.

Any non-observation of the safety and protection rules, as well as any existing legal and technical regulations, will result in a risk of temporary or permanent injury, damage to property or environmental pollution.

2.3.1 Personnel



CAUTION



Risk of injury due to improper handling!

Only qualified and professional personnel, based on their training, experience and instruction as well as their knowledge of the regulations, safety rules and operations performed, are authorized to carry out necessary work.

2.3.2 Material

The following points must be observed to ensure proper operation of the system and the safety of user:

- be careful of high voltages present on the transformer (100 – 240 V);
- do not put your fingers in the system (risk of injuries with moving parts and shock due to electric voltage).

2.4 Hygiene and sanitization

2.4.1 Sanitary issues

Preliminary checks and storage

- Check the integrity of the packaging. Check that there is no damage and no signs of contact with liquid to make sure that no external contamination occurred;
- the packaging has a protective function and must be removed just before installation. For transportation and storage, appropriate measures should be adopted to prevent the contamination of materials or the objects themselves.

Assembly

- Assemble only with components which are in accordance with drinking water standards;
- after installation and before use, perform one or more manual regenerations in order to clean the media bed. During such operations, do not use the water for human consumption. Perform a disinfection of the system in the case of installations for treatment of drinking water for human use.

Info



This operation must be repeated in the case of ordinary and extraordinary maintenance. It should also be repeated whenever the system remains idle for a significant time.

Valid only for Italy

In case of equipment used in accordance with the DM25, apply all the signs and obligations arising from the DM25.

2.4.2 Hygiene measures

Disinfection

- The materials used for the construction of our products meet the standards for use with potable water; the manufacturing processes are also geared to preserving these criteria. However, the process of production, distribution, assembly and installation, may create conditions of bacterial proliferation, which may lead to odor problems and water contamination;
- it is therefore strongly recommended to sanitize the products. See Sanitization [▶ Page 65] ;
- maximum cleanliness is recommended during the assembly and installation;
- for disinfection, use Sodium or Calcium Hypochlorite and perform a manual regeneration.

3 Description

3.1 Technical specifications

Design specifications/ratings

Valve body	Brass
Rubber components	EP or EPDM
Weight (valve with controller)	4.6 kg (max)
Recommended operating pressure	1.8 - 8.6 bar
Maximum inlet pressure	8.6 bar
Hydrostatic test pressure	20 bar
Water temperature std	1 - 43°C
Water temperature for HW volumetric	1 - 65°C
Water temperature for HW time clock	1 - 82°C
Ambient temperature	5 -40°C
Regeneration flow	DF
Bypass of raw water during regeneration:	
Standard	Yes
NBP version	No

Flow rates (3.5 bar inlet - valve only - top mount)

Continuous service flow ($\Delta p = 1$ bar)	11.6 m ³ /h
Peak service flow ($\Delta p = 1.8$ bar)	15.0 m ³ /h
Cv*	13.2 gpm
Kv*	11.4 m ³ /h
Maximum backwash flow ($\Delta p = 1.8$ bar)	11.1 m ³ /h

*Cv: Flow rate in gpm across the valve at a pressure drop of 1 psi at 60°F.

*Kv: Flow rate in m³/h across the valve at a pressure drop of 1 bar at 16°C.

Valve connections

Tank top mounted adapter	4" – 8 UN
Inlet/Outlet	1½" BSP female
Riser tube	50 mm [DN40]
Drain line	1" NPT
Brine line (1600/1650)	⅜"
Brine line (1700/1710)	½"

Electrical

Transformer input voltage	100 to 240 VAC
Input supply frequency	50 to 60 Hz
Transformer output voltage	24 VAC, 60 VA
Controller input voltage	24 VAC
Motor input voltage	24 VAC
Controller max. power consumption	35 W
Controller protection rating	IP 22
Valve protection rating	IP 44
Power supply	230 VAC, 50/60 Hz, 60 VA, Class II
Transient overvoltages	within the limits of category II
Pollution Degree	3

Temporary overvoltages must be limited in duration and in frequency.

Environmental conditions

- Indoor use only;
- temperature from 5°C to 40°C;
- maximum relative humidity 80% for temperatures up to 31°C decreasing linearly to 50% relative humidity at 40°C;
- mains supply voltage fluctuations up to $\pm 10\%$ of the nominal voltage.

3.2 Performance flow rate characteristics

The graph shows the pressure drop created by the valve itself at different flow rates. It allows predetermining the maximum flow rate going through the valve depending on the system settings (inlet pressure etc). It also allows to determine the valve pressure drop at a given flow rate, and therefore to evaluate the system pressure drop vs flow rate.

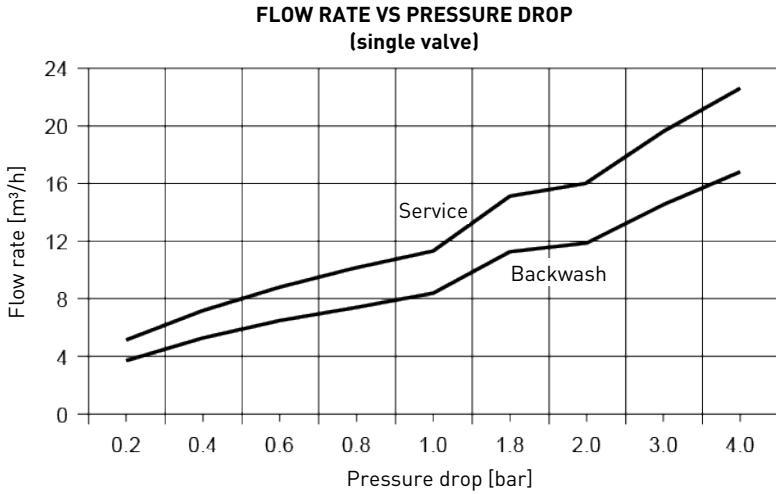

3.3 Outline drawing

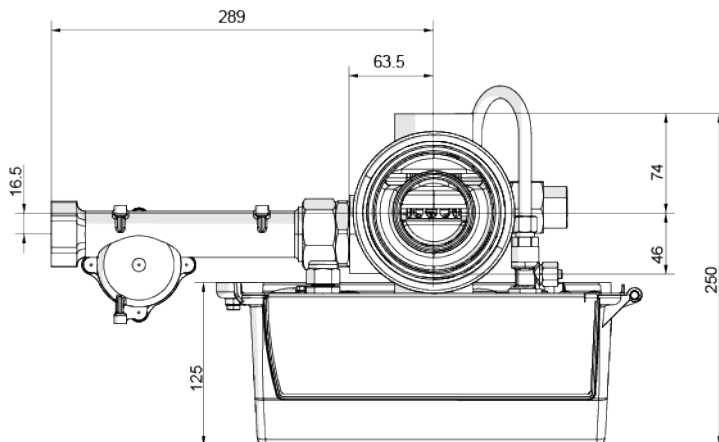
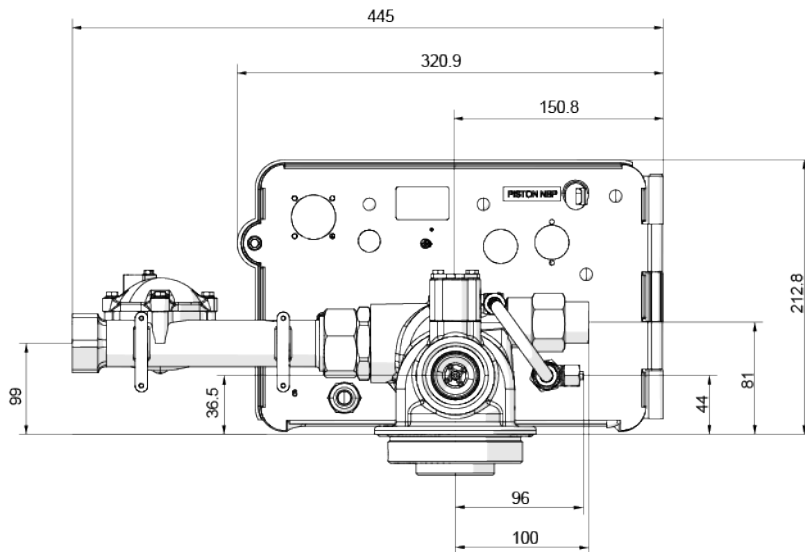

3.4 Components description and location

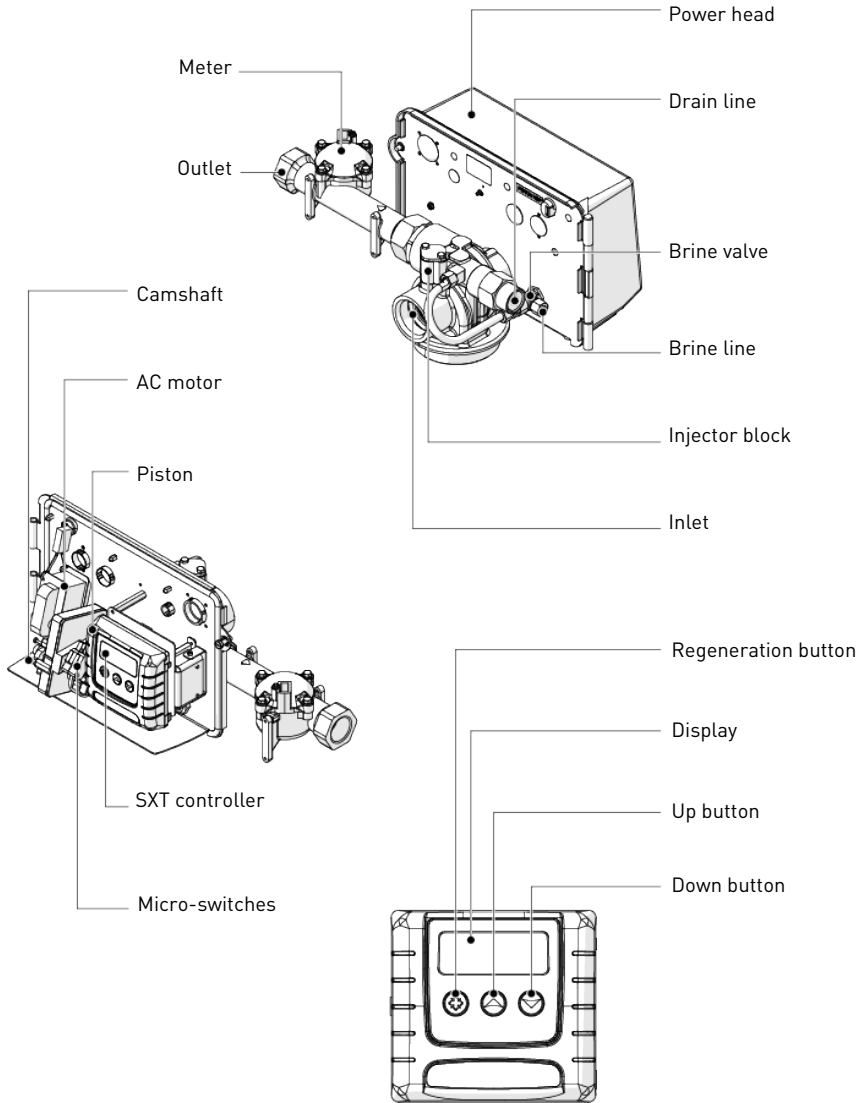

3.5 System regeneration cycle

Info



This valve allows to do filtration and down flow regenerations.

3.5.1 Downflow regeneration cycle (5-cycles operation)

Service — normal use

Untreated water is directed down through the resin bed and up through the riser tube. The hardness ions attach themselves to the resin and are removed from the raw water being exchanged on the resin beads by sodium ions. The water is conditioned as it passes through the resin bed.

Backwash — cycle C1

The flow of water is reversed by the valve and directed down the riser tube and up through the resin bed. During the backwash cycle, the bed is expanded and debris is flushed to the drain, while the media bed is remixed.

Brine draw & slow rinse — cycles C2

The valve directs water through the brine injector and brine is drawn from the brine tank. The brine is then directed down through the resin bed and up through the riser tube to the drain. The hardness ions on the resin beads are replaced by sodium ions and are sent to the drain. The resin is regenerated during the brine cycle. When the air check valve closes brine drawing finishes, and then the slow rinse phase starts.

Rapid rinse — cycle C3

The valve directs water down through the resin bed and up through the riser tube to the drain. Any residual brine is rinsed from the resin bed, while the media bed is re-compacted.

Brine tank refill — cycle C4

Water is directed to the brine tank, at a rate controlled by the refill controller [BLFC], to create brine for the next regeneration. During brine refill, treated water is already available at the valve outlet.

Info



For illustration purpose only. Always verify inlet and outlet marking on the valve.

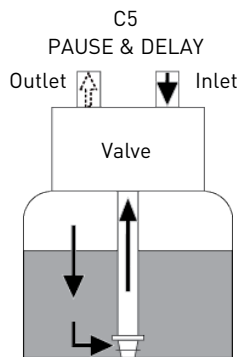
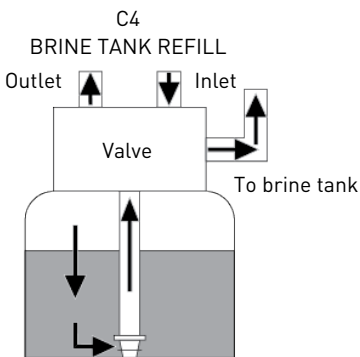
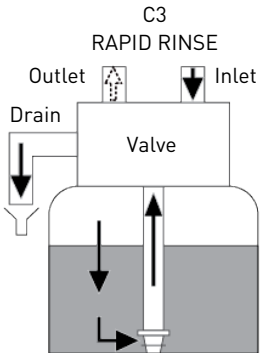
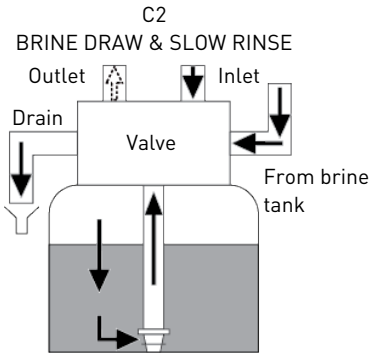
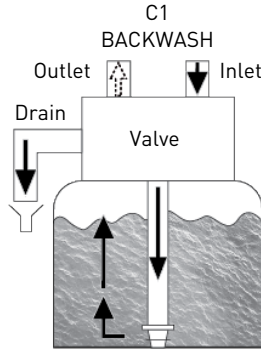
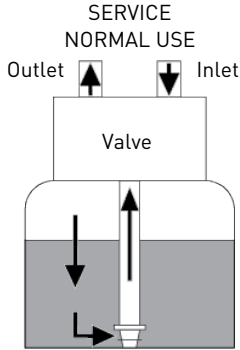

☞ Untreated water, with WBP piston only

3.5.2 Filter cycle (3-cycles operation)

Service — normal use

Untreated water is directed down through the filter media and up through the riser tube. The impurities are retained by the media. The water is filtered as it passes through the media.

Backwash — cycle C1

The flow of water is reversed by the valve and directed down through the riser tube and up through the filter media. During the backwash cycle, the filter bed is expanded and debris is flushed to the drain, while the media bed is remixed.

Rapid rinse — cycle C2

The valve directs water down through the filter media and up through the riser tube to the drain. The media bed is getting re-compacted.

Info



For illustration purpose only. Always verify inlet and outlet marking on the valve.

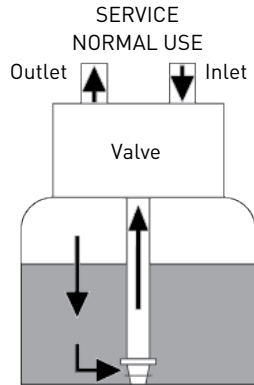
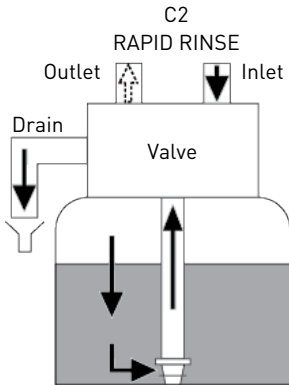
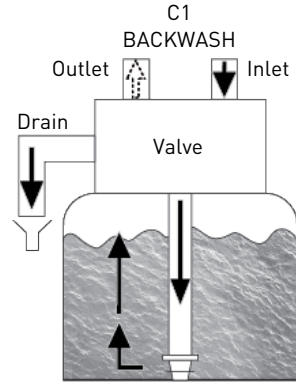
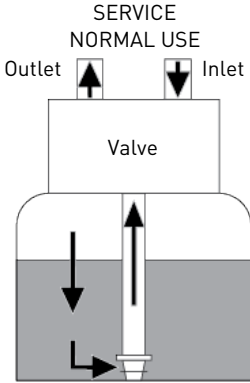

Untreated water, with WBP piston only

3.6 Configurations for softener, no by pass and filter

3.6.1 Downflow automatic softener

The valve is mounted with the SXT power head 2510/2750/2850/2910, part number VCPHINDUS1 and a 1600 or 1700/1710 injector assembly, part numbers 24199-X, 24173-X or 24555-X for HW.

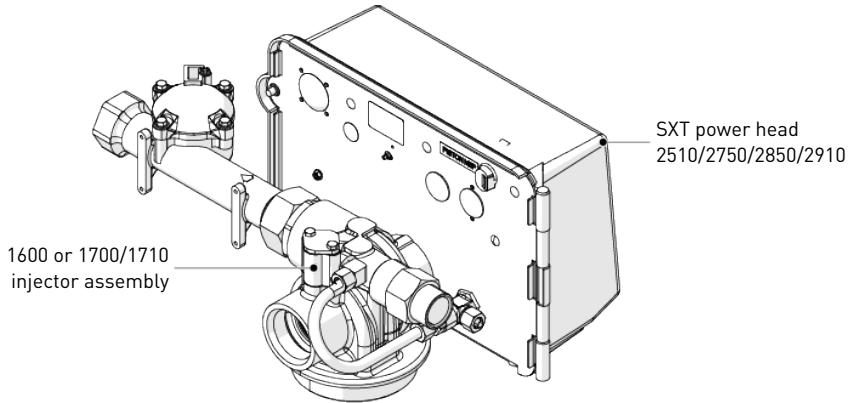

3.6.2 No by pass configuration

The valve is mounted with the SXT power head 2510/2750/2850/2910, part number VCPHINDUS1, a valve body assembly 2850 NBP, part number BU28514-02, a spacer, part number BR19339 and a 1600 or 1700/1710 injector assembly, part numbers 24199-X, 24173-X or 24555-X for HW.

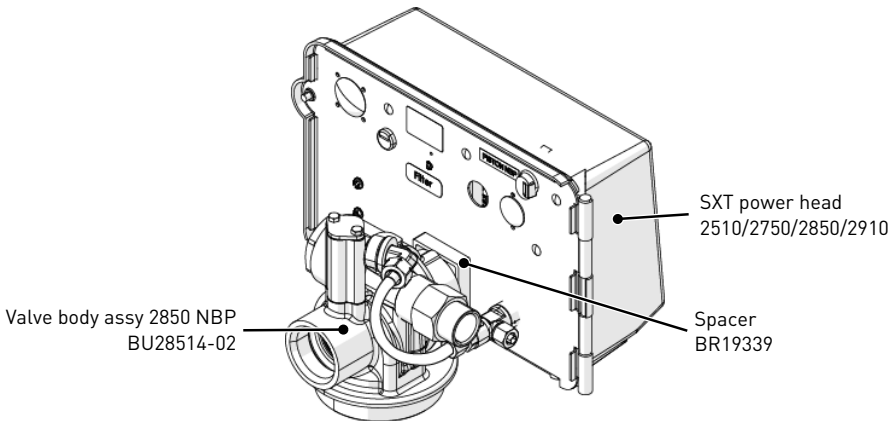

3.6.3 Automatic filter

The valve is mounted with the SXT power head 2510/2750/2850/2910, part number VCPHINDUS1 and an injector flat cover, part number 11893SP.

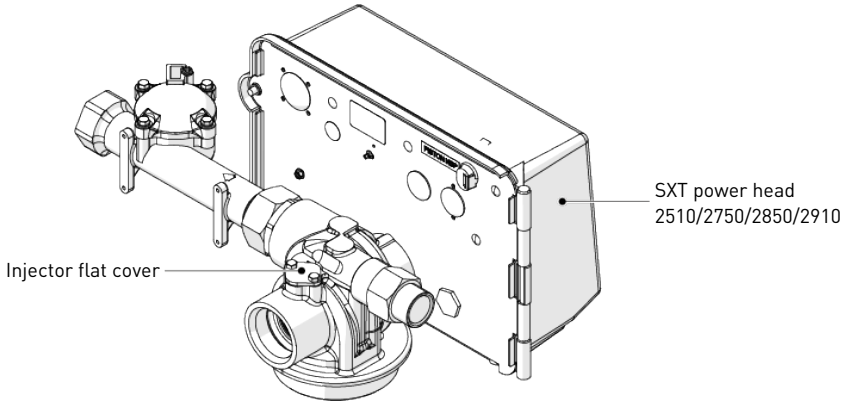

4 System sizing

4.1 Recommended Injector/DLFC/BLFC-Valve configuration

Brine syst.	Tank Diameter	Resin volume L	Injector				DLFC	BLFC	
	[in]		DF	Color	UF	Color	[gpm]	DF [gpm]	UF [gpm]
2850/ 1600	10	35 – 42	1	White	N/A	N/A	2.4	0.50	N/A
	12	43 – 56	2	Blue			3.5		
	14	57 – 85	3	Yellow			5.0	1.0	
2850/ 1700	16	83 – 113	3C	Green			7.0	1.2	
	21	114 – 198	4C				10.0	2.0	
	24	199 - 283	5C	White			15.0	4.0	
	30	284 - 425					25.0		

4.2 Sizing a softener (single unit)

4.2.1 Parameters to be considered

Whenever installing a softener, it is preferable to have full water analysis to ensure the inlet water content will not affect the resin bed.

Tip



Please consult your resin manufacturer specification !

To ensure that no additional pretreatment prior to softening is required.

The below sizing method can be applied for both residential and industrial softeners.

The sizing of a softener must be based upon certain parameters:

- inlet water hardness;
- peak flow rate and nominal flow rate;
- service velocity;
- salt dosage.

The softening and regeneration reactions are driven under certain conditions. To allow these reactions to take place, make sure that the velocity is convenient during the different phases for proper ion exchange. This velocity is given in the resin manufacturer specifications sheet.

Depending on the inlet water hardness, the service velocity for standard softening must be between:

Service velocity [bed volume per hour]	Inlet water hardness [mg/l as CaCO ₃]	°f °TH	°dH
8 - 40	<350	<35	<19.6
8 - 30	350 to 450	35 - 45	19.6 - 25.2
8 - 20	>450	>45	>25.2

Caution - material

Risk of leakage due to unrespected service velocity !

Failure to respect the service velocity will lead to hardness leakage or even total softener inefficiency.

Note that the water supply piping size may also be useful when estimating the nominal flow rate, since the size of the piping allows a maximum flow rate to pass. Assuming the maximum velocity of water in pipes is about 3 m/s, a good estimation for most common pressure [3 bar] and temperature [16°C] is:

Piping size (internal diameter)		Max. flow rate
[in]	[mm]	[m ³ /h at 3 m/s]
0.5	12	1.22
0.75	20	3.39
1	25	5.73
1.25	32	8.69
1.5	40	13.57
2.0	50	21.20
2.5	63	34.2
3.0	75	49.2

4.2.2 Determining the required volume of resin

When sizing a softener, make sure that the volume of resin in the tank (bed volume) will be sufficient so that even when the peak flow rate is reached, the velocity is still between the above values depending on the hardness. When sizing a softener, always choose the resin volume and tank size based on the peak flow rate but not on the nominal flow rate.

Caution - material

Risk of leakage due to wrong sizing !

Sizing on the nominal flow rate without taking the peak flow rate into account would result in choosing smaller tank size and resin volume, and may lead in severe hardness leakage during the service cycle when the peak flow is reached.

The maximum softened water flow rate that a softener can produce is given by the following formula:

$$Q_{\text{service max}} = F_{\text{service}} \times BV$$

with:

$Q_{\text{service max}}$: service flow rate [m³/h]

F_{service} : service velocity [BV/h]

BV: bed volume of resin [m³]

Knowing this required volume of resin, it is possible now to determine the needed tank. Note that at least a third of the total volume of the tank must be kept as free space so that the bed expansion during backwash is sufficient to ensure correct cleaning of the resin.

4.2.3 Resin exchange capacity and capacity of the unit

The resin exchange capacity and capacity of the unit are two different things that should not be confused. The resin exchange capacity is the amount of Ca^{2+} and Mg^{2+} that can be retained by 1 litre of resin, which will depend on the resin type and salt dosage, whereas the capacity of the unit is the capacity of the system, which will depend on the volume of resin and resin exchange capacity.

Knowing the required volume of resin, it is possible to determine the exchange capacity of the unit. The capacity of the unit can be expressed in different ways:

- the mass capacity, which corresponds to the weight in equivalent CaCO_3 that can be fixed on the resin, expressed in kg as CaCO_3 ;
- the volume capacity, which represents the maximum amount of water that can be treated between 2 regenerations. This last capacity takes into account the hardness of the water to be treated and is expressed in m^3 or litre;
- the combined capacity, which represents the volume of water that could be treated between 2 regenerations if the inlet hardness is 1 °f or °dH. This capacity is expressed in °f. m^3 or °dH. m^3 .

The resin exchange capacity will depend on the amount of salt to be injected into the resin bed during the regeneration. This amount of salt is given in grams per litre of resin. The next table is showing the resin exchange capacity in function of the amount of salt for a system with standard efficiency regeneration.

Resin exchange capacity as a function of the salt dosage:

Salt amount [g/L _{resin}]	Corresponding resin exchange capacity in [g/L _{resin}] as CaCO_3	°f. m^3 [per L _{resin}]	°dH. m^3 [per L _{resin}]
50	29.9	2.99	1.67
60	34	3.4	1.9
70	37.5	3.75	2.09
80	40.6	4.06	2.27
90	43.4	4.34	2.42
100	45.9	4.59	2.56
110	48.2	4.82	2.69
120	50.2	5.02	2.8
130	52.1	5.21	2.91
140	53.8	5.38	3.01
150	55.5	5.55	3.1
170	58.5	5.85	3.27
200	62.7	6.27	3.5
230	66.9	6.69	3.74
260	71	7.1	3.97
290	75.3	7.53	4.21

To calculate the system mass capacity:

$$M_{\text{capacity}} = V_{\text{resin}} \times C_{\text{resin ex}}$$

with:

 M_{capacity} : system mass capacity [g as CaCO_3]

 V_{resin} : volume of resin [L]

 $C_{\text{resin ex}}$: resin exchange capacity [g/L_{resin} as CaCO_3]

To calculate the system combined capacity:

$$C_{\text{capacity}} = V_{\text{resin}} \times C_{\text{cor resin ex}}$$

with:

 C_{capacity} : system combined capacity [$^\circ\text{f.m}^3$ or $^\circ\text{dH.m}^3$]

 V_{resin} : volume of resin [L]

 $C_{\text{cor resin ex}}$: corresponding resin exchange capacity [$^\circ\text{f.m}^3/\text{l}$ or $^\circ\text{dH.m}^3/\text{l}$]

To calculate the system volume capacity:

$$V_{\text{capacity}} = M_{\text{capacity}} / TH_{\text{inlet}}$$

with:

 V_{capacity} : system volume capacity [m^3]

Or

 M_{capacity} : system mass capacity [g as CaCO_3]

 C_{capacity} : system combined capacity [$^\circ\text{f.m}^3$ or $^\circ\text{dH.m}^3$]

$$V_{\text{capacity}} = C_{\text{capacity}} / TH_{\text{inlet}}$$

 TH_{inlet} : inlet water hardness [mg/L as CaCO_3 or $^\circ\text{f}$ or $^\circ\text{dH}$]

Mandatory

If a mixing device is set on the valve before meter, use $TH = TH_{\text{INLET}} - TH_{\text{OUTLET}}$!

Having determined the previous capacity allows the operator to know the service cycle duration.

4.2.4 Valve configuration

Knowing the volume of resin, tank size and specifications of the resin, it is possible to determine the required valve configuration. The resin specification will give the backwash velocity, as well as the brine draw and slow rinse velocity that must be respected in order to ensure a proper regeneration of the unit. From this data, determine the required backwash flow rate as well as the brine draw and slow rinse flow rate. In most cases, the fast rinse flow rate will be the same as the backwash flow rate, however for certain valve types the fast rinse flow rate will be the same as the service flow rate.

To determine the backwash flow rate:

$$Q_{\text{backwash}} = F_{\text{S}_{\text{backwash}}} \times S$$

with:

 Q_{backwash} : backwash flow rate [m^3/h]

 $F_{\text{S}_{\text{backwash}}}$: backwash velocity [m/h]

 S : Tank cross section area [m^2]

The DLFC installed on the valve has to limit the backwash flow rate to the above calculated flow rate.

To determine the injector size:

The velocities to be respected for brine draw and slow rinse are given on the resin manufacturer specifications. Generally speaking, the injector has to allow a flow rate of about 4BV / h (corresponding to the flow rate of brine being drawn added to the flow rate of raw water passing through the injector nozzle to create the suction effect).

$$Q_{inj} = 4 \times BV / h$$

with:

Q_{inj} : total flow rate passing through the injector [L/h]

BV: bed volume of resin [L]

Info



This value does not correspond to the brine draw flow rate but to the total flow rate passing through the injector.

Refer to the injector diagrams at the inlet pressure in order to check if the injector will give a correct flow rate.

See chapters Salt amount definition [► Page 32] and Injector flow rates [► Page 32].

4.2.5 Cycle time calculation

From this point, the volume of resin, the tank size, the capacity of the softener and the valve configuration are determined. Next step is to calculate the regeneration cycle duration, which depends on the valve configuration and once again on the resin specifications.

Info



Preprogrammed cycle times are only factory default programming that need to be adjusted to fit the system requirements.

For cycle time calculation the valve configuration must be known, which depends on:

- the tank size;
- the resin specifications for the velocity for backwashing the resin bed;
- the velocity of water for brine draw, slow rinse and fast rinse.

Further information needed for cycle time calculation are:

- the resin volume previously determined;
- the salt amount used per regeneration;
- the volume of water to use for backwash, brine draw, slow rinse and fast rinse.

To calculate the backwash duration:

$$T_{\text{backwash}} = (N_{\text{BVbw}} \times \text{BV}) / Q_{\text{DLFC}}$$

with:

T_{backwash} : backwash duration [min]

N_{BVbw} : number of bed volume for backwash

BV: bed volume [L]

Q_{DLFC} : drain line flow controller size [L/min]

Info



The typical value of the volume of water to be used for backwash is between 1.5 and 4 times the bed volume, depending on the inlet water quality.

To calculate the brine draw duration:

Knowing the injector draw flow rate at the working pressure:

$$T_{\text{brine draw}} = V_{\text{brine}} / Q_{\text{draw}}$$

with:

$T_{\text{brine draw}}$: brine draw duration [min]

V_{brine} : brine volume to be drawn [L], see Refill calculation [▶ Page 32].

Q_{draw} : injection draw flow rate [L/min]

Tip



Multiply the amount of salt in kg by 3 to get a approximation of the brine volume to draw !

To calculate slow rinse duration:

The volume of water to be used for slow rinse is given in the resin manufacturers specifications. Generally speaking, it is advised that between 2 and 4 BV of water is used to perform the slow rinse after brine draw. The slow rinse cycle allows brine to be pushed slowly through the resin bed, allowing the resin to be in contact with brine for sufficient time and therefore to be regenerated.

Refer to the injector curve at the common working pressure to determine the slow rinse duration.

$$T_{\text{slow rinse}} = (N_{\text{BVsr}} \times \text{BV}) / Q_{\text{SR}}$$

with:

$T_{\text{slow rinse}}$: slow rinse duration [min]

N_{BVsr} : number of bed volume for slow rinse

BV: bed volume [L]

Q_{SR} : injector slow rinse flow rate [L/min]

To calculate fast rinse duration:

The fast rinse is aimed at eliminating an excess of salt in the resin bed and also recompacting the resin in the tank.

Depending on the valve type, the fast rinse flow rate is controlled by the DLFC or it has about the same flow rate as in service. The fast rinse velocity can be the same as the service velocity, and the volume of water to be used for the fast rinse is generally between 1 and 10 BV depending on the salt dosage.

$$T_{\text{fast rinse}} = (N_{\text{BVfr}} \times \text{BV}) / Q_{\text{DLFC}}$$

with:

$T_{\text{fast rinse}}$: fast rinse duration [min]

N_{BVfr} : number of bed volume for fast rinse

BV: bed volume [L]

Q_{DLFC} : drain line flow controller size [L/min]

To calculate the refill duration:

The refill flow rate is controlled by the refill controller (BLFC). The relation between the BLFC size, the tank size and the resin volume is given in the valve specifications.

To calculate the refill duration:

$$T_{\text{refill}} = V_{\text{WB}} / Q_{\text{BLFC}}$$

with:

T_{refill} : refill duration [min]

V_{WB} : Volume of water to be refill to prepare the brine [L]

Q_{BLFC} : BLFC size [L/min]

$$V_{\text{WB}} = D_{\text{Salt}} \times \text{BV} / S_{\text{sol}}$$

with:

V_{WB} : Volume of water to be refill to prepare the brine [L]

D_{Salt} : Salt dosage per litre of resin [g/L]

BV: Bed volume [L]

S_{sol} : 360g/L - Solubility of salt per litre of water

Tip



When calculating the time required to draw the brine, take into account that the volume of brine [Vbrine] will be 1.125 bigger than the volume of water refilled !

4.3 Salt amount definition

The salt settings are controlled through the controller programming. See Resin exchange capacity and capacity of the unit [▶ Page 28].

4.4 Injector flow rates

The following tables and graphics represent the injectors flow rate as a function of the inlet pressure for the different injector sizes.

4.4.1 1600 injectors

INJECTOR 1

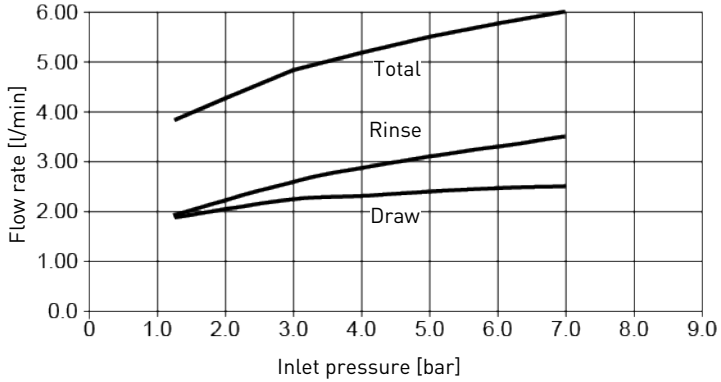

INJECTOR 2

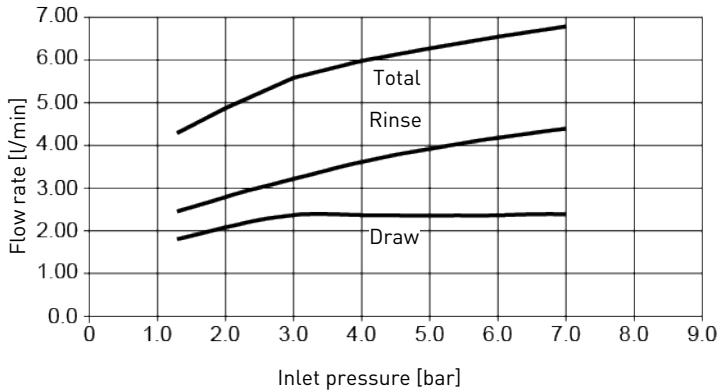

INJECTOR 3

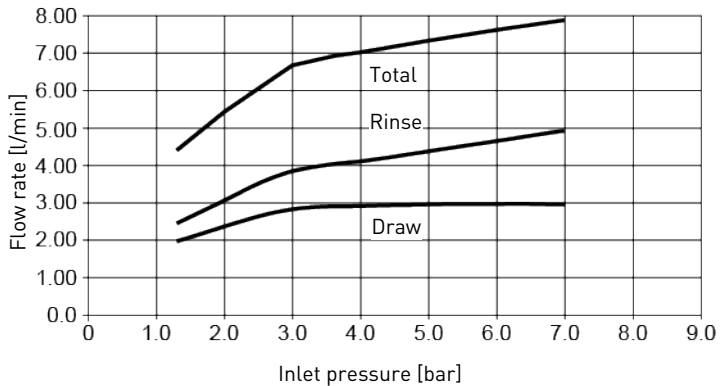

4.4.2 1650 injectors

INJECTOR 1

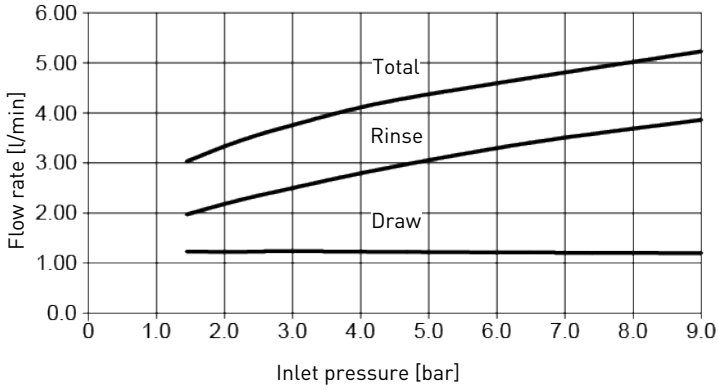

INJECTOR 2

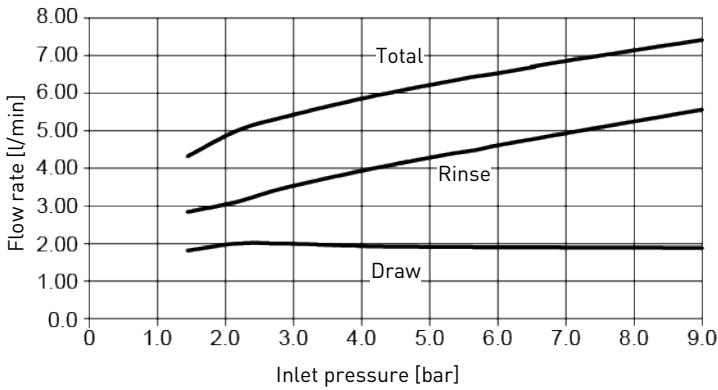

INJECTOR 3

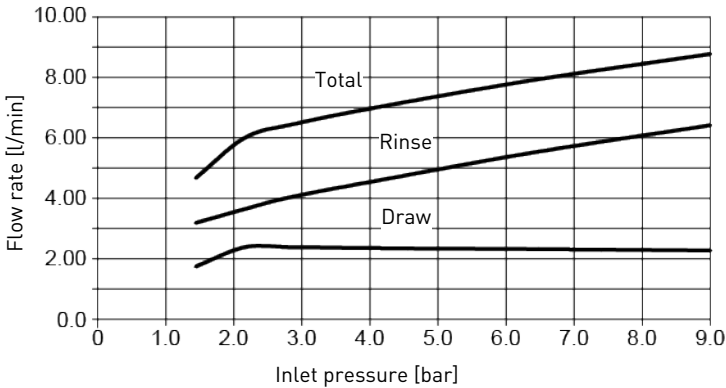

4.4.3 1700/1710 injectors

INJECTOR 3C

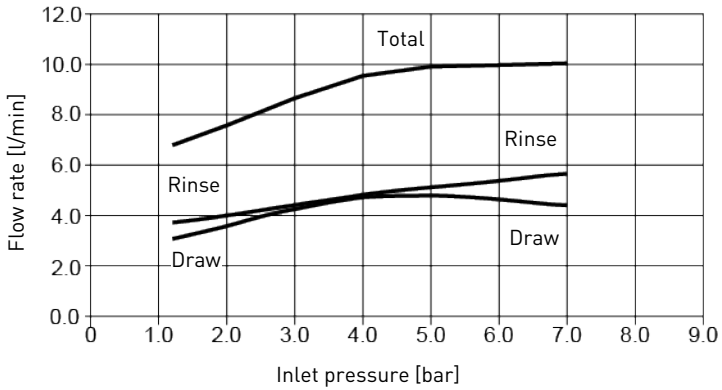

INJECTOR 4C

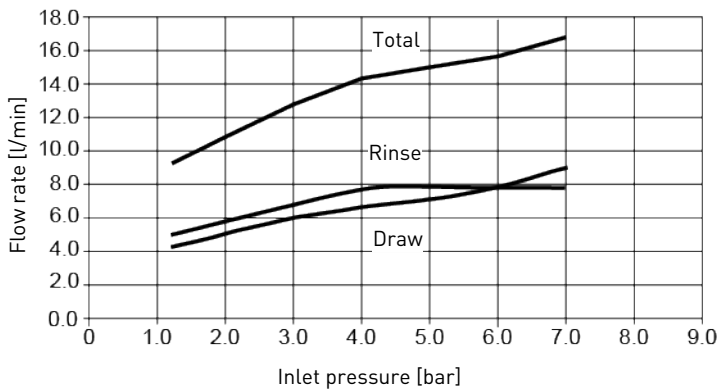

INJECTOR 5C

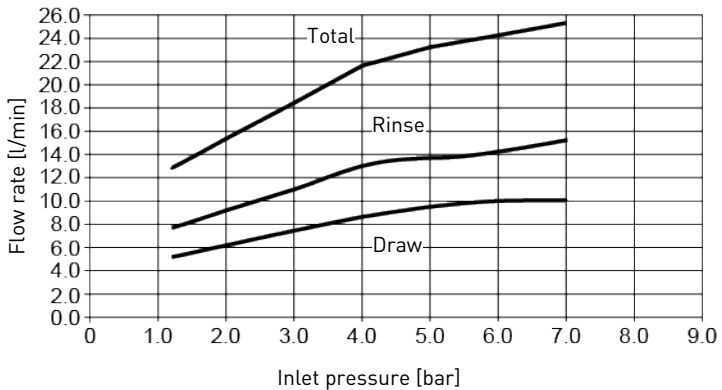

5 Installation

CAUTION



Risk of injury due to electrical shock or pressurized elements !

It is strictly forbidden for not qualified personal, to accede to system's internal parts to perform any kind of technical action.

Be sure to disconnect the electrical power, close the water inlet and depressurize the system before opening the front cover to access internal parts !

5.1 Warnings

The manufacturer will not be held liable for any damages to people or properties resulting from an improper use of the device not compliant with the following instructions.

Whenever this guide doesn't clarify all doubts about installation, service or maintenance, please contact the technical support of the company that has installed the device.

Device installation must be done by a qualified technician according to the current standards and regulations, using tools compliant with a device for a safety use and referring to that technician also for device maintenance.

In case of out of order or malfunction, before performing any kind of action on the device, please ensure to have disconnected the transformer from the power source, to shut off inlet water supply to the valve and to drain water pressure opening a tap down-line of the valve.

1. Be careful when removing the valve from the box and during subsequent handling, weight is liable to cause damage to property and persons in case of accidental impact.
2. Before sending the water on the valve, make sure that all plumbing connections are tight and properly implemented in order to avoid dangerous leaks of pressurized water.
3. Use caution when installing welded metal piping near the valve, the heat may damage the plastic body of the valve and the bypass.
4. Be careful not to let the full weight of the valve on fittings, pipes or bypass.
5. Make sure that the environment in which the valve is installed does not reach freezing temperatures of the water, the valve may be damaged.
6. Make sure that the tank containing the resin is vertical; otherwise the resin could enter in the valve and damage it.

5.2 Safety notices for installation

- Observe all warnings that appear in this manual;
- only qualified and professional personnel are authorized to carry out installation work.

5.3 Installation environment

5.3.1 General

- Use only brine salts designed for water softening. Do not use ice melt, block, or rock salts;

- keep the media tank in an upright position. Do not turn on its side, upside down, or drop it. Turning the tank upside down may cause media to enter the valve or might clog the upper screen;
- follow State and local codes for water testing. Do not use water that is micro-biologically unsafe or of unknown quality;
- when filling the media tank, first place the valve in the backwash position, then partly open the valve. Fill the tank slowly to prevent media from exiting the tank;
- when installing the water connection (bypass or manifold), first connect to the plumbing system. Allow heated parts to cool and cemented parts to set before installing any plastic parts. Do not get primer or solvent on O-rings, nuts, or the valve.

5.3.2 Water

- Water temperature must not exceed 43°C for standard version, 65°C for volumetric hot water version and 82°C for time clock hot water version;
- a minimum of 1.8 bar of water pressure is required for the regeneration valve to operate effectively.

Mandatory



Do not exceed a maximum of 8.6 bar inlet pressure. In such cases, it is necessary to install a pressure regulator upstream the system.

5.3.3 Electrical

There are no user-serviceable parts in the AC/AC or AC/DC transformer, motor, or controller. In the event of a failure, these should be replaced.

- All electrical connections must be completed according to local codes;
- use only the power AC/AC or AC/DC transformer that is supplied;

Mandatory



The use of any other power transformer than the one supplied void the warranty of all electronic parts of the valve !

- the power outlet must be grounded;
- to disconnect power, unplug the AC/AC or AC/DC transformer from its power source;
- an uninterrupted current supply is required. Please make sure that the voltage supply is compatible with the unit before installation;
- make sure the controller power source is plugged in;
- if the electrical cable is damaged, it is imperative that it is replaced by a qualified personnel.

5.3.4 Mechanical

Caution - material



Risk of damage due to wrong lubricant use !

Do not use petroleum-based lubricants such as vaseline, oils, or hydrocarbon-based lubricants.

Use only approved silicone grease or soapy water !

- All plastic connections should be hand-tightened. PTFE (plumber's tape) may be used on connections that do not use an O-ring seal. Do not use pliers or pipe wrenches;
- existing plumbing should be in a good shape and free from limescale. In case of doubt, it is preferable to replace it;
- all plumbing must be completed according to local codes and installed without tension or bending stresses;
- soldering near the drain line should be done before connecting the drain line to the valve. Excessive heat will cause interior damage to the valve;
- do not use lead-based solder for sweat solder connections;
- the riser tube should be cut flush with the top of the tank to 19 mm below the top of the tank. Slightly bevel the ridge in order to avoid deterioration of the seal whilst fitting the valve;
- the drain line must be a minimum of 12.7 mm (1/2") in diameter. Use 19 mm (3/4") pipe if the backwash flow rate is greater than 26.5 lpm or the pipe length is greater than 6 m;
- do not support the weight of the system on the valve fittings, plumbing, or the bypass;
- it is not recommended to use sealants on the threads. Use PTFE (plumber's tape) on the threads of the drain elbow, and other NPT/BSP threads;
- the installation of a pre-filter is always recommended (100µ nominal);
- valve inlet/outlet must be connected to main piping via flexible.

5.4 Integration constraints

Location of a water treatment system is important. The following conditions are required:

- flat and firm level platform or floor;
- room to access equipment for maintenance and adding brine (salt) to tank;
- constant electrical supply to operate the controller;
- total minimum pipe run to water heater of 3 m (10 ft) to prevent backup of HW into system;
- always install check valve before water heater to protect the softener from HW return;
- local drain for discharge as close as possible;
- water line connections with shut off or bypass valves;
- must meet any local and state codes for site of installation;
- valve is designed for minor plumbing misalignments. Do not support weight of system on the plumbing;
- be sure all soldered pipes are fully cooled before attaching plastic valve to the plumbing.

5.5 Valve connection to piping

The connections should be hand tightened using PTFE (plumber's tape) on the threads if using the threaded connection type.

In case of heat welding (metal type connection), the connections should not be made to the valve when soldering.

Tip



See chapter Components description and location [Page 19] to identify the connections.

When pressurized, any composite tank will expand both vertically and circumferential. In order to compensate the vertical expansion, the piping connections to the valve must be flexible enough to avoid overstress on the valve and tank.

5.5.1 Top-mounted valve installation

The valve and tank should not be supporting any part of the piping weight. This is hence compulsory to have the piping fixed to a rigid structure (e.g. frame, skid, wall...) so that the weight of it is not applying any stress on the valve and tank.

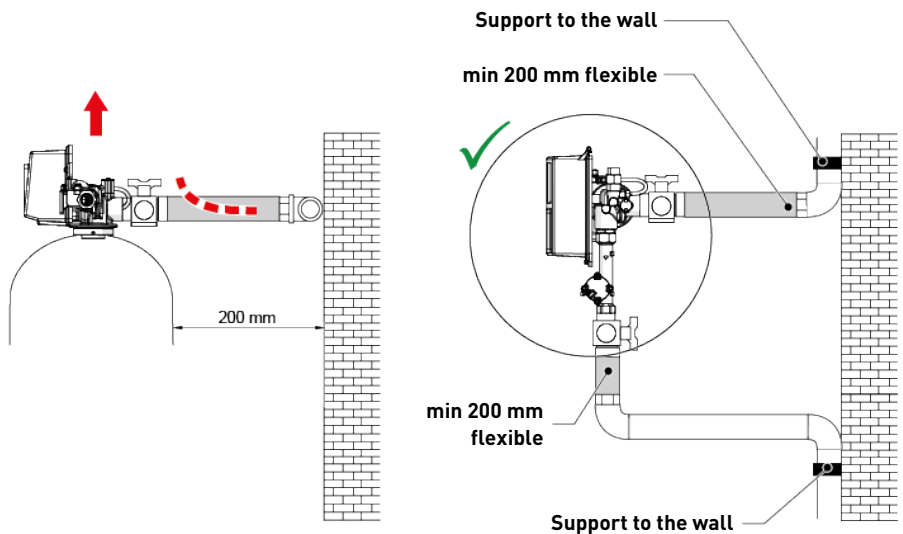

- The diagrams above illustrate how the flexible piping connection should be mounted;
- in order to adequately compensate the tank elongation the flexible tubes must be installed **horizontally**;
- should the flexible piping connection be installed in vertical position, instead of compensating the elongation, it will create additional stresses on the valve & tank assembly. Therefore this is to be avoided;
- the flexible piping connection must also be installed stretched, avoiding excessive length. For instance 20 – 40 cm is enough;

- excessively long and non-stretched flexible piping connection will create stresses on the valve and tank assembly when the system is pressurized, as illustrated in the below picture: on the left the assembly when the system is unpressurized, on the right the flexible piping connection when put under pressure tends to lift up the valve when stretching up. This configuration is even more dramatic when using semi-flexible piping;
- failure to provide enough vertical compensation may lead to different kinds of damage, either on the valve thread which is connected to the tank, or on the female thread connection of the tank. In some cases, damage may also be seen on the valve inlet and outlet connections;

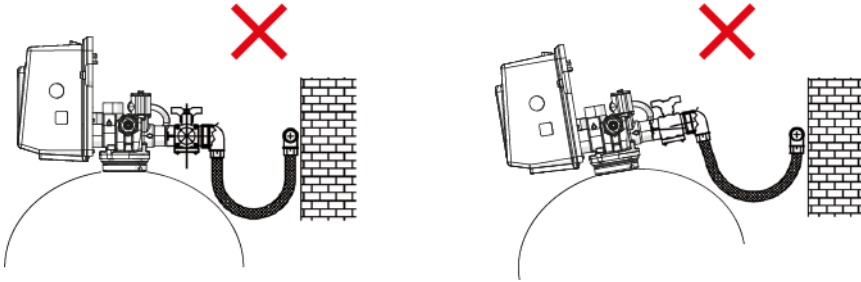

- in any case, any failure caused by improper installations and/or piping connections may void the warranty of Pentair products;
- in the same way, using lubricant* [▶ Page 40] on the valve thread is not allowed and will void the warranty for the valve and tank. Indeed using lubricant there will cause the valve to be over-torqued, which may lead to valve thread or tank thread damage even if the connection to piping has been done following the above procedure.

*Note: Use of petroleum-based grease and mineral based lubricant is totally forbidden, not only on the valve thread, since plastics used (especially Noryl) will highly suffer from contact with this type of grease, leading into structural damage hence to potential failures.

5.5.2 Side-mounted valve installation

Valid for location having a reduced height.

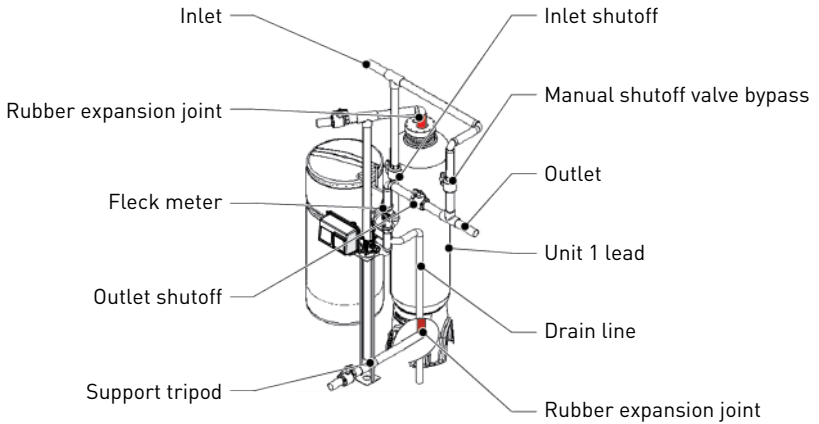

- To avoid the piping supporting the valve and side adapter weight, they must be fixed on a tripod or any other appropriate support;
- in order to adequately compensate the tank elongation, the rubber expansion joints must be mounted on the top and bottom of the tank. In red on the diagram above.

5.6 Block diagram and configuration example

Block diagram

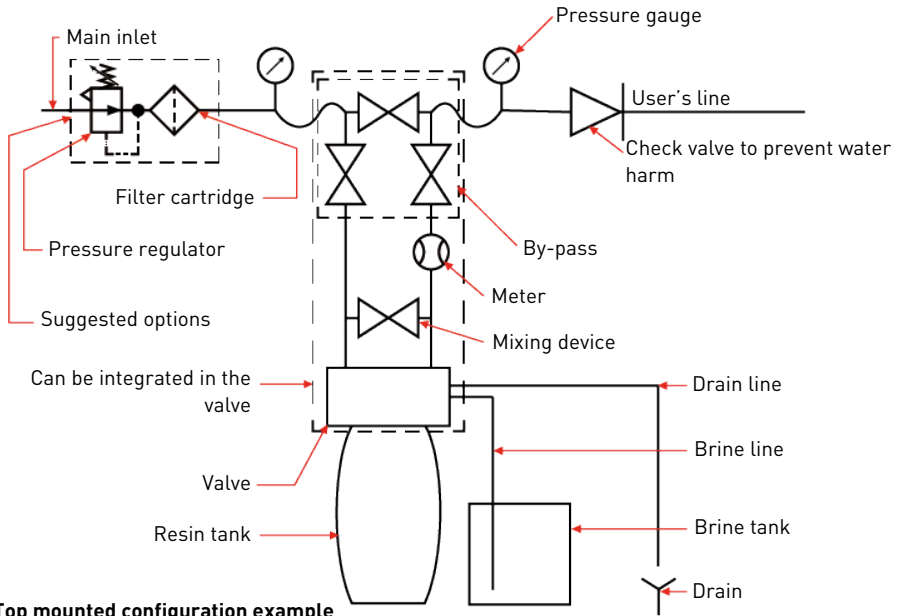

Top mounted configuration example

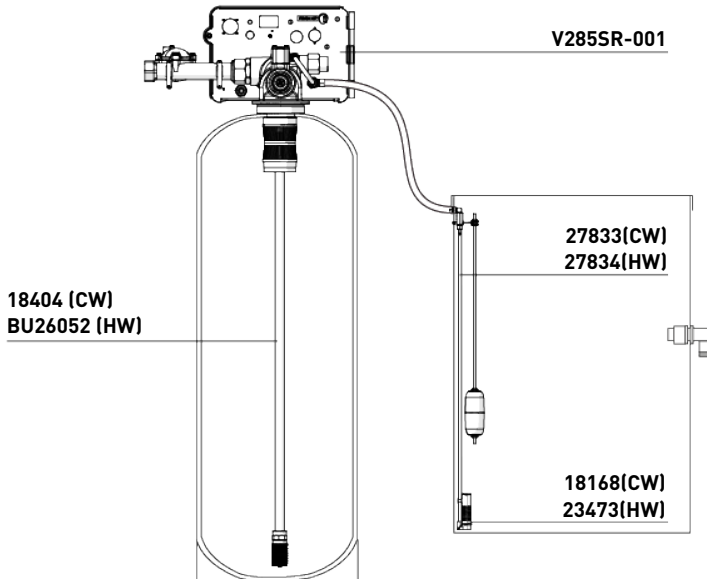

Side mounted configuration example

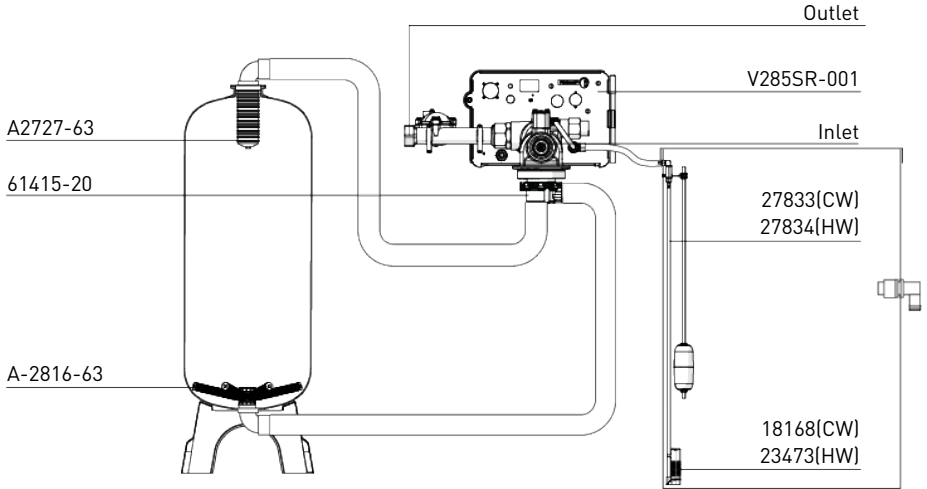

5.7 Regeneration flows

Info



For all regeneration types, the valve has the options with or without NBP (no hard water coming out from outlet during regeneration).

Metered immediate control

A meter immediate control measures water usage and regenerates the system as soon as the calculated system capacity is depleted. The control calculates the system capacity by dividing the unit capacity (typically expressed in °TH*m3 volume) by the feedwater hardness and subtracting the reserve. Meter Immediate systems generally do not use a reserve volume. A Meter Immediate control will also start a regeneration cycle at the programmed regeneration time if a number of days equal to the regeneration day override pass before water usage depletes the calculated system capacity.

Metered delayed control

A Meter Delayed Control measures water usage and regenerates the system at the programmed regeneration time after the calculated system capacity is depleted. As with Meter Immediate systems, the control calculates the system capacity by dividing the unit capacity by the feedwater hardness and subtracting the reserve. The reserve should be set to insure that the system delivers treated water between the time the system capacity is depleted and the actual regeneration time. A Meter Delayed control will also start a regeneration cycle at the programmed regeneration time if a number of days equal to the regeneration day override pass before water usage depletes the calculated system capacity.

Time clock delayed control

A Time Clock Delayed Control regenerates the system on a timed interval. The control will initiate a regeneration cycle at the programmed regeneration time when the number of days since the last regeneration equals the regeneration day override value.

Day of the week control

This control regenerates the system on a weekly schedule. The schedule is defined in Master Programming by setting each day to either "OFF" or "ON." The control will initiate a regeneration cycle on days that have been set to "ON" at the specified regeneration time.

5.8 Electrical connections

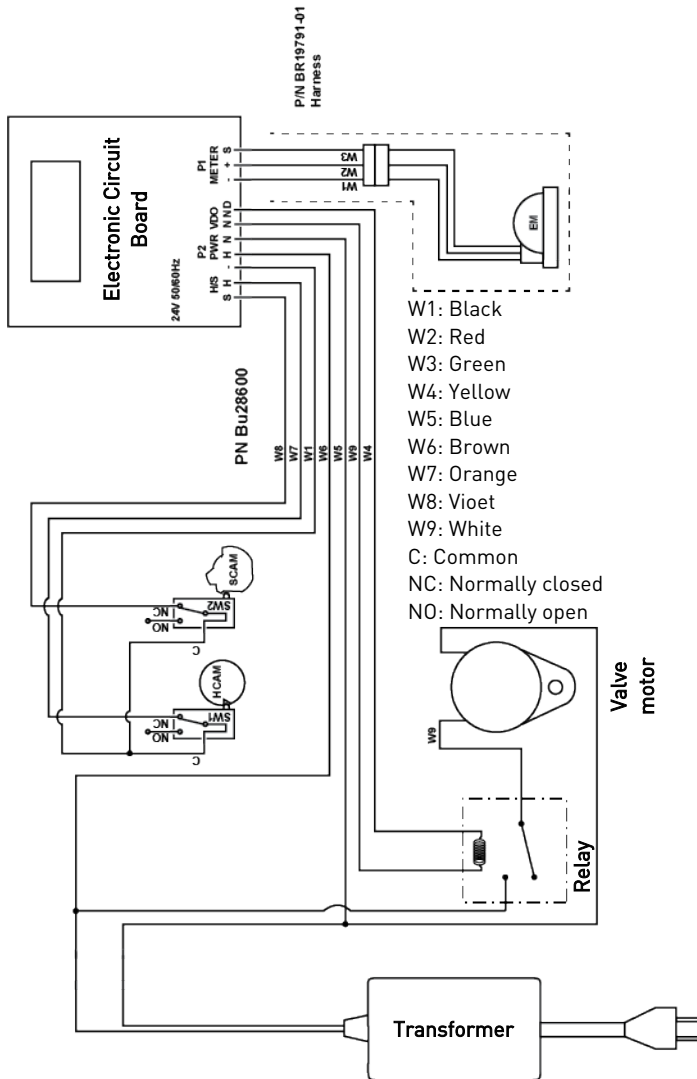

Info



The microswitches are connected on C and NC.

5.9 Bypassing

A bypass valve system should be installed on all water conditioning systems. Bypass valves isolate the softener from the water system and allow unconditioned water to be used. Service or routine maintenance procedures may also require that the system is bypassed.

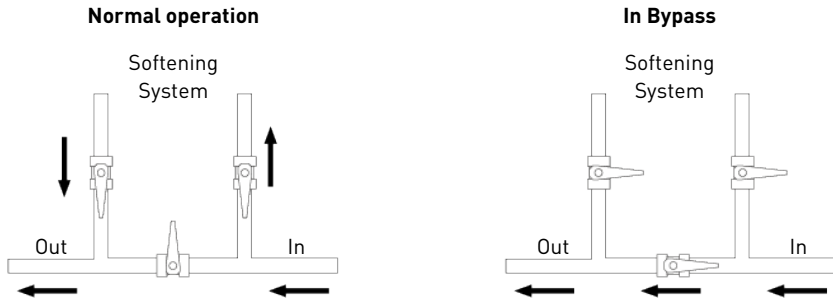

Caution - material



Risk of damage due to bad mounting !

Do not solder pipes with lead-based solder.

Do not use tools to tighten plastic fittings. Over time, stress may break the connections.

Do not use petroleum grease on gaskets when connecting bypass plumbing. Use only 100% silicone grease products when installing any plastic valve. Non-silicone grease may cause plastic components to fail over time.

5.10 Drain line connection

Info



Standard commercial practices are expressed here.

Local codes may require changes to the following suggestions.

Check with local authorities before installing a system.

Mandatory



The drain line must be build with 1" PVC rigid tube ! An air gap must be present at the drain!



CAUTION

Risk of injury due to whipping hose !

Flexible and semi-flexible hoses may bend and whip during draining.

The drain line may be elevated up to 1.8 m provided the run does not exceed 4.6 m and water pressure at the softener is not less than 2.76 bar. Elevation can increase by 61 cm for each additional 0.69 bar of water pressure at the drain connector.

Where the drain empties into an overhead sewer line, a sink-type trap must be used.

Secure the end of the drain line to prevent it from moving.

Mandatory



Waste connections or the drain outlet shall be designed and constructed to provide connection to the sanitary waste system through an air-gap of 2 pipe diameters or 50.8 mm (2"), whichever is larger.

Caution - material



Risk of damage due to lack of gap !

Never insert the drain line directly into a drain, sewer line or trap. Always allow an air gap between the drain line and the waste water to prevent the possibility of sewage being back-siphoned into the softener.

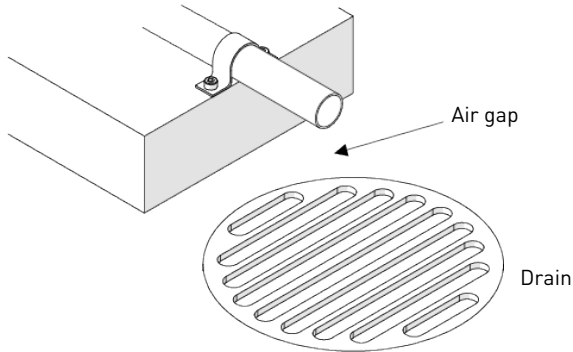

5.11 Overflow line connection

In the event of a malfunction, the brine tank overflow fitting will direct “overflow” to the drain instead of spilling on the floor. This fitting should be on the side of the brine tank. Most brine tank manufacturers feature a pre-drilled hole for the tank overflow connector.

To connect the overflow line, locate the hole on the side of the tank. Insert the overflow fitting into the tank and tighten with plastic thumb nut and gasket as shown below. Attach a 25.4 mm (1”) I.D. tubing (not supplied) to fitting and run to drain.

Do not elevate overflow higher than overflow fitting.

Do not tie into the drain line of the controller unit. The overflow line must be a direct, separate line from overflow fitting to drain, sewer or tub. Allow an air gap as per drain line instructions.

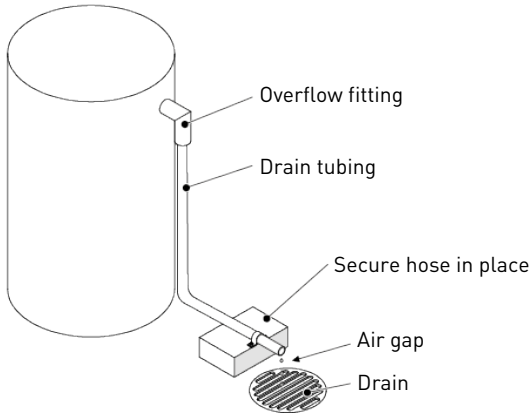

Caution - material



Risk of flooding due to lack of floor drain !

Floor drain is always recommended to avoid flooding in case of overflow.

5.12 Brine line connection

Mandatory



For brine line with 1600/1650 brine valve, use 3/8" semi rigid piping !

For brine line with 1700/1710 brine valve, use 1/2" semi rigid or rigid piping !

Caution - material



Risk of malfunction due to the use of wrong equipment !

Flexible and semi-flexible hoses may shrink because of the vacuum during brine draw.

The brine line from the tank connects to the valve. Make the connections and hand tighten. Be sure that the brine line is secure and free from air leaks. Even a small leak may cause the brine line to drain out, and the softener will not draw brine from the tank. This may also introduce air into the valve, causing problems with the valve operation.

Brine line must be equipped with brine tank air check in the brine tank.

6 Programming

6.1 Display

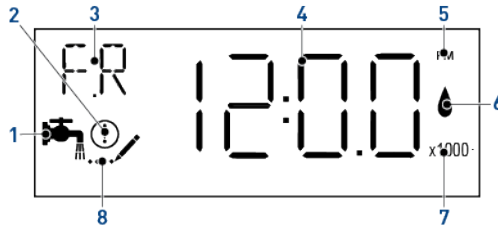

1. Service icon

- Appears in service mode;
- Flashes if a regeneration cycle has been queued.

2. Error / Information icon

- Appears in case of error, see Troubleshooting [▶Page 86], or in diagnostic mode, see.Diagnostic [▶Page 61]

3. Parameter display

Master programming and diagnostic modes:

- C: Unit capacity;
- CD: Current day;
- CT: Regeneration control type;
- DF: Display format;
- Dn, n=1 to 7: Day of week;
- DO: Days override;
- FM: Flow meter;
- FR: Current flow rate;
- H: Feedwater hardness;
- HR: Hours in service;
- K: Meter pulse;
- NT: Number of tanks;
- PF: Peak flow rate;
- RC: Reserve capacity;
- RS: Reserve selection;
- RT: Regeneration time;
- SF: Safety factor;
- SV: Software version;
- TD: Time of day;
- TS: Tank in service;
- VT: Regeneration flow;
- VU: Volume used.

Regeneration cycles:

- B1: First backwash (for dF2b regeneration flow);
- B2: Second backwash (for dF2b regeneration flow);
- BD: Brine draw;
- BF: Brine fill;
- BW: Backwash;
- RR: Rapid rinse.

- 4. Data display
- 5. PM indicator
 - Appears if controller set in US unit.
- 6. Flow indicator
 - Flashes when outlet flow is detected.
- 7. x1000 indicator
 - Appears when the displayed number is bigger than 9999.
- 8. Programming icon
 - Appears in programming modes.

6.2 Commands

Info



Menus are displayed in a defined and incremental order.

If none of the buttons are pushed for 5 minutes in the Programming mode, or if there is a power failure, the controller returns to Service mode without saving.

Mandatory



In order to store the new settings in the programming mode, it is necessary to go through all the parameters !

1. Press to pass to the next step.
2. Use and to adjust the values.

6.3 Setting the time of the day (TD)

Set the time in the system.

1. Press and hold or until the programming icon replaces the service icon and the parameter display reads TD.
2. Set the time with or .
3. Press to validate the selection and return to the service mode, or wait for 10 seconds.

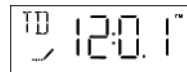





6.4 Basic programming

6.4.1 Basic programming mode chart

Parameter		Options	Definition	Note
DO	Days override	0 to 99	Day	-

Parameter		Options	Definition	Note
RT	Regeneration time	00:00:00 to 23:59:59	Hour	Regeneration time will not appear unless regeneration day override is on.
H	Feedwater hardness	1 to 1990	°TH, ppm or grains	Only displayed for volumetric regenerations.
RC	Fixed reserve capacity	0 to 50	%	Only displayed for volumetric regenerations and if set in reserve selection.
SF	Safety factor	0 to 50	%	Only available if set in reserve selection.
CD	Current day	1 to 7	Day of the week	-



6.4.2 Day of override (DO)

1. Press  and  simultaneously for 5 seconds to enter the menus sequence.
2. Select the number of days of override with  and .
3. Press  to validate the selection and advance to the next parameter.





6.4.3 Regeneration time (RT)

Determine the time of regeneration.

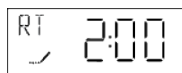
1. Adjust the regeneration time with  and .
2. Press  to validate the selection and advance to the next parameter.



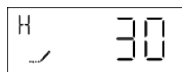

6.4.4 Feed water hardness (H)

1. Adjust the water hardness with  and .
2. Press  to validate the selection and advance to the next parameter.



6.4.5 Reserve capacity (RC) or (SF)

Determine the reserve capacity in litre or in percentage.

1. Adjust the reserve capacity with  and .
2. Press  to validate the selection and advance to the next parameter.

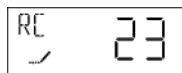

6.4.6 Current day of the week (CD)

Determine the day of regeneration.

Info



Appears only if the softener is set to "weekly time clock".

1 for Monday, 2 for Tuesday, 3 for Wednesday, 4 for Thursday, 5 for Friday, 6 for Saturday and 7 for Sunday.

1. Adjust the day of the week with ▼ and ▲.
2. Press to validate the selection and exit the basic programming mode.



6.5 Master programming mode

Info



As soon as programming mode is entered, all parameters can be displayed or set to suit the needs.

Depending on the current programming, some functions will not be displayed or will not be changeable.

6.5.1 Master programming mode chart

Parameter		Options	Definition	Note
DF	Display format	GAL	US units	-
		Ltr	Metric units	-
VT	Regeneration flow	dF1b	Std DF single backwash	-
		dF2b	Std DF double backwash	-
		FLtr	Filter	To be used with standard piston only.
		UFbd	UF brine first	-
		UFlt	UF filter	To be used with UF piston only.
		Othr	Other	-
CT	Regeneration control type	Fd	Metered delayed	-
		FI	Metered immediate	-
		tc	Time clock	-
		dAY	Day of the week	-
NT	Number of tanks	1	Single tank system	-
		2	Double tanks system	-
TS	Tank in service	U1	Tank 1 in service	Only displayed for double tanks system.
		U2	Tank 2 in service	

Parameter		Options	Definition	Note
C	Unit capacity	0.1 to 9'999'000	°TH*m ³	Only displayed for volumetric regenerations.
V	Filter capacity	1 to 999'900	L	Only displayed for filter.
H	Feedwater hardness	1 to 1990	°TH, ppm or grains	Only displayed for volumetric regenerations.
RS	Reserve selection	SF	Safety factor	-
		rc	Fixed reserve capacity	-
SF	Safety factor	0 to 50	%	Only available if set in reserve selection.
RC	Fixed reserve capacity	0 to 50	%	Only displayed for volumetric regenerations and if set in reserve selection.
DO	Days override	0 to 99	Day	-
RT	Regeneration time	00:00:00 to 23:59:59	Hour	Regeneration time will not appear unless regeneration day override is on.
B1	First backwash	0 to 199	Minute	Only displayed for dF2b regeneration flow. In case of dF1b regeneration flow, the screen shows BW.
BD	Brine draw			BD consist of time for brine draw and slow rinse.
B2	Second backwash			Only shown in dF2b regeneration flow.
RR	Rapid rinse			-
BF	Brine fill	0 to 199	Minute	-
BW	Backwash			-
Rn	Cycle number n=1 to 6			Only if "Othr" is chosen under VT. R1, R2, R3, etc... will be displayed instead.
Dn	Day of week, n=1 to 7	ON - OFF	-	Regeneration setting for each day of the week. OFF by default.
CD	Current day	1 to 7	Day of the week	-
FM	Flow meter type	P0.7	¾" paddle wheel	-
		t0.7	¾" turbine	-
		P1.0	1" paddle wheel	-
		t1.0	1" turbine	-
		P1.5	1½" paddle wheel	-
		t1.5	1½" turbine	-
		P2.0	2" paddle wheel	-
		Gen	Generic or non-Fleck	-

Parameter		Options	Definition	Note
K	Meter pulse	0.1 to 999.9	Litre	Only displayed for generic flow meter type.

6.5.2 Entering master programming mode

1. Press and hold ▼ or ▲ until the programming icon replaces the service icon and the parameter display reads TD.
2. Set the time to 12:01 PM with ▼ or ▲.
3. Press  to validate the selection and return to the service mode, or wait for 10 seconds.
4. Press and hold ▼ and ▲ for 5 seconds until the programming icon replaces the service icon and the display format screen appears.

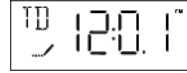

6.5.3 Display format mode (DF)

Select the unit of measure.

Options:

- GAL: U.S. gallons and 12-Hour AM/PM;
- Ltr: litres and 24-Hour.

1. Press ▼ or ▲ to select the unit.
2. Press  to validate the selection and move to the next parameter.

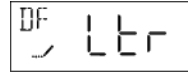

6.5.4 Regeneration flow (VT)

Select the regeneration flow.

Options:

- dF1b: standard downflow single backwash (standard);
- Othr: other;
- UFtr: upflow filter (for 5000 filter);
- UFbd: upflow brine first;
- FLtr: filter, to be used with standard piston only (except 5000);
- dF2b: standard downflow double backwash.

1. Press ▼ or ▲ to select the regeneration flow.
2. Press  to validate the selection and move to the next parameter.



6.5.5 Regeneration control type (CT)

Select the regeneration controller type.

Options:

- Fd: meter delayed;
- Fl: meter immediate;
- tc: time clock;
- dAY: day of the week.

1. Press ▼ or ▲ to select the regeneration control type.
2. Press  to validate the selection and move to the next parameter.



6.5.6 Number of tanks (NT)

Select the number of tanks.

Options:

- NT 1: single tank system;
- NT 2: double tanks system.

Mandatory



Due to the 2850 valve being designed for single tank system only, set valve type to 1.

1. Press ▼ or ▲ until "---1" is displayed.
2. Press ↻ to validate the selection and move to the next parameter.

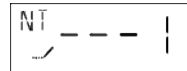

6.5.7 Tank in service (TS)

Info



This parameter appears only if number of tanks (NT) is set to 2.

If it appears, the Vanne valve being a single tank system, go back to number of tanks (NT) and set it to 1.

6.5.8 Unit capacity (C)

Set the unit capacity.

Mandatory



Enter the capacity of the media bed in m³ x °TH or g as CaCO₃ for softener system (C is displayed in the upper left corner) or in litres for filter (V is displayed in the upper left corner) !

Info



The unit capacity parameter is only available if the controller type has been programmed for volumetric regeneration.

The unit capacity can be set from 0.1 to 9999 x 1000 °TH*m³, g as CaCO₃ equivalent or in grains if DF=GAL.

1. Press ▼ or ▲ to select the unit capacity.
2. Press ↻ to validate the selection and to move the next parameter.

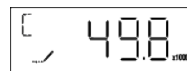

6.5.9 Feedwater hardness (H)

Set the feedwater hardness.

Mandatory





Enter the feedwater hardness in °TH, ppm or grains of hardness for softener system.

Info



The feedwater hardness parameter is only available if the controller type has been programmed for volumetric regeneration.

The feedwater hardness can be set from 1 to 1990 °TH, ppm, or grains.

1. Press  or  to set the feedwater hardness in accordance with display format (DF), see Display format mode (DF) [▶Page 55].
2. Press  to validate the selection and to move the next parameter.

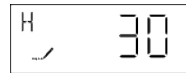

6.5.10 Reserve selection (RS)

Info





This parameter is not useful when regeneration control type (CT) is set to FI.

Set the reserve type.

Options:

- SF: safety factor;
- rc: fixed reserve capacity.

1. Press  or  to set the reserve type.
2. Press  to validate the selection and move to the next parameter.

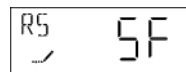



6.5.10.1 Safety factor (SF)

Info



This parameter is not shown if RS is set to rc.

The safety factor can be set from 0 to 50% of the initial volumetric capacity.

1. Press  or  to set the reserve type.
2. Press  to validate the selection and move to the next parameter.

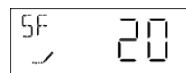

6.5.10.2 Reserve capacity (RC)

Info



This parameter is not shown if RS is set to SF.

The fixed reserve capacity can be set up to a volume equivalent to 50% of the initial volumetric capacity.

1. Press ▼ or ▲ to set the reserve type.
2. Press ↻ to validate the selection and move to the next parameter.

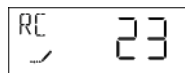

6.5.11 Days override (DO)

Set the maximum number of days between regeneration cycles.

Info



This parameter allows setting the maximum amount of days that the system can stay in service mode without regeneration.

Mandatory



In time clock mode, this parameter must be set and the controller will need at least one regeneration day activated.

Setting the parameter to "OFF" disables this function.

The number of days can be set from OFF, or 1 to 99 days.

1. Press ▼ or ▲ to set the days override.
2. Press ↻ to validate the selection and move to the next parameter.



6.5.12 Regeneration time (RT)

Set the regeneration time.

Info



Regeneration time is the time of the day when regenerations occur for delayed regeneration of any type and calendar override regeneration.

1. Press ▼ or ▲ to set the regeneration time.
2. Press ↻ to validate the selection and move to the next parameter.

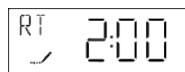

6.5.13 Regeneration cycle step duration

Set the duration in minutes of each regeneration cycle.

Info



Setting a cycle step to 0 will cause the controller to skip that step during regeneration, but keeps the following steps available.



The different regeneration cycles are listed in sequence based on the regeneration flow selected for the system.

All cycles can be set from 0 to 199 minutes.

6.5.13.1 Regeneration abbreviations

B1	First backwash	BF	Brine fill
B2	Second backwash	BW	Backwash
BD	Brine draw	RR	Rapid rinse

6.5.13.2 For pre-set regeneration cycles

1. Press  or  to set the regeneration cycle time.
2. Press  to validate the selection and move to the next parameter.







6.5.14 Day of week (Dn, n = 1 to 7)

Set the day of week for regeneration.

Info



The day of week parameter is only available if "day" mode has been set in controller type selection.

1. Press  or  to set "ON" or "OFF" to set the day as a regeneration day.
2. Press  to validate the selection.
3. Repeat **AC** to AD until **D7** is set.
4. Press  to validate the selection and move to the next parameter.

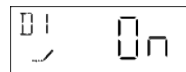

6.5.15 Current day (CD)

Set the current day.

Info



The current day is defined from D1 (Monday) to D7 (Sunday).

1. Press ▼ or ▲ to set the current day.
2. Press ↻ to validate the selection and move to the next parameter.



6.5.16 Flow meter type (FM)

Select the flow meter type.

Options:

- P0.7: ¾" paddle wheel meter (Standard setting for 4600, 5600 and 9100);
- t0.7: ¾" turbine meter;
- P1.0: 1" paddle wheel meter (Standard setting for 2750 and 9000);
- t1.0: 1" turbine meter;
- P1.5: 1½" paddle wheel meter (Standard setting for 2850);
- t1.5: 1½" turbine meter;
- P2.0: 2" paddle wheel meter;
- Gen: generic or other non-Fleck meter.

1. Press ▼ or ▲ to set the flow meter type.
2. Press ↻ to validate the selection and move to the next parameter or exit master programming mode and save modifications done.





6.5.17 Meter pulse

Set the meter pulse for a non-standard flow meter.

Info



The meter pulse parameter is only available if the Gen option has been set in flow meter type selection.

1. Press  or  to set the meter constant in pulses per unit of volume.
2. Press  to validate the selection and to exit the master programming mode.

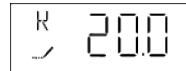

6.6 Filter programming

To use the valve as a filter, in the master programming flow, set the regeneration flow (VT) to filter (FLtr). The controller will let set only the steps necessary to the filter mode, which are: regeneration control type (CT), days override (DO), regeneration time (RT), backwash (BW), rapid rinse (RR), day of week (Dn) and current day (CD).





6.7 Diagnostic

6.7.1 Commands

Info



If none of the buttons are pushed for 1 minute in the diagnostic mode the controller returns to Service mode.

1. Press and hold  and  for five seconds to enter the diagnostic mode.
2. Press  or  to navigate in the diagnostic mode.
3. Press  to exit the Diagnostic mode at any time.

6.7.2 Current flow rate (FR)

Info



The display is updated every second.

1. Current flow rate display (L/min or gpm depending on display format programmed):

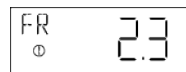

6.7.3 Peak flow rate (PF)

Info



The controller registers the highest flow rate (L/min) since the last regeneration.

1. Peak flow rate display:

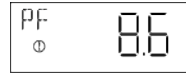

6.7.4 Hours since last regeneration (HR)

Info



Shows the number of hours since the last regeneration, indicating the length of the current service cycle.

1. Hours since last regeneration display:



6.7.5 Volume since last regeneration (VU)

Info



Shows the volume used since the last regeneration (L).

1. Volume since last regeneration display (L or Gal depending on display format programmed):

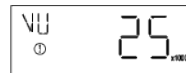

6.7.6 Reserve capacity (RC)

Info



Shows the remaining reserve volume until next regeneration (L).

1. Volume until next regeneration display (L or Gal depending on display format programmed):

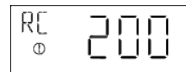

6.7.7 Software version (SV)

Info



Shows the version of the software used by the controller.

1. Software version display:



6.8 Resetting the controller

Mandatory



Once you have completed this operation, check all programming steps !

Info



There are two options to reset: partial and hard reset.

Partial reset will set all the parameters to default values, except volume remaining in volumetric systems and days since last regeneration in time clock systems.

Hard reset will set all the parameters to default values.

6.8.1 Soft reset (SR)

1. Press and hold  and  for 25 seconds while in normal service mode until **SR** is displayed.

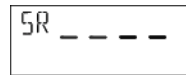

6.8.2 Hard reset (HR)

1. Hold  while powering up the unit.
2. The display shows **HR**.
3. Reprogram all parameters in Master programming mode.

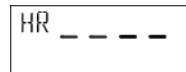

7 Commissioning

Info



This chapter is available for standard regeneration flows. Contact your supplier if the actual regeneration is not standard and if you need assistance.

7.1 Water filling, draining and waterproofness inspection

1. With the bypass still in bypass position (inlet and outlet of the valve closed), plug in the SXT controller to the power source.
2. Proceed to programming according to your system specification if not done yet.
3. Start a manual regeneration by pressing the regen button for 5 seconds. The piston will move into backwash position. If the first cycle is not backwash, quick cycle the valve until the piston is in backwash position. Once in this position, unplug the SXT controller from the power source.
4. With the bypass still in bypass position, open the nearest faucet close to the system.
5. Put the bypass slowly in service position. The valve and tank will slowly get filled with raw water, allowing air to be purged by the drain and/or by the open faucet next to the system. Open the inlet progressively until fully open position.
6. Once the drain runs clear and the bypass valve is fully in service position, plug in again the SXT controller to the power source.
7. Push on the regen button once to move the piston to the next regeneration cycle position. Leave the valve 1 minute in each positions and move to the next one, until refill cycle is displayed. When refill cycle is displayed, let the valve run the entire cycle and check the level of water in the brine tank or cabinet. The level of water in the brine tank should be about 5 cm above the salt platform. You may want to mark the level on the brine tank as this can be used as an indicator for the future lifetime of the softener.
8. Once refill cycle is completed, the valve will automatically go back into service position (unless non-standard regen sequence is programmed). Start again a manual regeneration by pressing for 5 seconds on the regen button. The valve will move to backwash position.
9. Press the regen button once to move to brine draw position. Check to see in the brine tank if the water level decreases.
10. Once the draw function is observed and confirmed (level of water in the brine tank or cabinet has decreased), you may go through each cycle pushing on the regen button until refill cycle, leave the water come back to the "full" level, and then push on the regen button so that the valve returns into service position.
11. Fill the brine tank or cabinet with salt. You may want to mark the level of water in the brine tank/cabinet when completely refilled with water and full of salt. In the future, after each regeneration, you can visually control that the quantity of water refilled should be between the 2 marks done. Marking are optional, but may allow to visually detecting any irregularity during regeneration that may lead to softener inefficiency.
12. With the brine tank completely refilled and full of salt, adjust the safety brine valve in the brine well. Make sure the overflow elbow is installed above the float level.
13. After the softener has been running a few minutes in service, proceed to hardness test on outlet water to make sure the water is treated as per requirements.

The system is ready and in service.

7.2 Sanitization

7.2.1 Disinfection of water softeners

The materials of construction of the modern water softener will not support bacterial growth, nor will these materials contaminate a water supply. In addition, during normal use, a softener may become polluted with organic matter, or in some cases with bacteria from the water supply. This may result in an off-taste or odour in the water.

Thus, your softener may need to be disinfected after installation. Some softeners will require periodic disinfection during their normal lifetime. Consult your installing dealer for more information on disinfecting your softener.

Depending on the conditions of use, the softener type, the type of ion exchanger and the disinfectant available, a choice can be made among the following methods.

7.2.2 Sodium or calcium hypochlorite

These materials are satisfactory for use with polystyrene resins, synthetic gel zeolite, greensand and bentonites.

5.25% Sodium hypochlorite

If stronger solutions are used, such as those sold for commercial laundries, adjust the dosage accordingly.

Dosage

Polystyrene resin: set 1.25 mL fluid per 1 L of resin.

Non-resinous exchangers: set 0.85 mL fluid per 1 L.

Brine tank softeners

Backwash the softener and add the required amount of hypochlorite solution to the well of the brine tank. The brine tank should have water in it to permit the solution to be carried into the softener.

Proceed with the normal regeneration.

Calcium hypochlorite

Calcium hypochlorite, 70% available chlorine, is available in several forms including tablets and granules. These solid materials may be used directly without dissolving before use.

Do not let the disinfectant stand for more than 3 hours in the brine tank before the regeneration start.

Dosage

Measure two grains ~ 0.11 mL for 1 L.

Brine tank softeners

Backwash the softener and add the required amount of hypochlorite to the well of the brine tank. The brine tank should have water in it to permit the chlorine solution to be carried into the softener.

Proceed with the normal regeneration.

7.2.3 Electro chlorination

Valves or systems already equipped with an electrochlorinator device or system will be sanitized during the brine draw phase.

8 Operation

8.1 Display

8.1.1 Display during operation

Examples:

- Valve in service with day time:
- Valve in service with volume remaining before regeneration:
- Remaining days before next regeneration:
- In volumetric regeneration flow, reserve 1223 litres remaining:
- In volumetric regeneration flow, exhausted reserve, immediate or delayed start in regeneration depending on the adjustment:

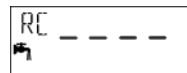
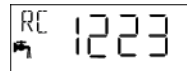
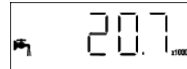
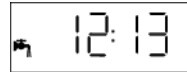

Info



In delayed volumetric mode, the icon  flashes as soon as the reserve begins to be used.

8.1.2 Display during regeneration

During a regeneration the display shows the current cycle step and the time remaining for that cycle. The countdown for the time remaining starts only when the valve is in the cycle displayed.

Examples:

- Refill cycle, 12 min 38 sec. left:
- Rapid rinse cycle, 2 min 17 sec. left:

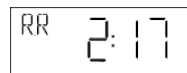
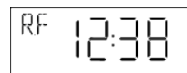

8.2 Recommendations

- Use only regeneration salts designed for water softening in accordance with EN973;
- for optimal system operation, the use of clean salt, free from impurities, is recommended (for example salt pellets);
- do not use ice melt, block, or rock salts;
- the sanitizing process (both with liquid and electrochlorination) may introduce chlorine compounds which may reduce the lifetime of the ion exchange resins. Refer to the technical guides for resins in common use, providing necessary checks on the system.

8.3 Manual regeneration

Mandatory



The controller must be in service in order to enable this procedure !

8.3.1 Manual delayed regeneration

1. Press  once for delayed regeneration.
 - ⇒ The regeneration starts at the programmed regeneration time. See chapter Regeneration time (RT) [► Page 58].
 - ⇒ The service icon flashes.

Info



To cancel: press  again.

The service icon stops flashing.

8.3.2 Immediate regeneration

1. Press and hold  for 5 seconds to initiate immediate manual regeneration regardless from the programmed regeneration control type.

8.3.3 To advance regeneration cycles

1. Press  to pass to the next regeneration cycle.

8.4 Operation during a power failure

- Current valve position, cycle step time elapsed, and time of day is stored 24 hours during a power failure, and will be restored upon power restoration;
- in regeneration, when power is shutting down, the controller saves the current regeneration data. When power is restored, the controller resume the regeneration cycle at the point where power failed;

Caution - material



Risk of damage due to power failure !

Without power, the valve stays in its current position until power is restored.

The system should include all required safety components to prevent overflows resulting from a power failure during regeneration.

-
- all the program settings are stored in a permanent memory;
 - time is kept during a power failure and the time of day is adjusted upon restoration of the power (as long as the power is restored within 24 hours);
 - the time of day on the main display screen will flash when there has been a power failure;
 - the flashing of the time of day can be stopped by pressing any button on the display.

9 Maintenance

Mandatory



Cleaning, maintenance and service operation shall take place at regular intervals and must be done by qualified personnel only in order to guarantee the proper functioning of the complete system.

Report maintenance done in the Maintenance chapter of the User Guide document.

Failure in respecting above instructions may void the warranty!

9.1 General system inspection

Mandatory



Must be done, at minimum, once a year !

9.1.1 Water quality

9.1.1.1 Valve used for softening

1. Raw water total hardness.
2. Treated water hardness.

9.1.1.2 Valve used for filtration

1. Check for raw water analysis and filter's targeted contaminants concentration.
2. Check for treated water analysis and compare with raw water data.

9.1.2 Mechanical Checks

1. Inspect general condition of softener/filter and associated ancillaries and check for any leaks, ensure valve connection to piping is made with adequate flexibility as per manufacturer instruction.
2. Inspection of electrical connections, verify wiring connections and search for evidence of overloading.
3. Verify settings of electronic timer, verify regeneration frequency, and make sure the valve configuration is appropriate for media and tank size.
4. Check water meter, if present, report water meter settings and compare with previous inspection.
5. If water meter is present, verify total water consumption compared to previous visit.
6. If pressure gauges are installed before and after softening/filtering system, verify and record static and dynamic pressure, reporting pressure drop. Verify that inlet pressure respects valve and softening/filtering system limits. Verify that pressure drop stay stable year on year, adapt backwash duration if required.
7. If pressure gauges are not present, but suitable points exist, install temporary pressure gauge(s) to perform precedent point.

9.1.3 Regeneration test

9.1.3.1 Valve used for softening

1. Check condition of brine tank and any associated equipment.
2. Check salt level in brine tank.
3. Initiate regeneration test.
 - ⇒ Check brine draw during brine draw stage.
 - ⇒ Check brine tank refill.
 - ⇒ Check operation of safety brine valve, where fitted.
 - ⇒ Check for brine draw off levels.
 - ⇒ Check for resin loss at the drain during regeneration.
 - ⇒ Where fitted, check for satisfactory operation of solenoid, i.e. outlet shut off during regeneration and/or brine line shut off valve(s).
4. Test and record Total Hardness of outlet water from softener vessel(s).

9.1.3.2 Valve used for filtration

1. Initiate manual regeneration and observe flow to drain.
2. Make sure flow rate correspond to DLFC configuration.
3. Check for media loss at the drain during backwash.
4. Check to see if water runs clear at the end of the backwash cycle.
5. Observe flow fast rinse cycle and measure pressure drop through the filter system. Pressure drop after fast rinse should return equal or very close to pressure drop recorded after system start-up.
6. Where fitted, check for satisfactory operation of solenoid valve(s) i.e. outlet shut off during regeneration.

9.2 Recommended maintenance plan

9.2.1 Valve used for softening

Items	1 year	2 year	3 year	4 year	5 year
Injector & filter	Clean	Clean	Clean	Clean	Clean/ replace if necessary
BLFC***	Clean	Clean	Clean	Clean	Clean/ replace if necessary
DLFC***	Clean	Clean	Clean	Clean	Clean/ replace if necessary
Bypass (if present, contains Orings***)	Clean	Clean	Clean	Clean	Clean/replace if necessary
Piston*	Check/clean/ replace if necessary	Replace	Check/clean/ replace if necessary	Replace	Check/clean/ replace if necessary
Seals & spacers*	Check/clean/ replace if necessary	Replace	Check/clean/ replace if necessary	Replace	Check/clean/ replace if necessary
Brine valve	Check/clean/ replace if necessary	Check/clean/ replace if necessary	Check/clean/ replace if necessary	Check/clean/ replace if necessary	Replace
O-rings***	Check for watertightness /clean or replace in case of leakage	Check for watertightness /clean or replace in case of leakage	Check for watertightness /clean or replace in case of leakage	Check for watertightness /clean or replace in case of leakage	Check for watertightness /clean or replace in case of leakage
Motors	Check	Check	Check	Check	Replace
Gearing	Check	Check	Check	Check	Check/ replace if necessary
Inlet hardness	Check	Check	Check	Check	Check
Residual hardness	Check/adapt mixing screw if necessary	Check/adapt mixing screw if necessary	Check/adapt mixing screw if necessary	Check/adapt mixing screw if necessary	Check/adapt mixing screw if necessary
Electronic/ settings**	Check	Check	Check	Check	Check/ replace if necessary
Transformer**	Check	Check	Check	Check	Check/ replace if necessary
Microswitches	Check	Check	Check	Check	Replace
Meter(s)* (if present)	Check and Clean	Check and Clean	Check and Clean	Check and Clean	Replace
Meter cable(s)* (if present)	Check	Check	Check	Check	Replace

Items	1 year	2 year	3 year	4 year	5 year
Valve watertightness	Check	Check	Check	Check	Check
Valve to piping watertightness	Check	Check	Check	Check	Check

* Wear parts - durability strongly affected by raw water quality and regeneration frequency.

** Electronic parts – durability strongly affected by power source quality and stability.

*** Elastomer durability is strongly affected by raw water concentration in chlorine and its derivative.

9.2.2 Valve used for filtration

Items	1 year	2 year	3 year	4 year	5 year
DLFC***	Clean	Clean	Clean	Clean	Clean/ replace if necessary
Bypass (if present, contains Orings***)	Clean	Clean	Clean	Clean	Clean/replace if necessary
Piston*	Replace	Replace	Replace	Replace	Replace
Seals & spacers*	Replace	Replace	Replace	Replace	Replace
O-rings***	Check for watertightness /clean or replace in case of leakage	Check for watertightness /clean or replace in case of leakage	Check for watertightness /clean or replace in case of leakage	Check for watertightness /clean or replace in case of leakage	Check for watertightness /clean or replace in case of leakage
Motors	Check	Check	Check	Check	Replace
Gearing	Check	Check	Check	Check	Check/ replace if necessary
Electronic/ settings**	Check	Check	Check	Check	Check/ replace if necessary
Transformer**	Check	Check	Check	Check	Check/ replace if necessary
Microswitches	Check	Check	Check	Check	Replace
Meter(s)* (if present)	Check and Clean	Check and Clean	Check and Clean	Check and Clean	Replace
Meter cable(s)* (if present)	Check	Check	Check	Check	Replace
Valve watertightness	Check	Check	Check	Check	Check
Valve to piping watertightness	Check	Check	Check	Check	Check

* Wear parts - durability strongly affected by raw water quality and regeneration frequency.

** Electronic parts – durability strongly affected by power source quality and stability.

*** Elastomer durability is strongly affected by raw water concentration in chlorine and its derivative.

9.3 Recommendations

9.3.1 Use original spare parts

Caution - material



Risk of damage due to use of non-genuine spare parts !

To ensure correct operation and safety of the device, only use original spare parts and accessories recommended by the manufacturer.

Usage of non-genuine spare parts voids all warranties.

Parts to keep in stock for potential replacements are the pistons, S&S kit, injectors, micro-switches and motors. Refer to maintenance sheet.

9.3.2 Use original approved lubricants

- Dow Corning #7 Release Agent.

9.3.3 Maintenance instructions

- Disinfect and clean the system at least once a year or if the treated water has an off-taste or an unusual odor;
- perform a hardness test every year of both inlet and treated water.

9.4 Cleaning and maintenance

9.4.1 First steps

Before any cleaning or maintenance procedure, complete the following steps:

Mandatory



These operations must be performed before any cleaning or maintenance procedure !

1. Unplug the wall-mounted transformer.
2. Shut off water supply or put bypass valve(s) into bypass position.
3. Relieve system pressure before performing any operations.

9.4.2 Power head and/or motor replacement

1. Using a flat screwdriver, unscrew (2) and open the cover (1).
2. Open the controller (3).
3. Using pliers, remove the circlip (11) and free the arm (4).
4. Using a flat screwdriver or a 11 mm wrench remove (10).
5. Using a 19 mm wrench, remove (9) the motor (6) and the power head (5).
6. Remove the microswitches (7) and cams (8), see Micro-switches replacement [▶Page 80], and Cams replacement [▶Page 81].
7. Replace the motor (6) and/or the power head (5).
8. Reverse above procedure steps to rebuild.

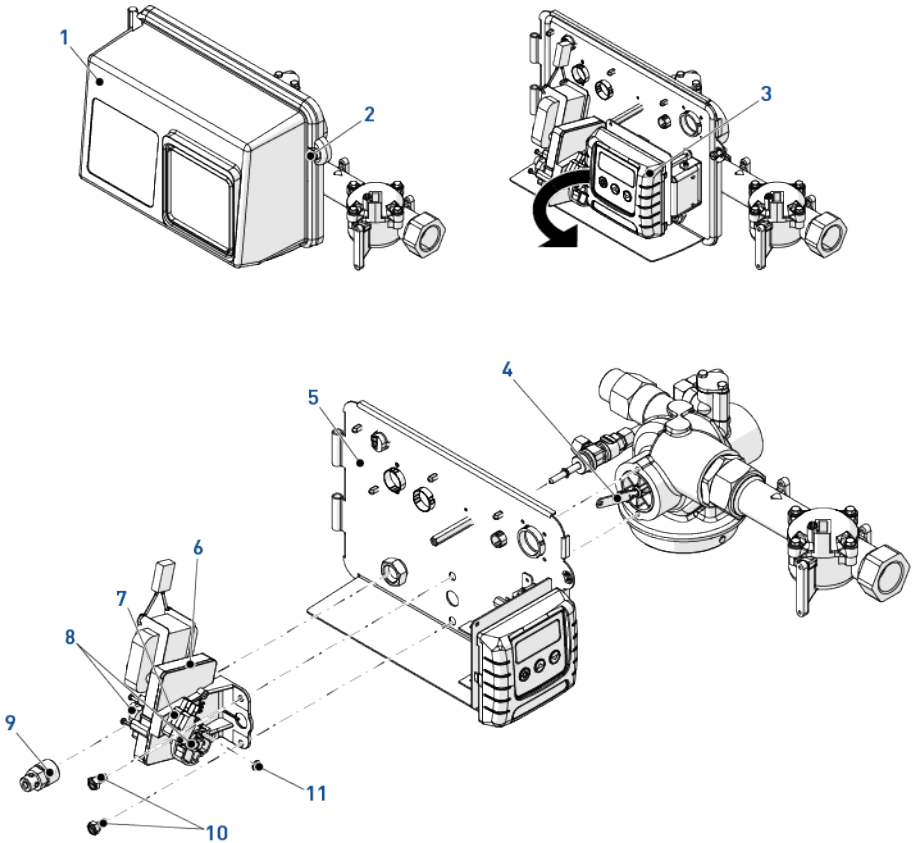

9.4.3 Controller replacement

1. Using a flat screwdriver, unscrew (2) and open the cover (1).
2. Open the controller (3).
3. Press on the clips (5) and remove the controller cover (4).
4. Disconnect the controller (7).
5. Press on the clips (6) and remove the controller (7).
6. Connect the new SXT controller (7), see Electrical connections [Page 45].
7. Reverse above procedure steps to rebuild.

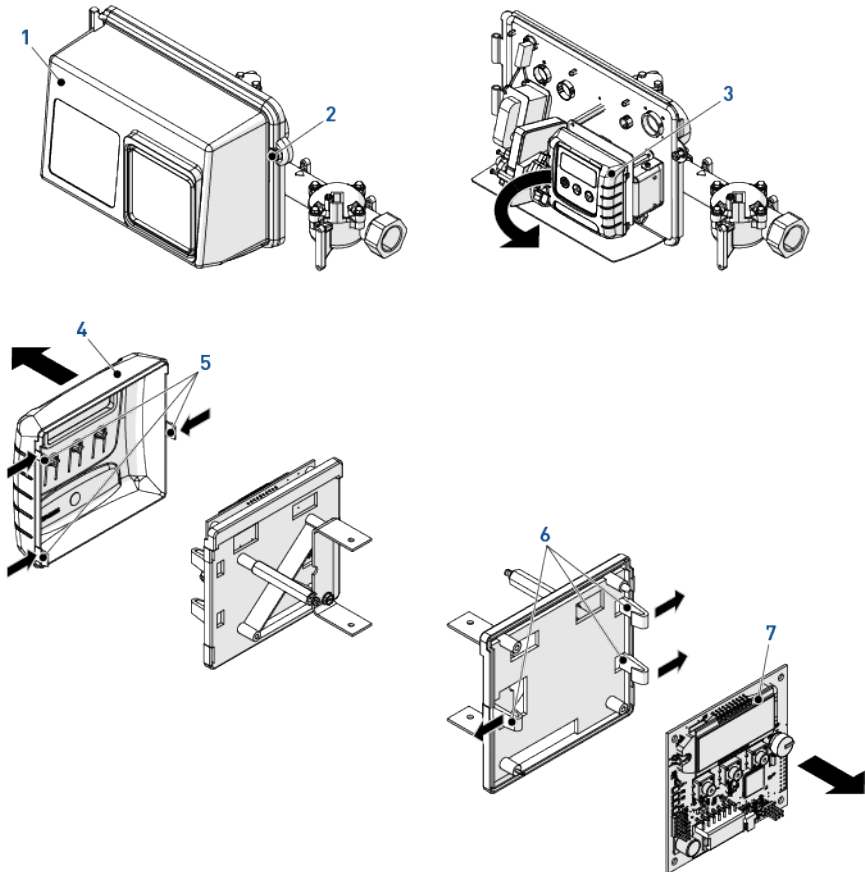

9.4.4 Piston and/or seal and spacer kit disassembly/replacement

1. Remove the power head, see Power head and/or motor replacement [▶ Page 76].
2. Using pliers, remove the pin (5) and the arm (4).
3. Using pliers, remove the piston (3).

Caution - material



Risk of damage on piston due to wrench use !

Using a wrench on piston rod coating will cause leakages.

4. Using a small hook, remove a seal (2).
5. Using the puller, remove a spacer (1).
6. Repeat the two previous steps for all the seals and spacers.
7. Lubricate each new seals (2).
8. Put back a seal (2) using the stuffer.
9. Put back a spacer (1) using the stuffer.
10. Repeat the two previous steps for all the seals and spacers.
11. Lubricate the piston o-ring (3).
12. Put back the piston (3).
13. Put back the arm (4) with the pin (5).
14. Rebuild the power head, see Power head and/or motor replacement [▶ Page 76].

Caution - material



Risk of damage due to wrong lubricant use !

Do not use petroleum-based lubricants such as vaseline, oils, or hydrocarbon-based lubricants.

Use only approved silicone grease or soapy water !

9.4.4.1 Special tools needed

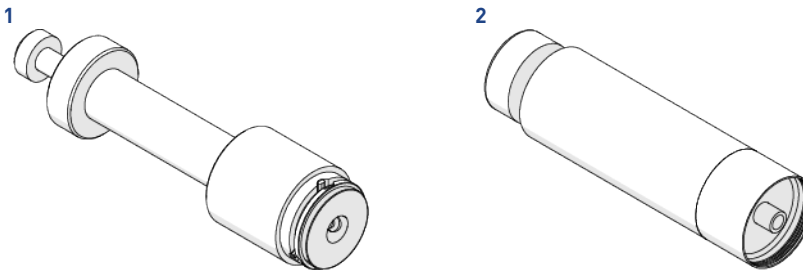

Item	Part number	Description	Packaging quantity
1	17623	Puller 2850/9500	1
2	16516	Stuffer 2850/9500	1

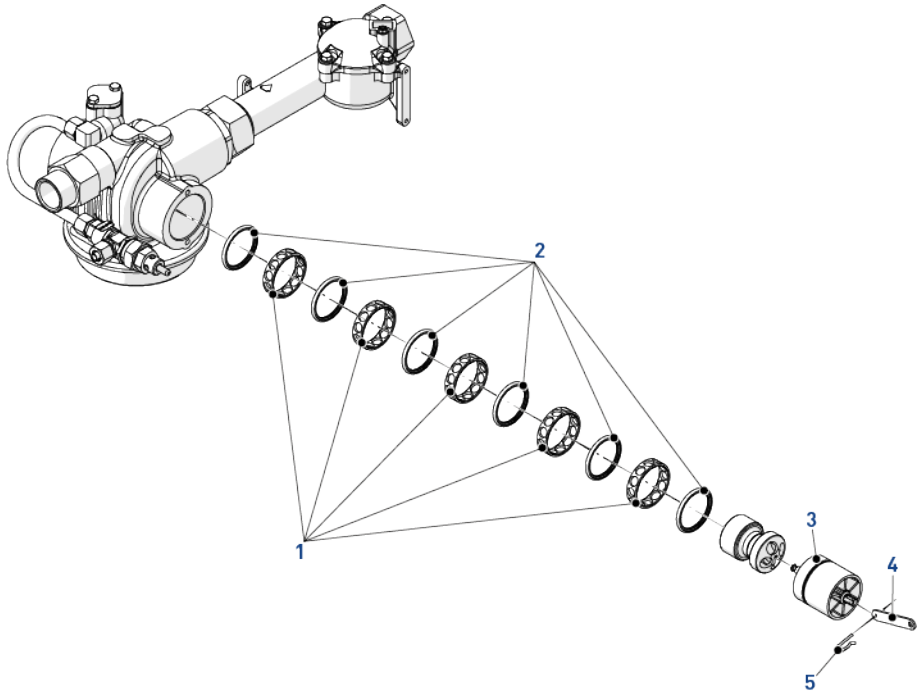

9.4.5 Micro-switches replacement

1. Using a flat screwdriver, unscrew (1) and open the cover (2).
2. Push the controller (3).
3. Using a Phillips screwdriver, unscrew (5).
4. Remove and change the microswitches (4).
5. Reverse above procedure steps to rebuild.

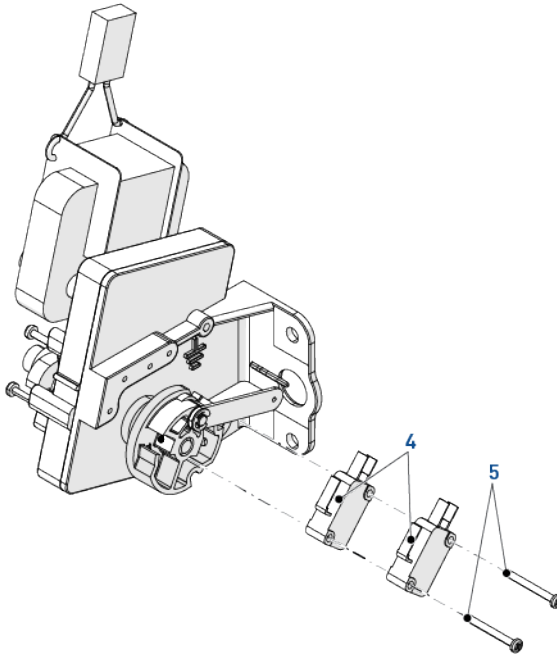
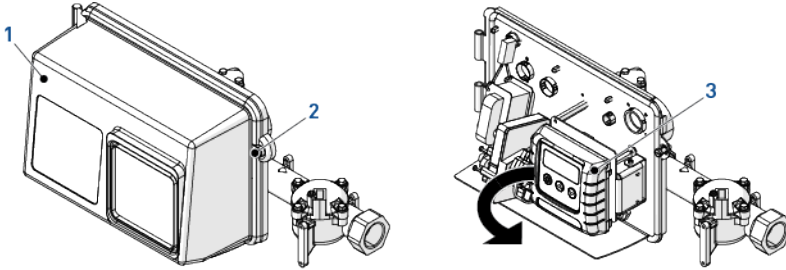

9.4.6 Cams replacement

1. Remove the micro-switches, see Micro-switches replacement [▶ Page 80].
2. Using pliers, remove the circlip **(1)** and free the arm **(2)**.
3. Using pliers, remove the pin(s) **(4 and/or 5)** and the cam(s) **(3 and/or 6)**.
4. Replace the cam(s) **(3 and/or 6)**.
5. Reverse above procedure steps to rebuild.

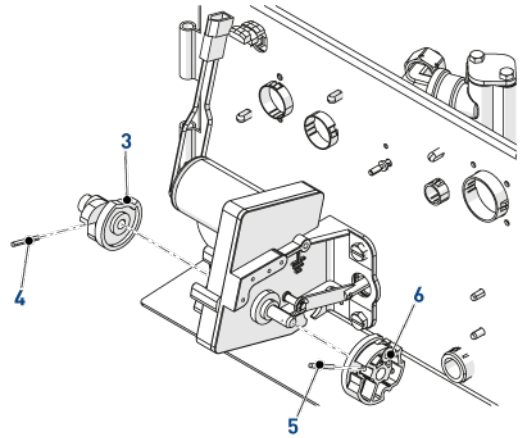
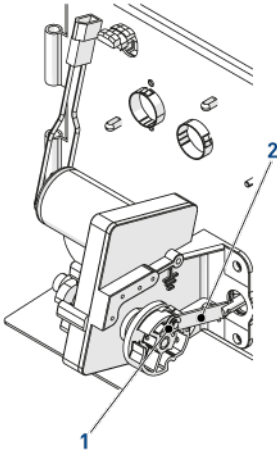

9.4.7 Injector cleaning

1. Using a 16 mm wrench, unscrew the nut (3) to release the tube (4).
2. Using a 8 mm wrench, unscrew (1) and remove the injector assembly (2).
3. Using flat screwdrivers, remove the injector nozzle (7) and the injector throat (8) from the injector body (10).
4. Clean the injector nozzle (7), the injector throat (8) and the filter (9) using compressed air, a soft brush or possibly a pin.
5. Lubricate the gaskets (6) and (11) using silicone grease.
6. Using a 8 mm wrench, assemble as shown the injector on the valve body (12).
7. Tight the nut (3) to fix the tube (4).

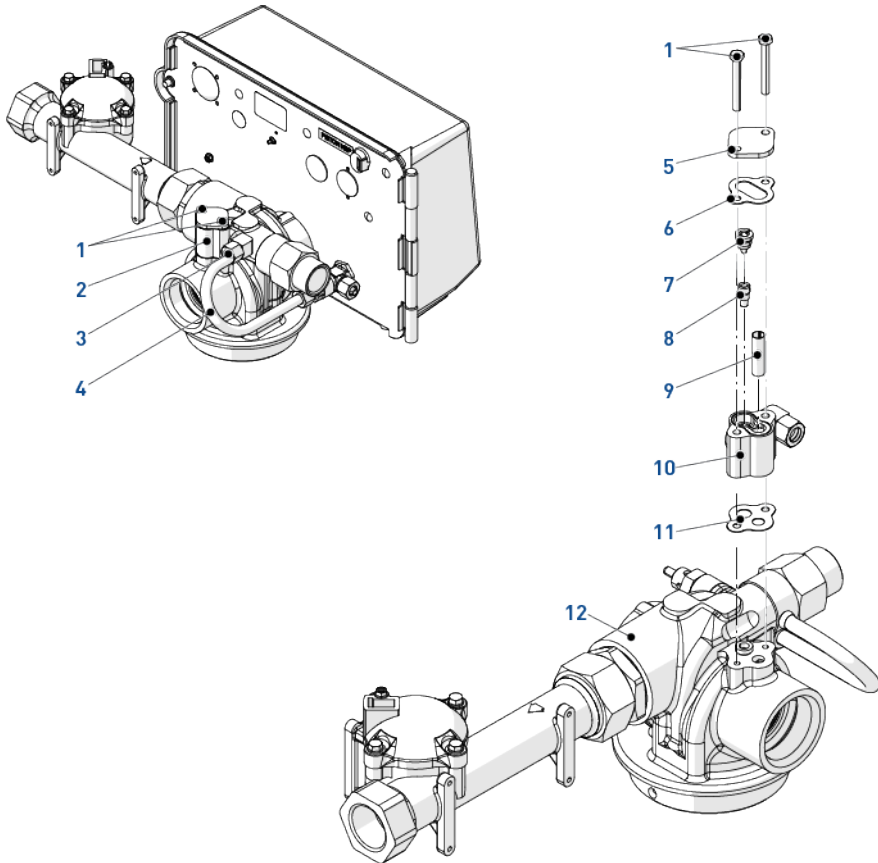

9.4.8 BLFC cleaning

1. Using a 16 mm wrench, unscrew the nuts (2) and remove the tube (1).
2. Using a 18 mm wrench, remove the BLFC holder (3).
3. Using pliers, remove the cage (4) from the BLFC holder (3).
4. Remove the BLFC washer (5) from the cage (4).
5. Change or clean the BLFC washer (5) with a terry cloth.
6. Clean the cage (4).
7. Lubricate the seal (6) with approved lubricant only.
8. Reverse above procedure steps to rebuild.

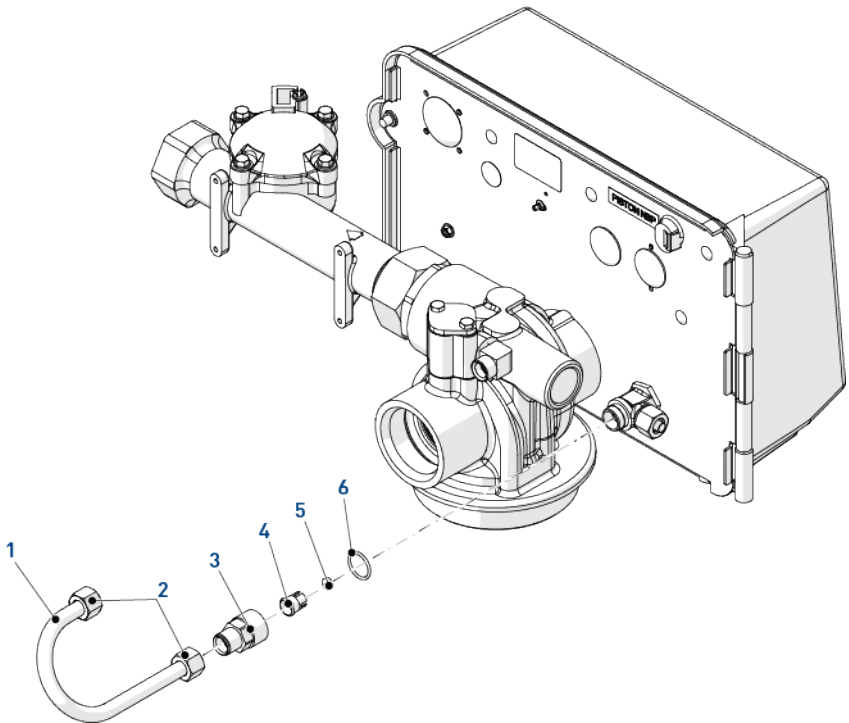

9.4.9 DLFC cleaning

1. Using a 38 mm wrench, remove the DLFC holder (2).
2. Using a flat screwdriver, remove the DLFC (1) from DLFC holder (2).
3. Clean or change the DLFC (1).
4. Reverse above procedure steps to rebuild.

Mandatory



The washers (1) have to be installed with their chamfered side upfront the water stream flow.

Flow indication must be invisible after the washer (1) is placed on the seat (2).

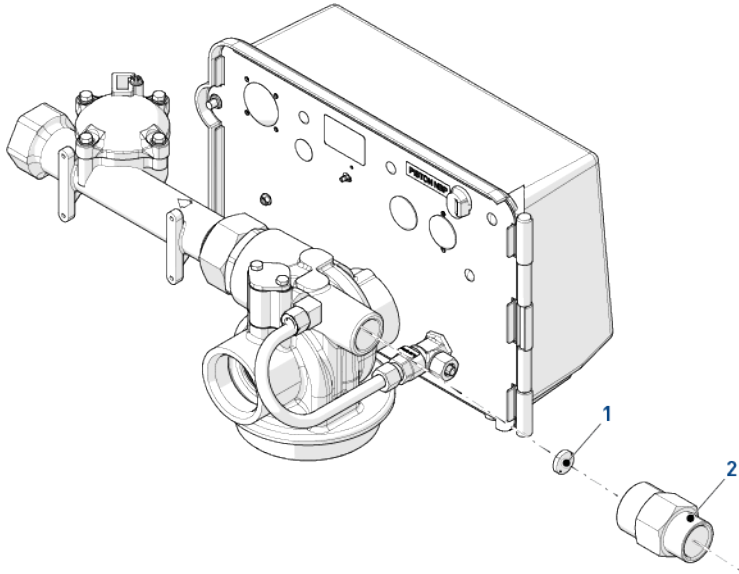

9.4.10 Valve on tank assembly

1. Lubricate the seals with approved silicone grease.
2. Spin the valve (1) onto the tank (2), ensuring the threads are not cross-threaded.
3. Rotate the valve (1) clockwise and freely, without using force until it comes to a stop.

Info



This stop position is considered point zero.

4. Rotate the valve (1) clockwise from point zero to between $\frac{1}{4}$ turn and $\frac{1}{2}$ turn.

Caution - material



Risk of damage due to excessive force !

Do NOT exceed 27 Nm of torque when installing the valve. Exceeding this limit may damage the threads and cause failure.

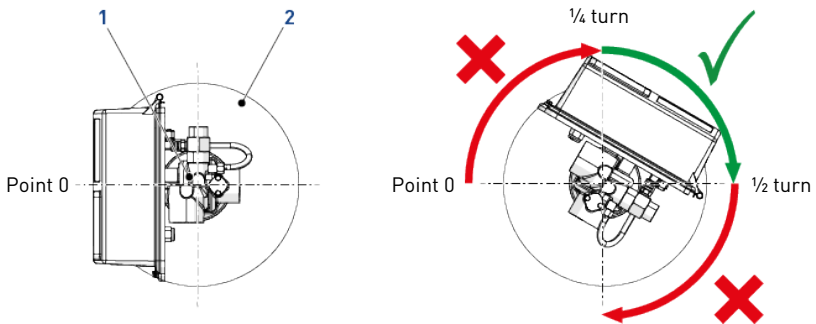

10 Troubleshooting

Problem	Cause	Solution
Softener fails to regenerate automatically	Interrupted power or switched off power source.	Restore the controller and connect to constant power source.
	Disconnected/faulty meter cable.	Check connections in the power head and on the meter cover. Change the cable.
	Defective power cord.	Replace cord.
	Defective motor.	Change motor.
	Defective controller.	Change controller.
	Blocked meter.	Clean or change meter.
	Bad programming.	Program correctly.
Softener delivers hard water	By-pass valve is open.	Close by-pass valve.
	No salt in the brine tank.	Add salt in the brine tank and keep salt level above water level.
	Plugged injector and/or filter.	Clean or replace injector and/or filter.
	Insufficient water flowing into brine tank.	Check brine tank filling time and clean flow regulator.
	Hot water tank hardness.	Repeated flushing of the hot water tank.
	Leak at the distributor hose.	Ensure the distributor tube has no cracks. Check the o-ring.
	Internal valve leak.	Change seals & spacers and/or piston assembly.
	Blocked meter.	Clean or change meter.
	Disconnected/faulty meter cable.	Check connections in the power head and on the meter cover. Change the cable.
Bad programming.	Program correctly.	
Excessive salt consumption	Improper brine refill setting.	Check use of salt and setting of brine refill.
	Too much water in the brine tank.	See problem below: Too much water in the brine tank.
	Bad programming.	Program correctly.
Water pressure drop	Iron deposit in the valve inlet.	Clean the inlet.
	Iron deposit in the valve.	Clean the valve and resin.
	Valve inlet obstructed by foreign elements.	Remove piston and clean the valve.

Problem	Cause	Solution
Resin loss through drain line	Top distributor missing or broken.	Add or replace the top distributor.
	Air in water system.	Ensure the presence of air check system in the brine tank.
	Improperly sized drain line flow control.	Size the drain line flow control correctly.
Iron presence in the valve/treated water	The resin bed is dirty.	Check backwash, brine draw, and brine refill. Regenerate more often and increase backwash cycle time.
	Iron concentration exceeds recommended parameters.	Contact your local dealer.
Too much water in the brine tank.	Plugged drain line flow control.	Clean drain line flow control.
	Plugged injector system.	Clean injector and screen, change if necessary.
	Faulty brine valve.	Change brine valve.
	Bad programming.	Program correctly.
	Controller is not cycling.	Change controller.
	Foreign material in the brine valve.	Replace brine valve seat and clean the valve.
Salted water in service line	Foreign material in the brine line flow control.	Clean brine line flow control.
	Plugged injector and/or filter.	Clean or replace injector and/or filter.
	Power head not operating properly.	Change power head.
	Foreign material in the brine valve.	Replace brine valve seat and clean the valve.
	Foreign material in the brine line flow control.	Clean brine line flow control.
	Low water pressure.	Raise inlet pressure to 1.8 bar minimum.
Bad programming.	Program correctly.	

Problem	Cause	Solution
Softener fails to draw brine	Plugged drain line flow control.	Clean drain line flow control.
	Plugged injector and/or filter.	Clean or replace injector and/or filter.
	Low water pressure.	Raise inlet pressure to 1.8 bar minimum.
	Internal valve leak.	Change seals & spacers and/or piston assembly.
	Bad programming.	Program correctly.
	Power head not operating properly.	Change power head.
Controller cycles continuously	Power head not operating properly.	Change power head.
	Faulty microswitch or wiring loom.	Change microswitch or wiring loom.
	Defective or badly set cycle cam.	Reposition or change cycle cam.
Drain flows continuously	Foreign elements in the valve.	Clean valve and check it in the different regeneration positions.
	Internal valve leak.	Change seals & spacers and/or piston assembly.
	Valve blocked in brine refill or backwash.	
	Defective or blocked motor.	Change motor and check gear teeth.
	Power head not operating properly.	Change power head.
Upper drive synchronization	Power failure while the electronic was compiling data.	System will recover automatically within a few minutes.
	The board doesn't receive the signal from the homing microswitch (motor runs for the 6 first minutes of UD display then shows ER0).	Check microswitches and their wiring.
	Er 0 was shown, power switch off and on.	

10.1 Error detection

Errors codes appear on the service display.

Info



It can take up to 1 minute before an error can be detected and displayed.

10.1.1 Motor stall/cam sense error

Info



The valve drive takes more than 6 minutes to go to the next regeneration cycle and the board hasn't received expected signals from microswitches.

1. Unplug the unit and examine the power head, especially look at homing/step microswitches and motor.
2. Verify all circuit board connections.
3. Verify the motor and gearing components are in good condition and assembled properly.
4. Check the valve and verify that the piston travels freely.
5. Replace/reassemble the various components as necessary.
6. Plug the unit back in and observe its behaviour.
7. If the error reoccurs, unplug the unit.
8. Put it into bypass.
9. Contact dealer.



10.1.2 Motor run-ON error/cycle sense error

Info



The valve performed an unforeseen cycle.

This error message is only valid until controller version 2.6.

1. Unplug the unit and examine the power head.
2. Verify all circuit board connections.
3. Enter master programming mode.
4. Verify that the valve type and system type are set correctly with regard to the unit itself.
5. Step the unit to a manual regeneration.
6. Verify that it functions correctly.
7. If the error reoccurs, unplug the unit.
8. Put it into bypass.
9. Contact dealer.



10.1.3 Regeneration failure

Info



The system has not regenerated for more than 99 days or 7 days if the controller type has been set to day of week.

1. Perform a manual regeneration to reset the error code.
2. If the system is metered, verify that it is measuring flow by running service water and watching for the flow indicator on the display.
3. If the unit doesn't measure flow, verify that the meter is working properly and its cable is well connected.
4. Enter master programming mode.
5. Verify that the unit is configured properly.
6. Check that system capacity has been selected.
7. Check that day override is set properly.
8. Check that meter is identified correctly.
9. If the unit is configured as a day of week system, verify that at least one day is set ON.
10. Correct the setting as necessary.



10.1.4 Memory error

Info



The controller board has a memory failure.

1. Perform a master reset.
2. Reconfigure the system via master programming mode.
3. Step the valve through a manual regeneration.
4. If the error reoccurs, unplug the unit.
5. Put it into bypass.
6. Contact dealer.



11 Spare parts and options

11.1 Valve parts list

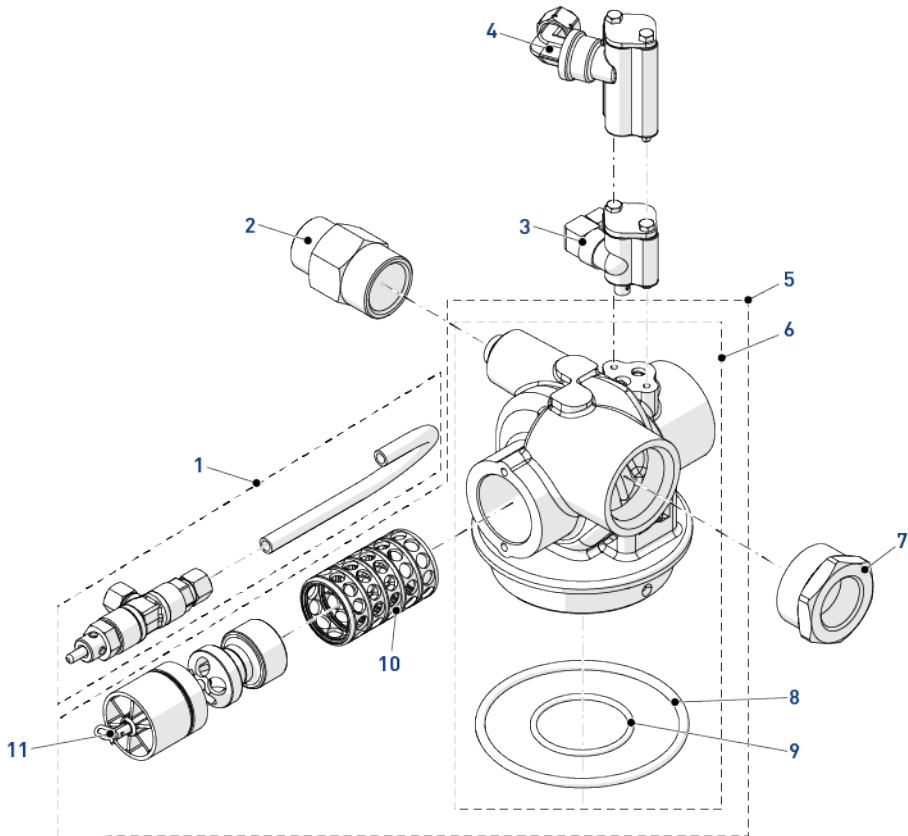

Item	Part number	Description	Packaging quantity
1	-	Brine valve (see Brine valve parts list [▶ Page 97])	-
2	25581-ALL	DLFC kit 1" 2850/9500 10, 12, 15, 20 and 25 gpm	1
3	-	1600/1650 injector assy (see 1600/1650 injector parts list [▶ Page 94])	1
4	-	1700/1710 injector assy (see 1700/1710 injector parts list [▶ Page 96])	1
5	BU28514-01	VB assy 2850	1
-	BU28514-02	VB assy 2850 NBP	1
6	BU28652	VB 2850 with o-rings	1
7	24991	Reducer nipple 1 1/2" to 1" female	1

Item	Part number	Description	Packaging quantity
8	16455-01	O-ring 560CD	1
9	13577-01SP	O-ring 560CD distributor tube	10
10	BU28684	S&S kit plastic 2850	1
-	29074	S&S kit 2850 HW	1
11	26494-00	Piston assy 2850 NBP	1
-	25155	Piston assy 2850	1

11.2 Power head parts list

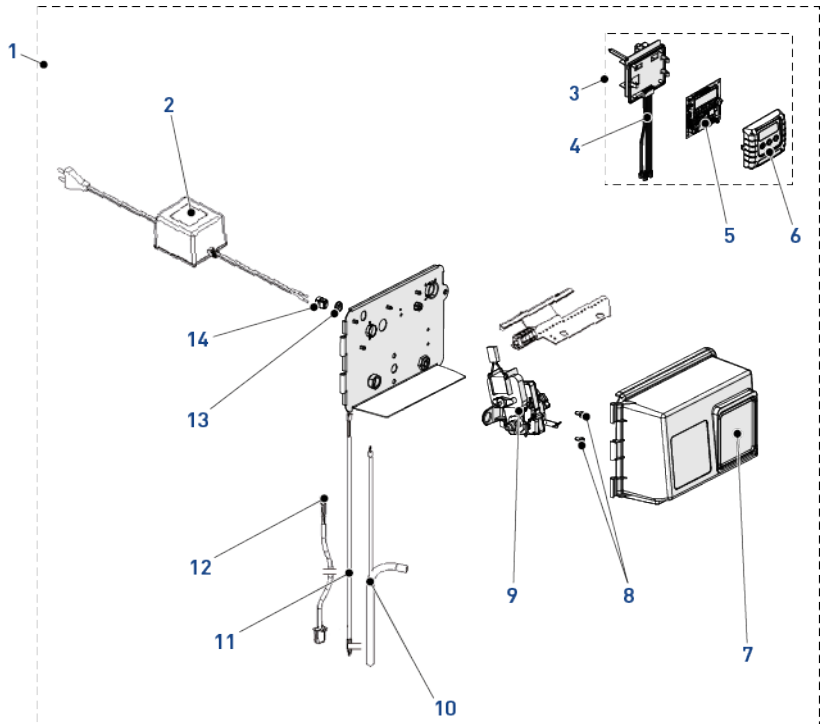

Item	Part number	Description	Packaging quantity
1	VCPHINDUS1	Power head 2510/2750/2850/2910	1
2	26260	Transformer 24 VAC, 60 VA	1
-	11545	Power cord European black	1
3	BU28712-01	Timer assy SXT 2510/2750/2850/2910	1
4	BU28600	Wire harness power SXT	1
5	BR43346-E0	Circuit board SXT programmed eco	1

Item	Part number	Description	Packaging quantity
6	BU28714	Cover front panel & label SXT	1
7	26217-01	Cover assy grey - clear window	1
8	10231SP	Screw hex head industrial	50
9	27204-01	Drive motor assy 2510/2750/2850 DF 24 V	1
10	25350	Guide cable & cable assy 2850 1"	1
-	27105	Guide cable & cable assy 2850 1½"	1
-	25351	Guide cable & cable assy 2850	1
11	BR19791-01	Turbine meter cable elec 0,450 m	1
12	19121-01	Meter cable SE/SXT 0,450 m	1
13	28704SP	Plug	10
14	13547SP	Strain relief 24 V	50

11.3 Injector parts list

11.3.1 1600/1650 injector parts list

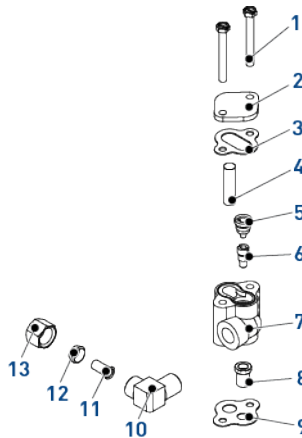

Item	Part number	Description	Packaging quantity
-	24199-000	Inj assy 1600 2750/2850/2900/2910	1
-	24199-00	Inj assy 1600 2750/2850/2900/2910	1
-	24199-0	Inj assy 1600 2750/2850/2900/2910	1
-	24199-1	Inj assy 1600 2750/2850/2900/2910	1
-	24199-2	Inj assy 1600 2750/2850/2900/2910	1
-	24199-3	Inj assy 1600 2750/2850/2900/2910	1
-	24555-0	Inj assy 1600 HW	1
-	24555-1	Inj assy 1600 HW	1

Item	Part number	Description	Packaging quantity
-	24555-2	Inj assy 1600 HW	1
-	24555-3	Inj assy 1600 HW	1
1	23476	Screw	1
2	11893SP	Inj cover	10
3	10229SP	Inj cover gasket	10
4	10227SP	Inj screen	10
5	10913-000SP	Inj nozzle #000	10
-	10913-00SP	Inj nozzle #00	10
-	10913-0SP	Inj nozzle #0	10
-	10913-1SP	Inj nozzle #1	10
-	10913-2SP	Inj nozzle #2	10
-	10913-3SP	Inj nozzle #3	10
6	10914-000SP	Inj throat #000	10
-	10914-00SP	Inj throat #00	10
-	10914-0SP	Inj throat #0	10
-	10914-1SP	Inj throat #1	10
-	10914-2SP	Inj throat #2	10
-	10914-3SP	Inj throat #3	10
7	17776	Inj body	1
8	16221	Air disperser	10
9	23304SP	Inj body gasket	10
10	10328	Male elbow	1
11	10332SP	Insert sleeve 3/8"	50
12	10330SP	Delrin sleeve 3/8"	50
13	10329SP	Fitting nut 3/8"	10

11.3.2 1700/1710 injector parts list

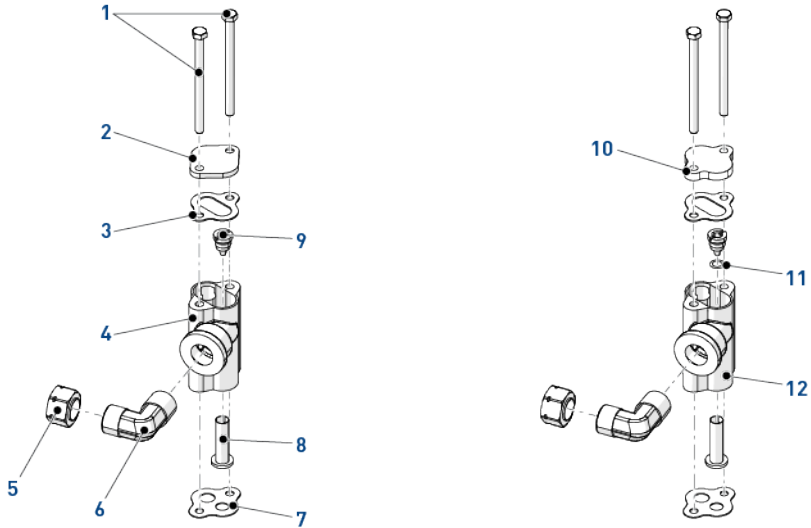

Item	Part number	Description	Packaging quantity
-	24173-3	Inj assy 1700/1710	1
-	24173-4	Inj assy 1700/1710	1
-	24173-5	Inj assy 1700/1710	1
1	23477SP	Screw	50
2	11893SP	Inj flat cover	10
3	10229SP	Inj cover gasket	10
4	17777-03	Inj body 3C-5C	1
5	15414	Nut & sleeve assy 1/2"	1
6	15413	Elbow fitting male 1.2 t x 3/8" NPT	1
7	23304SP	Inj body gasket	10
8	14802-03CSP	Inj throat 3C	10
-	14802-04CSP	Inj throat 4C	10
-	14802-05CSP	Inj throat 5C	10
-	14802-06CSP	Inj throat 6C	10
-	14802-07CSP	Inj throat 7C	10
9	14801-03CSP	Inj nozzle 3C	10
-	14801-04CSP	Inj nozzle 4C	10
-	14801-05CSP	Inj nozzle 5C	10
-	14801-06CSP	Inj nozzle 6C	10
-	14801-07CSP	Inj nozzle 7C	10

Item	Part number	Description	Packaging quantity
10	10228SP	Inj cover	10
11	13771SP	O-ring	50
12	17777-03	Inj body 6C-7C	1

11.4 Brine valve parts list

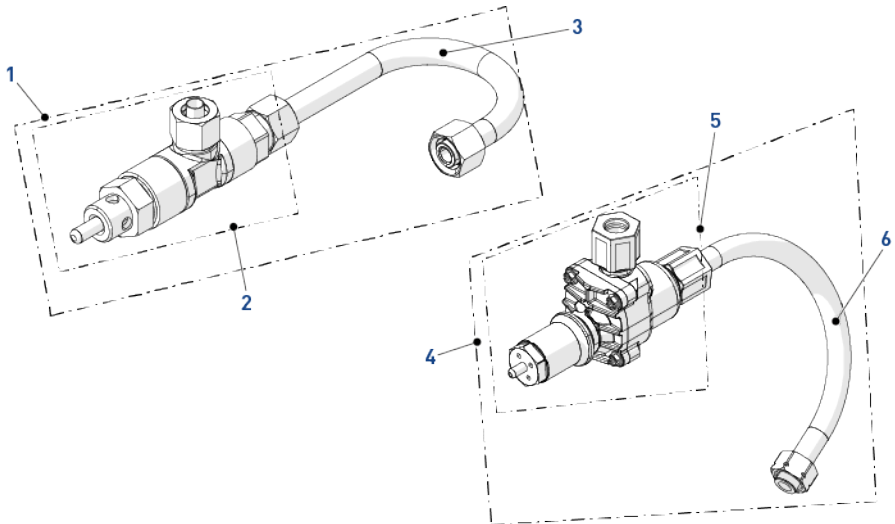

Item	Part number	Description	Packaging quantity
1	26909-0.25	BV 1600 assy 2750NBP/2850 0.25 gpm	1
-	26909-0.50	BV 1600 assy 2750NBP/2850 0.50 gpm	1
-	26909-1	BV 1600 assy 2750NBP/2850 1 gpm	1
-	BU28796-0.25	BV 1650 assy 2850 NBP 0.25 gpm	1
-	BU28796-0.50	BV 1650 assy 2850 NBP 0.50 gpm	1
-	BU28796-1	BV 1650 assy 2850 NBP 1 gpm	1
-	BU28797-0.25	BV 1650 assy 2750NBP/2850/2910 0.25 gpm	1
-	BU28797-0.50	BV 1650 assy 2750NBP/2850/2910 0.50 gpm	1
-	BU28797-1	BV 1650 assy 2750NBP/2850/2910 1 gpm	1
2	18092-0.25	Kit BV 1600 & BLFC assy indus 0.25 gpm	1
-	18092-0.50	Kit BV 1600 & BLFC assy indus 0.50 gpm	1
-	18092-1	Kit BV 1600 & BLFC assy indus 1 gpm	1
-	26677-0.25	Kit BV 1650 assy 0.25 gpm	1
-	26677-0.50	Kit BV 1650 assy 0.50 gpm	1
-	26677-1	Kit BV 1650 assy 1 gpm	1

Item	Part number	Description	Packaging quantity
3	19337	Brine tube 1600 2850 NBP plastic	1
-	16508-01	Brine tube 1600/1650 2850 WBP	1
4	26991-1.2	BV 1700 assy 2750 NBP/2850 WBP/2910 1.20 gpm	1
-	26991-2.0	BV 1700 assy 2750 NBP/2850 WBP/2910 2.00 gpm	1
-	26991-4.0	BV 1700 assy 2750 NBP/2850 WBP/2910 4.00 gpm	1
-	26992-1.2	BV 1700 assy 2850 NBP 1.20 gpm	1
-	26992-2.0	BV 1700 assy 2850 NBP 2.00 gpm	1
-	26992-4.0	BV 1700 assy 2850 NBP 4.00 gpm	1
-	BU28608-1.2	BV 1710 2850 NBP 1.20 gpm	1
-	BU28608-2	BV 1710 2850 NBP 2.00 gpm	1
-	BU28608-4	BV 1710 2850 NBP 4.00 gpm	1
-	BU28608-7	BV 1710 2850 NBP 7.00 gpm	1
-	BU28610-1.2	BV 1710 2750 NBP/2850 WBP/2910 1.20gpm	1
-	BU28610-2	BV 1710 2750 NBP/2850 WBP/2910 2.00 gpm	1
-	BU28610-4	BV 1710 2750 NBP/2850 WBP/2910 4.00 gpm	1
-	BU28610-7	BV 1710 2750 NBP/2850 WBP/2910 7.00 gpm	1
5	24181-1.2	Kit BV 1700 assy 1.20 gpm	1
-	24181-2	Kit BV 1700 assy 2.00 gpm	1
-	24181-4	Kit BV 1700 assy 4.00 gpm	1
-	24181-7	Kit BV 1700 assy 7.00 gpm	1
-	28423-1.2	BV 1710 1.2 gpm except 9500	1
-	28423-2	BV 1710 2 gpm except 9500	1
-	28423-4	BV 1710 4 gpm except 9500	1
-	28423-7	BV 1710 7 gpm except 9500	1
6	BR16460	Brine tube 1710 2850 WBP plastic	1
-	BU28493	Brine tube 1700 2850 WBP HW copper	1
-	19338	Brine tube 1710 2850 NBP plastic	1
-	BR19338	Brine tube 1700 2850 NBP HW copper	1

11.5 Safety brine valves list

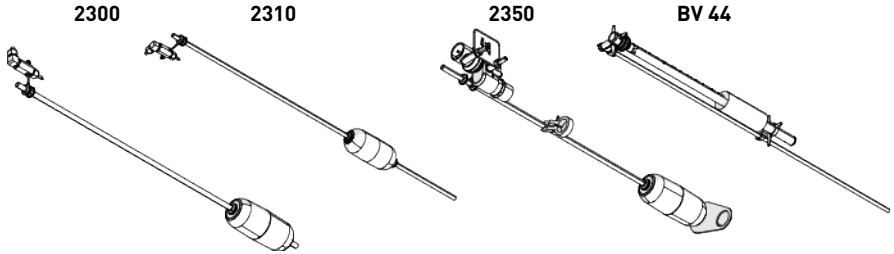

Item	Brine system	Part number	Description	Packaging quantity
-	1600	27833	Safety brine valve 2300, without air check	24
-		27834	Safety brine valve 2300, HW, without air check	24
-		60067-03	Safety brine valve 2310, without air check	24
-		25687	Brine valve 44, 914mm	10
-		18961	Brine valve 44, 1250mm	10
-	1710	25453	Safety brine valve 2350, without air check	5
-		25364	Mounting part 1" NPT male x 3/8" female	5

11.6 Safety brine valves parts list

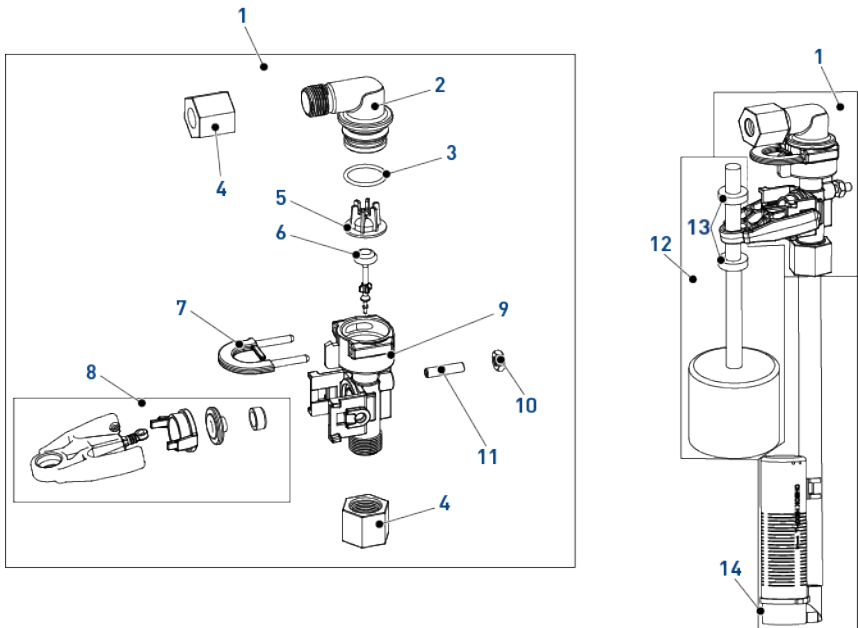

Item	Part number	Description	Packaging quantity
1	60014SP	Safety brine assy, 2310	10
2	26746	Elbow assy, safety brine valve	1
3	11183-01SP	O-ring	50
4	19625SP	Brine Valve 1650 plastic nut assy	10
5	19649	Flow disperser	1
6	PWG19652-01	Poppet assy, SBV, with o-ring	1
7	18312SP	Retainer, drain	10
8	PWG19803	Safety brine valve arm assy	1
9	19645	Body, safety brine valve, 2310	1
10	19805SP	Plastic SBV 2310 Nut	50
11	19804	Screw, sckt Hd, set, 10-24 x 0.75"	1
12	60068-30SP	New Float assy 2310	10
13	10150SP	Grommet pass rod 2300/2310/2350	50
14	18168	Air Check 500 (0,915 m)	48
-	26773	Air Check 500 (1,25 m)	48
-	23473	Air Check 500 (0,915 m) HW	48

11.7 Distribution systems parts list

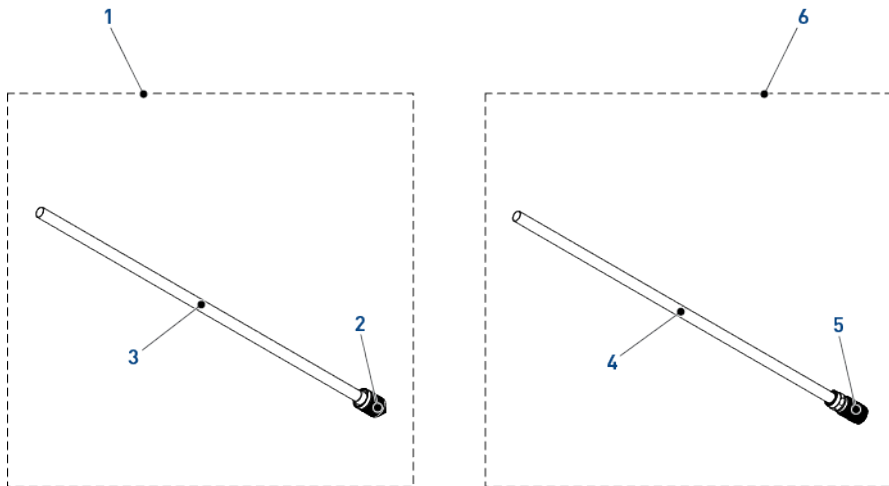

Item	Part number	Description	Packaging quantity
1	18404	2" assy, 1m82	5
2	18396	2" distributor	5
3	BU28649	2" tube, 1m66	5

Item	Part number	Description	Packaging quantity
4	21148HW	2" tube HW, 1m66	5
5	26050	2" distributor HW	5
6	BU26052	2" assy HW, 1m82	5

11.8 Air checks list

500

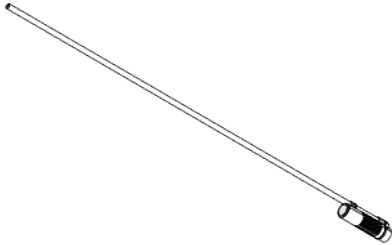

900

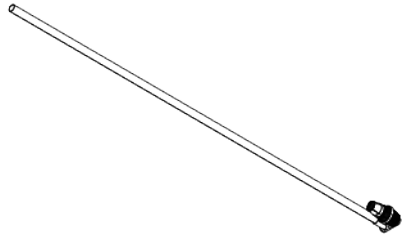

Item	Brine system	Part number	Description	Packaging quantity
-	1600	18168	Air checks 500A, 915mm [36"]	48
-		26773	Air checks 500A, 1m25	48
-		23473	Air checks 500 HW	48
-	1710	18979	Air checks 900, 1m88	5
-		BU28510	Air checks 900, 1m10	5
		18980	Air check 900 HW	5

11.9 Meters parts list

11.9.1 Brass meters parts list

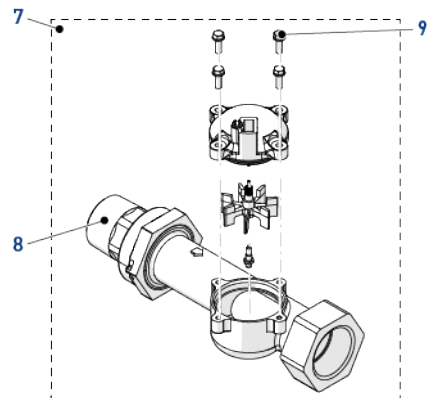
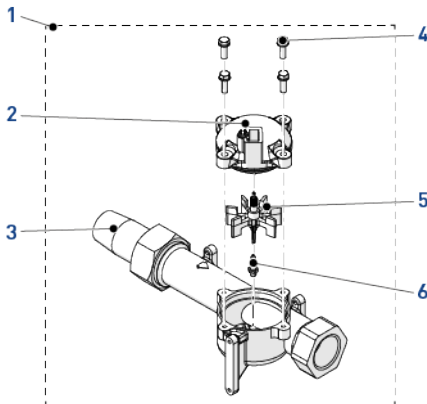

Item	Part number	Description	Packaging quantity
1	18391	Meter assy 1", elec	1
2	18330	Meter cover assy elec	1
3	14959-20	Meter body 1", indus	1
4	11737SP	Screw TH M5x12	50
5	13509SP	Impeller meter except 2" & 3"	10
6	13882SP	Impeller post for 13509	10
7	28076	Meter assy 1 1/2", elec	1
8	27957	Meter body 1 1/2"	1
9	12473SP	Screw Hex Washer 10-24x. 18-8SS	50

11.9.2 Stainless steel meters parts list

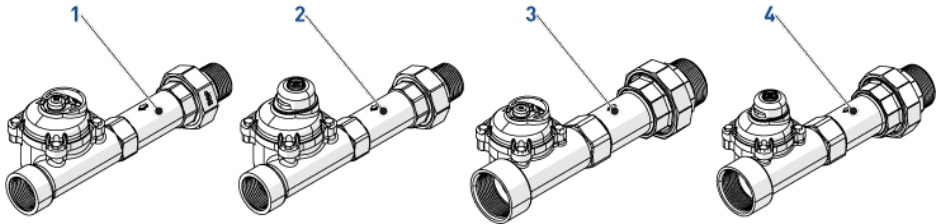

Item	Part number	Description	Packaging quantity
1	29089	Meter assy SS 1" BSP Mechanical 20 m³/Electronic	1
2	29090	Meter assy SS 1" BSP Mechanical 100 m³	1
3	29091	Meter assy SS 1.5" BSP Mechanical 40 m³/Electronic	1
4	29092	Meter assy SS 1.5" BSP Mechanical 200 m³	1

11.10 Kit meter & Meter cables list

11.10.1 Brass kit meter & Meter cables list

Item	Part number	Description	Packaging quantity
-	28283	Kit meter assy 1" NT /	1
-	28284	Kit meter assy 1.5" NT /	1
-	28285	Kit meter assy 2" NT /	1
-	28295	Kit meter assy 2" NT /	1
-	28286	Kit meter assy 3" NT /	1
-	28461-04	In-line meter 1 1/4" BSP plastic	1
-	19121-08	Meter cable SE/SXT 0.75 m	1
-	19121-09	Meter cable NT / 2.5 m	1

Item	Part number	Description	Packaging quantity
-	19121-10	Meter cable NT / 7.7 m	1

11.10.2 Stainless steel kit meter & Meter cables list

Item	Part number	Description	Packaging quantity
-	29096	Kit meter assy 1" stainless	1
-	29097	Kit meter assy 1.5" stainless	1
-	29098	Kit meter assy 2" stainless	1
-	29082	Kit meter assy 3" stainless	1
-	BR19791-02	Meter cable electronic 0.75 m	1
-	BR19791-04	Meter cable electronic 2.5 m	1
-	BR19791-05	Meter cable electronic 7.7 m	1

11.11 CE compliance parts list

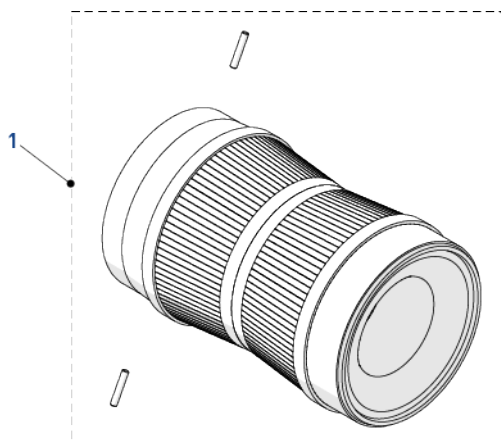

Item	Part number	Description	Packaging quantity
1	Kit 8	Top distributor 2" & pin assy	1
-	Kit 9	Top distributor 2" & pin assy HW	1

11.12 Other components list

Mixing assembly

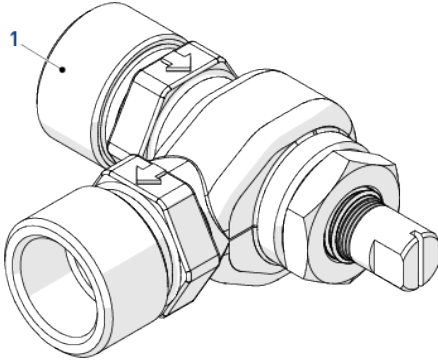

Rotating side mount adaptor

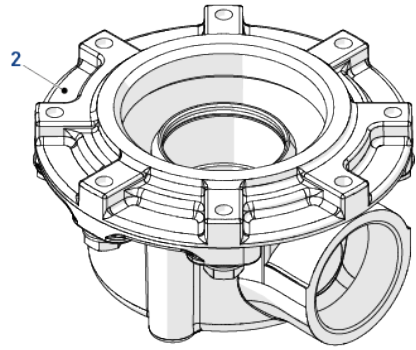

Item	Part number	Description	Packaging quantity
1	BU61564-10	Mixing assy 1" industrial	1
2	61415-20	Rotating side mount adaptor	1

12 Disposal

The device must be scrapped in accordance with directive 2012/19/EU or the environmental standards in force in the country of installation. The components included in the system must be separated and recycled in a waste recycling center that conforms with the legislation in force in the country of installation. This will help to reduce the impact on the environment, health, safety and help to promote recycling. Pentair do not collect used product for recycling. Contact your local recycling center for more information.





www.pentairaqueurope.com