



# **Water Specialist 2.0" NPT or BSPT**

## **No Hard Water Bypass**



Certified to NSF/ANSI 61 and 372\*

**Order No. V3098 • NPT**  
**Order No. V3098BSPT • BSPT**

- 2.0" NPT or 2.0" BSPT
- Durable 316 stainless steel casting
- Hydraulically balanced piston valve
- Allows for WS2.0 Valves to be used in multi-tank systems
- Full 2.0" ports with minimal pressure loss
- Provides for no raw water bypass during regeneration
- Provides choices of treated or non-treated water regeneration for WS2H
- Proven and reliable Clack DC drive assembly
- Low voltage drive assembly controlled by valve's circuit board
- Flow from male inlet to female outlet has a 2.6 PSI drop at 125 GPM
- Operating Pressures:  
20 PSI Minimum  
125 PSI Maximum
- Operating Temperatures:  
40°F Minimum  
110°F Maximum

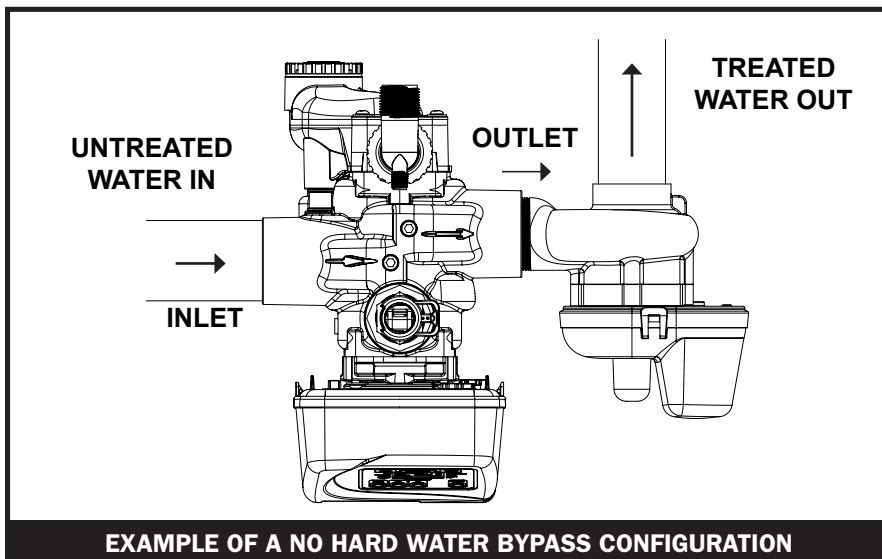

EXAMPLE OF A NO HARD WATER BYPASS CONFIGURATION

**Order No. V3098 • Description: NO HARDWATERBYPASS 2INMXF NPT or  
Order No. V3098BSPT • Description: NO HARDWATERBYPASS 2INMXF BSPT**

Drawing No.	Order No.	Description	Quantity	
			V3098	V3098BSPT
1	V3073	MAV/NOHWBY COVER ASY	1	1
2	V3476	WS MOTOR ASY 8 FT	1	1
3	V3592	SCREW #8-3/4 PHPN T-25 SS	3	3
4	V3262-01	WS1.5&2ALT/2BY REDUCGEARCVRAS	1	1
5	V3110-01	WS1 DRIVE REDUCING GEAR PLAIN	3	3
6	V3264	WS2 BYPASS REDUCTION GEAR AXLE	3	3
7	V3642	SCREW 1/4-20 X 1 1/4 BHSCS SS (5/32" HEX ALLEN WRENCH REQUIRED)	4	4
8	V3078	MAV/NOHWBY 2 DRIVE ASY	1	1
9	V3634-01	MAV/NOHWBY 2 PISTON	1	1
10	V3887	WS2 NHWBY STACK ASY	1	1
11	V3828-01	WS2 NHWBY BODY M X F NPT	1	N/A
	V3828BSPT-01	WS2 NHWBY BODY M X F BSPT	N/A	1
Not Shown	V3805	STRAIN RELIEF COVER KIT	1	1

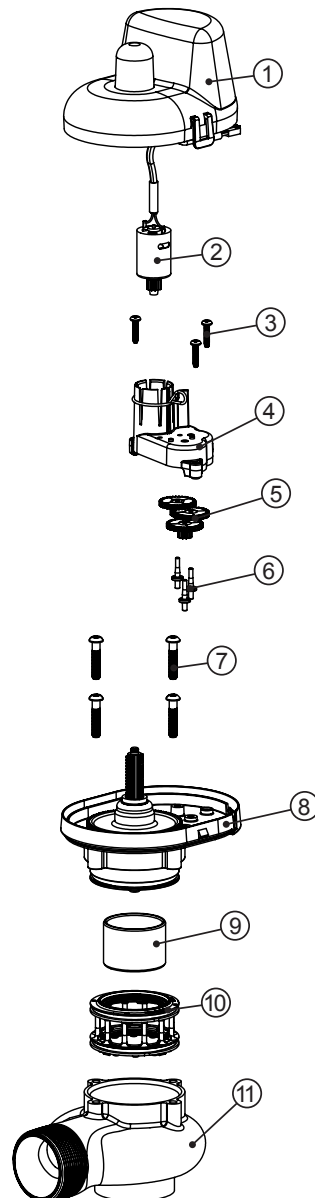

•Operating Pressures:  
20 PSI Minimum / 125 PSI Maximum  
•Operating Temperatures:  
40°F Minimum / 110°F Maximum

