



# **Water Specialist 3.0" NPT or BSPT**

## **No Hard Water Bypass**



**Order No. V3099 • NPT**  
**Order No. V3099BSPT • BSPT**

- 3" NPT and 3" BSPT
- Lead Free Brass Casting with NSF/FDA approved black coating
- Hydraulically balanced piston valve
- Allows for WS3 Valves to be used in multiple tank systems
- Full 3" ports with minimal pressure loss
- Provides for no raw water bypass during regeneration
- Provides choices of treated or non-treated water regeneration
- Proven and reliable Clack DC drive assembly
- Low voltage drive assembly controlled by valve's circuit board

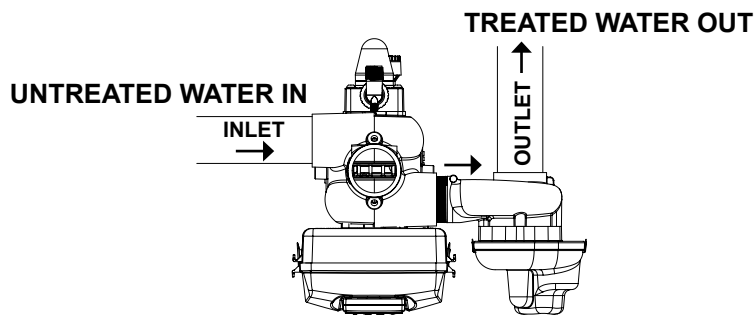

**EXAMPLE OF A NO HARD WATER BYPASS CONFIGURATION**

- Flow from the male inlet to the female outlet has a 1.9 PSI drop at 250 GPM
- Operating Pressures:  
20 PSI Minimum  
125 PSI Maximum
- Operating Temperatures:  
40°F Minimum  
110°F Maximum

**Order No. V3099 • Description: NO HARD WATER BYPASS 3INMXF NPT or  
Order No. V3099BSPT • Description: NO HARD WATER BYPASS 3INMXF BSPT**

Drawing No.	Order No.	Description	Quantity	
			V3099	V3099BSPT
1	V3696	WS3 MAV COVER	1	1
2	V3476	WS MOTOR ASY 8 FT	1	1
3	V3592	SCREW #8-3/4 PHPN T-25 SS	3	3
4	V3262-01	WS 1.5&2ALT/2BY REDUCGEARCVRASY	1	1
5	V3110	WS1 DRIVE REDUCING GEAR 12X36	3	3
6	V3264	WS2 BYPASS REDUCTION GEAR AXLE	3	3
7	V3789	SCREW 3/8-16 X 1.75 BHCS SS (7/32" hex allen wrench required)	4	4
8	V3085	WS3 MAV DRIVE CAP ASY	1	1
9	V3695-01	WS3 MAV PISTON	1	1
10	V3888	WS3 NHWBY STACK ASY	1	1
11	V3830-01	WS3 NHWBY M X F BODY NPT	1	N/A
	V3830BSPT-01	WS3 NHWBY M X F BODY BSPT	N/A	1

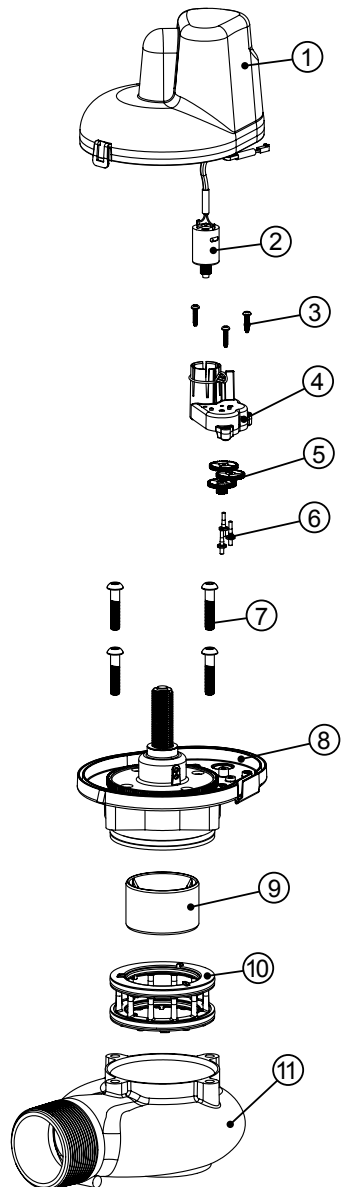

•Operating Pressures:  
20 PSI Minimum / 125 PSI Maximum  
•Operating Temperatures:  
40°F Minimum / 110°F Maximum

