

BNT89 Series Control Valve

1", DF&UF Electronic Control

Languages:



BNT89

Optional Model:



Specifications	
Valve Body Material	Noryl (PPO)
Plumbing Connectons	Straight 1" & 1.25" BSP&NPT
	Elbow 1" & 1.25" BSP&NPT
Tank Thread	2-1/2" NPSM
Adjustable Cycles	0 ~ 99 minutes
Regeneration	Up Flow / Down Flow
Regeneration Mode	Days, Calendar Weekday, Meter Immediate, Meter Delay, Meter Override
Meter Accuracy	±5%
Distributor Pilot	1.05", 1.32"
Drain Line	3/4" & 1" BSP&NPT
Brine Line	3/8" Quick Connect
Flow Rates (Valve Only 50 psi Inlet)	
Continuous (15 psi drop)	6200 L/H
Peak (25 psi drop)	8000 L/H
Max. Backwash (25 psi drop)	3900 L/H
Cv	7
Typical Applications	
Softeners	Up to 21" Diameter
Filters	Up to 18" Diameter
Electrical	
Input	Input 110V-120V / 220-240V AC 50/60 Hz
Output	12V AC 650mA
Operation Ratings	
Operating Pressure	0.14 – 0.84 Mpa
Water Temperature	1 – 42 °C
Approvals	
NSF44, CE, RoHS, ACS	
Additional Information	
Carton Size	320×235×290mm
Shipping Weight	3.2Kg

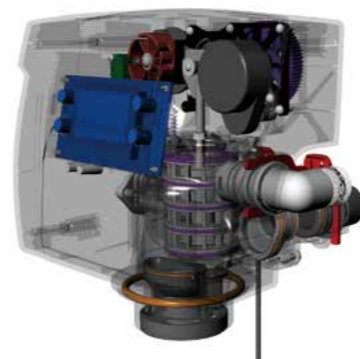

True 1" porting for high flow rates

- True 1" porting for high flow rates. Up to 21"softeners and 18" filters.
- Large 4 line Touch Pad LCD display – customizable for dealership.
- Soft Water Recharge performs quick regeneration ensuring you never run out of soft water.
- Time saving quick connect features on bypass, brine line, drain line and powercord.
- OD 1.32" distribution pipe is optional to install, service and backwash flow rate can be increased by 10%~15%.
- Integrated turbine meter.
- Comes with 1"&1.25" connections.

BNT95 Series Control Valve

1.25", DF Electronic Control

Languages:



BNT95

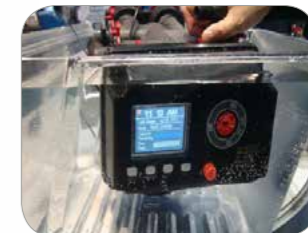

INNOVATIVE WATER PROOF

LARGE TFT COLOR DISPLAY

- User friendly large color display shows time of day, total remaining capacity, and flow indication
 - Water proof power head enclosure.
 - Up to 50.0 GPM flows (valve only) for commercial softening and filtration applications.
 - Time saving quick connects on all connections for easy installation including power cable.
 - Additional access ports with quick connect clips for easy sample points.
 - Calendar Clock, Meter Immediate, Meter Delayed and Meter/Day Override.
 - Fully adjustable cycle times.
 - Integrated turbine meter.
 - 48 hour self charging battery back-up keeps time-of-day stored while program settings are kept in permanent memory.
 - Simple to set program settings.
- Uses less power than an alarm clock (Less than \$2 annually).

Specifications	
Valve Body Material	Noryl (PPO)
Plumbing Connectons	Straight 1", 1.25", 1.5" BSP&NPT
Tank Thread	2-1/2" NPSM, 4"-8UN
Adjustable Cycles	Yes
Regeneration	Down Flow
Meter Accuracy	±5%
Distributor Pilot	1.05", 2"
Drain Line	3/4" & 1" BSP&NPT
Brine Line	1/2" BSP
Flow Rates (Valve Only 50 psi Inlet)	
Continuous (15 psi drop)	7000 L/H
Peak (25 psi drop)	9100 L/H
Max. Backwash (25 psi drop)	4100 L/H
Cv	8.0
Typical Applications	
Softeners	Up to 24" Diameter
Filters	Up to 21" Diameter
Electrical	
Input	Input 110V-120V / 220-240V AC 50/60 Hz
Output	12V AC 650mA
Operation Ratings	
Operating Pressure	0.14 – 0.84 Mpa
Water Temperature	1 – 42 °C
Approvals	
NSF44, CE, RoHS, ACS	
Additional Information	
Carton Size	385×285×280mm
Shipping Weight	3.2Kg